



ORIGINAL INSTRUCTIONS

Instruction Manual

4 Port Solenoid Valve Cassette Type Manifold

Series SJ1000/2000/3000

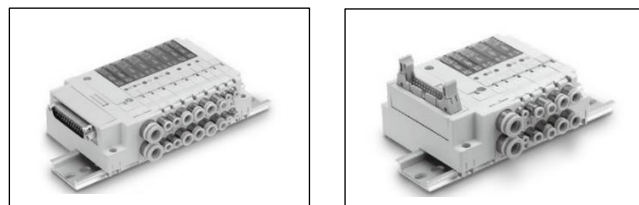

The intended use of this valve is to control the movement of an actuator.

1 Safety Instructions

These safety instructions are intended to prevent hazardous situations and/or equipment damage. These instructions indicate the level of potential hazard with the labels of "Caution," "Warning" or "Danger." They are all important notes for safety and must be followed in addition to International Standards (ISO/IEC) (1), and other safety regulations.

- ISO 4414: Pneumatic fluid power - General rules relating to systems.
- ISO 4413: Hydraulic fluid power - General rules relating to systems.
- IEC 60204-1: Safety of machinery - Electrical equipment of machines. (Part 1: General requirements)
- ISO 10218-1: Robots and robotic devices - Safety requirements for industrial robots - Part 1: Robots.

- Refer to product catalogue, Operation Manual and Handling Precautions for SMC Products for additional information.
- Keep this manual in a safe place for future reference.

	<b>Caution</b>	Caution indicates a hazard with a low level of risk which, if not avoided, could result in minor or moderate injury.
	<b>Warning</b>	Warning indicates a hazard with a medium level of risk which, if not avoided, could result in death or serious injury.
	<b>Danger</b>	Danger indicates a hazard with a high level of risk which, if not avoided, will result in death or serious injury.

**Warning**

- Always ensure compliance with relevant safety laws and standards.
- All work must be carried out in a safe manner by a qualified person in compliance with applicable national regulations.

2 Specifications

2.1 Valve specifications

Fluid	Air	
Internal pilot operating pressure range [MPa]	2 position single	0.15 to 0.7
	4 position dual 3 port	
	2 position double	
External pilot operating pressure range [MPa]	2 position single	0.25 to 0.7
	3 position	
Ambient and fluid temperature [°C]	-10 to 50 (no freezing)	
Response time	Refer to catalogue	
Flow rate	Refer to catalogue	
Minimum operating frequency	1 cycle / 30 days	
Maximum operating frequency [Hz]	2 position single / double	10
	4 position dual 3 port	
	3 position	
Manual override	SJ1000	Non-locking push type, Push-turn locking slotted type
	SJ2000 / 3000	Non-locking push type, Push-turn locking slotted type, Slide locking type
Pilot exhaust method	Internal pilot	Main and pilot valve common exhaust
	External pilot	Pilot valve individual exhaust

2 Specifications - continued

Mounting orientation	Unrestricted
Lubrication	Not required
Impact / Vibration resistance [m/s <sup>2</sup> Note 1)	150 / 30
Duty cycle	Contact SMC
Enclosure (based on IEC60529)	IP40
Weight (subject to configuration)	Refer to catalogue

Table 1.

Note 1) **Impact resistance:** No malfunction occurred when it was tested with a drop tester in the axial direction and at right angles to the main valve & armature in both energized & de-energized states and for every time in each condition. (Values quoted are for new valve).

**Vibration resistance:** No malfunction occurred in one-sweep test between 45 and 2000 Hz. Test was performed to axis and right angle directions of the main valve when pilot signal is ON and OFF. (Values quoted are for new valve).

2.2 Solenoid specifications

Coil rated voltage [VDC]	24, 12	
Allowable voltage fluctuation Note 1)	SJ1000	24 VDC -5% to +10%
	SJ2000 / SJ3000	12 VDC -6% to +10%
Coil insulation type	Equivalent to B type	
Power Consumption [W]	Standard	SJ2000 0.55
	With power saving circuit (Continuous duty type)	SJ3000 0.4
		SJ1000 / SJ2000 (Starting 0.23, Holding 0.23)
	SJ3000 (Starting 0.4, Holding 0.15)	0.15 Note 2)
Surge voltage suppressor	Diode	
Indicator Light	LED	

Table 2.

Note 1) Valve state is not defined if electrical input is outside of specified operating ranges.

Note 2) For the allowable voltage fluctuation for Z and T types (with power saving circuit), please observe the following range because they have the voltage drop due to internal circuit.

- Z type 24 VDC: -7% to +10%
- 12 VDC: -4% to +10%
- T type 24 VDC: -5% to +10%
- 12 VDC: -6% to +10%

2.3 Manifold specifications

Model	Connector type					
	D-sub	Flat ribbon cable		Serial wiring	Individual wiring	
	Type 60F	Type 60P	Type 60PG	Type 60PH	Type 60S#	Type 60S6B
Manifold type	SJ1000	Plug-in, connector type				-
	SJ2000	Plug-in, Connector type / cable type				Non plug-in
	SJ3000	Plug-in, Connector type				-
1 (P: SUP), 3/5 (E: EXH) type	Common SUP, EXH					
Valve stations (maximum)	Connector type: 1 to 24	1 to 18	1 to 8	1 to 32	1 to 16	1 to 20
	Cable type: 2 to 20					
Max. number of pins (points)	25	26	20	10	32	16
	4 / station					
4(A), 2(B) port piping spec.	Location					
	Valve					
	Horizontal					
	Horizontal, upward, downward (using elbow fittings for upward or downward)					
Port size	1(P), 3/5(E) port					
	C6, C8, N7, N9 (inch size elbow fitting is not available)					
	4(A), 2(B) port					
	C2, C4					
4(A), 2(B) port	C2, C4, N1, N3, M3					
	C2, C4, C6, N1, N3, N7, M5					
	-					

Table 3.

2.4 Pneumatic symbols

Refer to catalogue for pneumatic symbols.

2.5 Light indicator

**Caution**

When equipped with light/surge voltage suppressor, the light window turns orange when solenoid A is energized, and it turns green when solenoid B is energized.

2 Specifications - continued

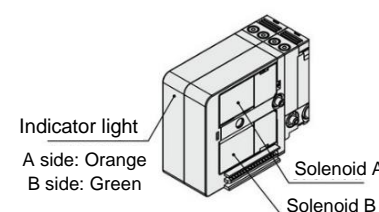

Figure 1.

**Warning**

Special products (-X) might have specifications different from those shown in this section. Contact SMC for specific drawings.

3 Installation

3.1 Installation

**Warning**

- Do not install the product unless the safety instructions have been read and understood.

3.2 Environment

**Warning**

- Do not use in an environment where corrosive gases, chemicals, saltwater or steam are present.
- Do not use in an explosive atmosphere.
- Do not expose to direct sunlight. Use a suitable protective cover.
- Do not install in a location subject to vibration or impact in excess of the product's specifications.
- Do not mount in a location exposed to radiant heat that would result in temperatures in excess of the product's specifications.
- If using in an atmosphere where there is possible contact with water droplets, oil, weld spatter, etc., take suitable preventive measures.
- Do not use in high humidity environment where condensation can occur.
- Contact SMC for altitude limitations.

3.3 Piping

**Caution**

- Before connecting piping make sure to clean up chips, cutting oil, dust etc.
- When installing piping or fittings, ensure sealant material does not enter inside the port. When using seal tape, leave 1 thread exposed on the end of the pipe/fitting.
- Tighten fittings to the specified tightening torque.

3.4 Lubrication

**Caution**

- SMC products have been lubricated for life at manufacture, and do not require lubrication in service.
- If a lubricant is used in the system, refer to catalogue for details.

3.5 Air supply

**Warning**

- Use clean air. If the compressed air supply includes chemicals, synthetic materials (including organic solvents), salinity, corrosive gas etc., it can lead to damage or malfunction.

**Caution**

- Install an air filter upstream of the valve. Select an air filter with a filtration size of 5 µm or smaller.

3.6 One-touch fittings

3.6.1 Tube attachment and detachment

**Caution**

Refer to the Specific Precautions in the catalogue.

3.6.2 Precautions on other tube brands

**Caution**

When using non-SMC brand tubes, refer to the Specific Precautions in the catalogue.

3 Installation - continued

3.7 Effect of back pressure when using a manifold

- Use caution when valves are used on a manifold, because an actuator may malfunction due to backpressure. In case the back pressure from other mounted valve cause the malfunction, use back pressure check valve option to prevent malfunction by using it.
- For 3-position exhaust centre valve or single acting cylinder, take appropriate measures to prevent malfunction by using it with a SUP/EXH block assembly and EXH block disc assembly.

3.8 Indicator light/surge voltage suppressor

3.8.1 Non-polar type

Single solenoid

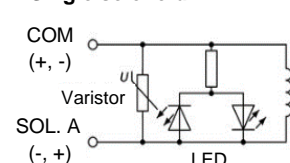

Double solenoid, 3 position type

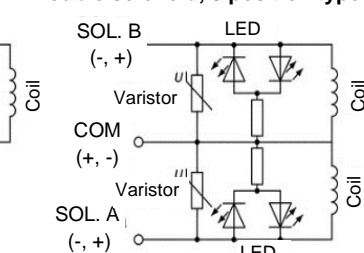
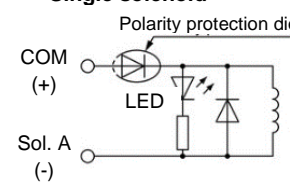

Figure 2.

3.8.2 Positive common

Single solenoid



Double solenoid, 3 position type

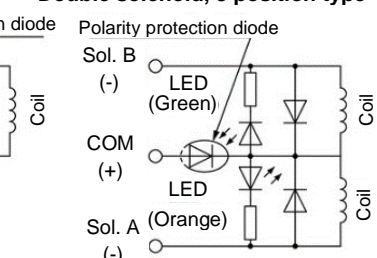
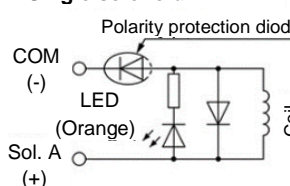

Figure 3.

3.8.3 Negative common

Single solenoid



Double solenoid, 3 position type

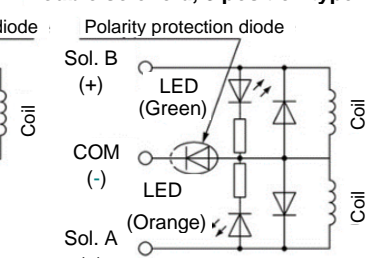

Figure 4.

3.9 With power saving circuit

Compared to the standard products, power consumption is reduced down to approx. 1/3 (in case of SJ3#60T) by cutting the unnecessary wattage required to hold the valve in an energized state. (Effective energizing time is over 67 ms at 24 VDC.)

In case of positive common, single solenoid

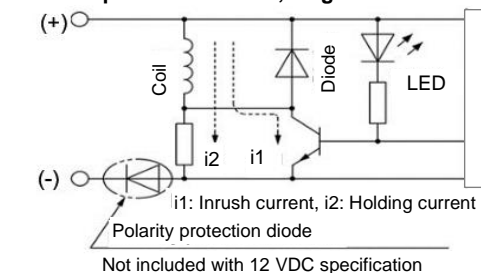

Figure 5.

### 3 Installation - continued

#### In case of negative common, single solenoid

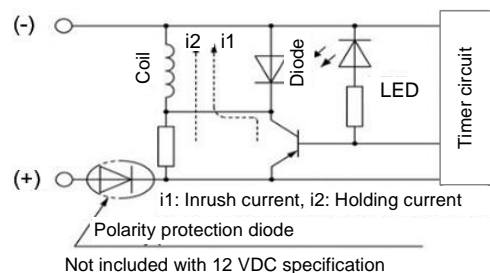
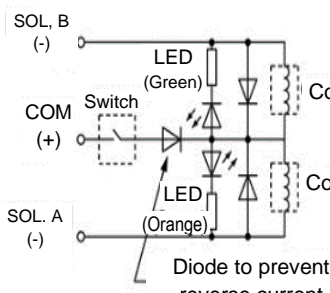

Figure 6.

#### 3.10 Valve with switch

##### Positive common spec.



##### Negative common spec.

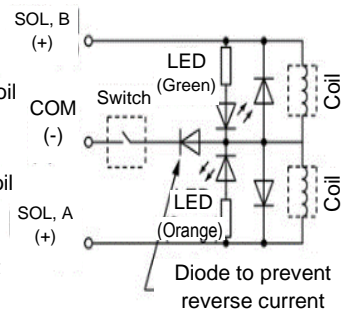

Figure 7.

#### 3.11 Residual voltage of the surge voltage suppressor

##### Caution

- If a surge protection circuit contains non-ordinary diodes such as Zener diodes or varistor, a residual voltage will remain that is in proportion to the protective elements and the rated voltage. Therefore, give consideration to surge voltage protection of the controller.
- In the case of diodes, the residual voltage is approximately 1 V.
- Contact SMC for the varistor's residual voltage.

#### 3.12 Countermeasure for surge voltage

##### Caution

- At times of sudden interruption of the power supply, the energy stored in a large inductive device may cause non-polar type valves in a de-energized state to switch.
- When installing a breaker circuit to isolate the power, consider a valve with polarity (with polarity protection diode), or install a surge absorption diode across the output of the breaker.

#### 3.13 Extended period of energization

##### Caution

- If a valve is energized continuously for a long time or is mounted in a control panel, the rise in temperature due to heat-up of the coil may cause a decline in solenoid valve performance, reduce service life, or have adverse effects on peripheral equipment.
- If a valve will be energized continuously, please be sure to use the "Continuous duty type" with a power saving circuit.
- There will be a large increase in temperature if 3 or more neighbouring stations are simultaneously continuously energized for a long time, or if the A and B sides are simultaneously continuously energized for a long time in a dual 3 port valve. Please be very careful in such cases.
- If the continuously energized time exceeds 30 minutes or the total energized time exceeds the total de-energized time in the day, please use with power saving circuit.

#### 3.14 Electrical wiring specifications

Refer catalogue for electrical wiring specifications.

#### 3.15 Manual override

##### Warning

Regardless of an electric signal for the valve, the manual override is used for switching the main valve. Since connected equipment will operate when the manual override is activated, confirm that conditions are safe prior to activation.

### 3 Installation - continued

##### Warning

Locked manual overrides might prevent the valve responding to being electrically de-energized or cause unexpected movement in the equipment. Refer to the catalogue for details of manual override operation.

#### 3.16 How to use plug connector

Refer to catalogue for additional details.

##### Caution

#### 3.16.1 Attaching and detaching connectors

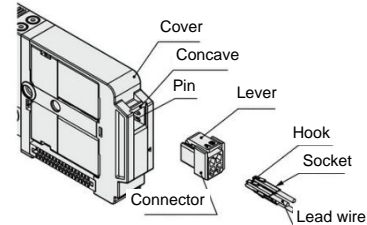

Figure 8.

#### 3.16.2 Crimping connection of a lead wire and socket

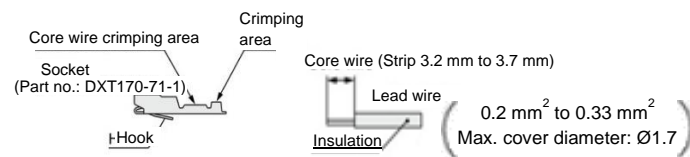

Figure 9.

#### 3.16.3 Attaching and detaching lead wires with socket

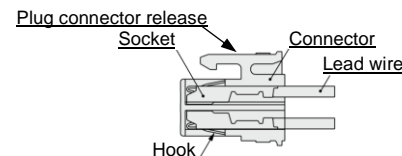

Figure 10.

#### 3.17 Use as a 3-port valve

##### Caution

The SJ1000/2000/3000 can be used as normally closed (N.C.) or normally open (N.O.) 3-port valves by closing one of the cylinder ports 4(A) or 2(B) with a plug. However, they should be used with the exhaust ports kept open. Refer to the catalogue for additional details.

#### 3.18 Exhaust restriction

##### Caution

Since the series SJ is a type in which the pilot valve exhaust joins the main valve exhaust inside the valve, care must be taken so that the piping from the exhaust port is not restricted.

#### 3.19 Back pressure check valve built-in type

##### Caution

- Valves with built-in back pressure check valve prevent back pressure inside the valve. For this reason, external pilot type is not allowed to be pressurised from exhaust port [3/5(E)]. Valves with integrated back pressure check valve have a reduced flow compared to those without check valve. For details, please contact SMC.
- Do not switch valves when 4(A) or 2(B) port is open to the atmosphere, or while the actuators and air operated equipment are in operation. The back pressure prevention seal may be damaged, which may cause air leakage or malfunctions. Use caution especially when performing a trial operation or maintenance work.

#### 3.20 Changing connector entry direction

##### Caution

Refer to the Specific Product Precautions in the catalogue.

### 4 How to Order

Refer to catalogue for 'How to order' or product drawing for special products.

### 5 Outline Dimensions (mm)

Refer to catalogue for outline dimensions.

### 6 Maintenance

#### 6.1 General maintenance

##### Caution

- Not following proper maintenance procedures could cause the product to malfunction and lead to equipment damage.
- If handled improperly, compressed air can be dangerous.
- Maintenance of pneumatic systems should be performed only by qualified personnel.
- Before performing maintenance, turn off the power supply and be sure to cut off the supply pressure. Confirm that the air is released to atmosphere.
- After installation and maintenance, apply operating pressure and power to the equipment and perform appropriate functional and leakage tests to make sure the equipment is installed correctly.
- If any electrical connections are disturbed during maintenance, ensure they are reconnected correctly, and safety checks are carried out as required to ensure continued compliance with applicable national regulations.
- Do not make any modification to the product.
- Do not disassemble the product, unless required by installation or maintenance instructions.
- When the 3-position closed centre type is in its rest position, air can be trapped between the valve and the cylinder. Exhaust this air pressure before removing piping or performing any maintenance.

#### 6.2 Fitting replacement

##### Caution

By replacing a valve's fitting assembly, it is possible to change the port size of the 4(A), 2(B), 1(P), and 3/5(E) ports. When replacing it, pull out the fitting assembly after removing the clip with a flat blade screwdriver, etc. To mount a new fitting assembly, insert it into place and then fully reinsert the clip.

##### Caution

Do not scratch or put foreign matter on the O-rings as this will cause air

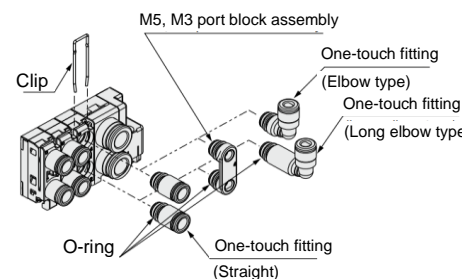

Figure 11.

leakage.

#### 6.3 Increase manifold stations

Refer to catalogue for details on how to increase connector type manifold stations.

##### Caution

Make sure the screws are tightened to the below recommended tightening torques;

Description	Screw type	Recommended tightening torque [N·m]
D-sub, Connector block assembly for flat ribbon cable, End block assembly	M3	0.6
Connector block assembly for EX180 serial wiring	M4	1.4
Mounting bracket for EX510 serial wiring	M4	0.6

Table 4.

### 7 Limitations of Use

##### Warning

The system designer should determine the effect of the possible failure modes of the product on the system.

#### 7.1 Limited warranty and disclaimer/compliance requirements

Refer to Handling Precautions for SMC Products.

#### 7.2 Leakage voltage

Ensure that any leakage voltage caused by the leakage current when the switching element is OFF is  $\leq 3\%$  or less of the rated voltage across the valve.

#### 7.3 Low temperature operation

Unless otherwise indicated in the specifications for each valve, operation is possible to  $-10^{\circ}\text{C}$ , but appropriate measures should be taken to avoid solidification or freezing of drainage and moisture, etc.

#### 7.4 Intermediate stopping

Refer to Handling Precautions for 3/4/5 port Solenoid Valves.

#### 7.5 Holding of pressure (including vacuum)

Since valves are subject to air leakage, they cannot be used for applications such as holding pressure (including vacuum) in a pressure vessel.

#### 7.6 Momentary energization/operation

##### Caution

If a double solenoid valve is operated with momentary energization, it should be energized for at least 0.1 second. However, depending on the secondary load conditions, it should be energized until the cylinder reaches the stroke end position, as there is a possibility of malfunction otherwise.

#### 7.7 Air returned or air/spring returned spool valves

##### Warning

The use of 2-position single valves with air returned spools must be carefully considered.

The return of the valve spool into the de-energized position depends on the pilot pressure. If the pilot pressure drops below the specified operating pressure the position of the spool cannot be defined.

The design of the system must consider such behaviour.

Additional measures might be necessary. For example, the installation of an additional air tank to maintain the pilot pressure.

Energy source status	Single	Double	3 position	Dual 3 port
Air supply present, electricity cut	Spool returns to the off position by air force	Spool stops moving after electricity cut (Position cannot be defined)	Spool returns to the off position by spring force	Spools return to the off position by air force
Air supply cut before electricity cut	Spool stops moving after air pressure cut (Position cannot be defined)	Spool stops moving after air pressure cut (Position cannot be defined)		Spool stops moving after air pressure cut (Position cannot be defined)

Table 5.

#### 7.8 Safety relays or PLC

##### Warning

If a safe output from a safety relay or PLC is used to operate this valve, ensure that any output test pulse duration is shorter than 1 ms to avoid the valve solenoid responding.

### 8 Product Disposal

This product shall not be disposed of as municipal waste. Check your local regulations and guidelines to dispose this product correctly, in order to reduce the impact on human health and the environment.

### 9 Contacts

Refer to [www.smcworld.com](http://www.smcworld.com) or [www.smc.eu](http://www.smc.eu) for your local distributor/importer.

## SMC Corporation

URL : <https://www.smcworld.com> (Global) <https://www.smc.eu> (Europe)  
 SMC Corporation, 4-14-1, Sotokanda, Chiyoda-ku, Tokyo 101-0021, Japan  
 Specifications are subject to change without prior notice from the manufacturer.  
 © 2021 SMC Corporation All Rights Reserved.  
 Template DKP50047-F-085M