

Made to Order Common Specifications: -XB20: Stroke Adjustment Unit with Adjustment Bolt



12 Stroke Adjustment Unit with Adjustment Bolt

Stroke adjustment unit with an adjustment bolt.

Applicable Series

Series	Description	Model	Action	Vol. no. (for std model)
MY2	Mechanically jointed rodless cylinder	MY2H	Linear guide (Single axis)	①-1 From P. 1388
		MY2HT	Linear guide (Double axis)	

How to Order

MY2H
MY2HT Standard model no. -XB20

Stroke Adjustment Unit Specifications

Bore size (mm)		16		25		40	
Unit symbol		L	H	L	H	L	H
Shock absorber model	MY2H	RB0806	RB1007	RB1007	RB1412	RB1412	RB2015
	MY2HT	RB1007	RB1412	RB1412	RB2015	RB2015	RB2725
Stroke adjustment range by intermediate fixing spacer (mm)	Without spacer	0 to -5.6		0 to -11.5		0 to -16	
	With short spacer	-5.6 to -11.2		-11.5 to -23		-16 to -32	
	With long spacer	-11.2 to -16.8		-23 to -34.5		-32 to -48	

* Spacers are used to fix the stroke adjustment unit at an intermediate stroke position.
* Stroke adjustment range is applicable for one side when mounted on a cylinder.

Stroke adjustment unit mounting diagram

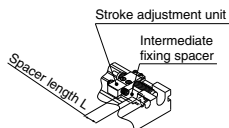

Example of L6L7 attachment

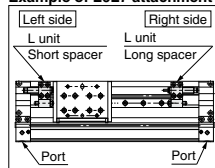

Stroke Adjustment Unit Model

Note) Stroke adjustment unit with adjusting bolt (-XB20) cannot be mounted on the standard cylinder.

Guide symbol • **MY2** H - **A** 25 L2 - **6N** - **XB20**

Symbol	Stroke adjustment unit
H	MY2H16
H	MY2H25
H	MY2H40
HT	MY2HT16
HT	MY2HT25
HT	MY2HT40

Stroke adjustment unit

Symbol	Cylinder bore size
16	16 mm
25	25 mm
40	40 mm

Unit part no. •

Symbol	Stroke adjustment unit	Mounting position
L1	L unit	For left
L2		For right
H1	H unit	For left
H2		For right

With adjustment bolt

Intermediate fixing spacer

Nil	Without spacer
6	Short spacer
7	Long spacer

Spacer shipping method

Nil	Assembled as a unit
N	Spacer only

* Spacers for MY2HT are shipped in 2 piece sets.

* Intermediate fixing spacers are shipped together.

MY2H (-XB20)

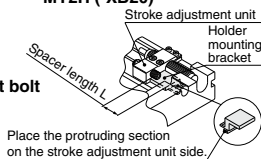

MY2HT (-XB20)

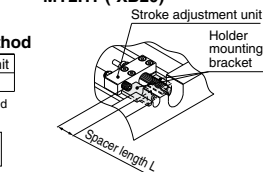

Components Parts

MY2H-A25L2-XB20 (Without spacer)

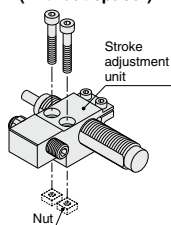

MY2H-A25L2-6-XB20 (With short spacer)

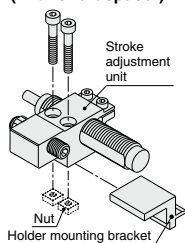

MY2H-A25L2-7-XB20 (With long spacer)

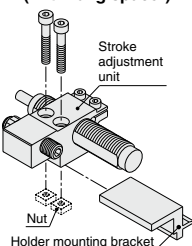

MY2H-A25L2-6N-XB20 (Short spacer only)

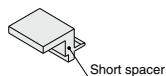

MY2H-A25L2-7N-XB20 (Long spacer only)

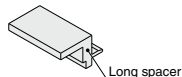

* Nuts are installed onto the cylinder body.

Made to Order Common Specifications: Stroke Adjustment Unit with Adjustment Bolt

Symbol
-XB20

Dimensions (Dimensions other than below are the same as standard type.)

MY2H L unit

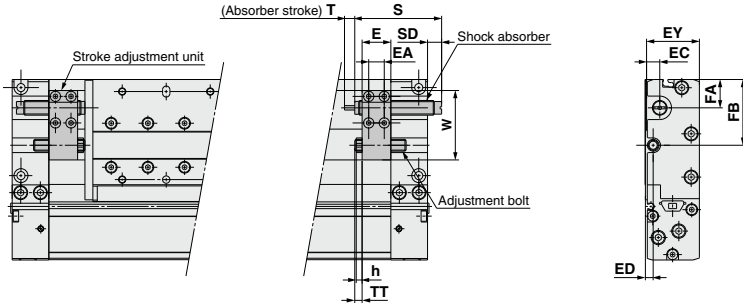

Applicable cylinder	E	EA	EC	ED	EY	FA	FB	h	S	T	SD	TT	W	Shock absorber model	Adjusting bolt	Adjustment range
MY2H16	15.8	8.4	6.2	5	28	12.4	30	3.2	40.8	6	1.3	4.2 (Max. 9.8)	34.5	RB0806	M5 x 0.8 x 25L	5.6
MY2H25	19.6	10.6	10	5.5	37	19.3	44.8	4	46.7	7	—	5 (Max. 16.5)	47.3	RB1007	M8 x 1.0 x 35L	11.5
MY2H40	29	16	13	8	57	17	49	5	67.3	12	—	6 (Max. 22)	59	RB1412	M10 x 1.0 x 50L	16

MY2H H unit

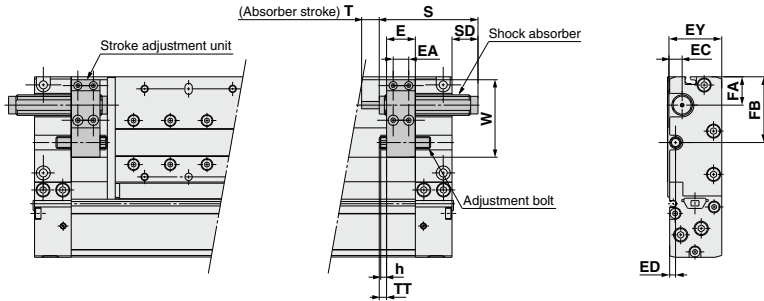

Applicable cylinder	E	EA	EC	ED	EY	FA	FB	h	S	SD	T	TT	W	Shock absorber model	Adjustment bolt	Adjustment range
MY2H16	15.8	8.4	6.2	5	28	12.4	30	3.2	46.7	7.2	7	4.2 (Max. 9.8)	35.5	RB1007	M5 x 0.8 x 25L	5.6
MY2H25	19.6	10.6	10	5.5	37	19.3	44.8	4	67.3	18.2	12	5 (Max. 16.5)	52.8	RB1412	M8 x 1.0 x 35L	11.5
MY2H40	29	16	13	8	57	17	49	5	73.2	—	15	6 (Max. 22)	59	RB2015	M10 x 1.0 x 50L	16

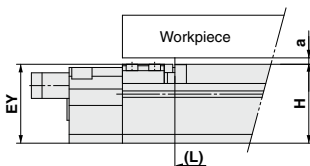

⚠ Caution

Since the dimension **EY** of the unit is greater than the table top height (dimension **H**), when a workpiece is loaded that is larger than the full length (dimension **L**) of the slide table, allow a clearance of size "a" or larger at the workpiece side.

Applicable cylinder	a	EY	H
MY2H16 L/H Unit	1	28	28
MY2H25 L/H Unit	1	37	37
MY2H40 L/H Unit	0	57	58

Made to Order Common Specifications: -XB20: Stroke Adjustment Unit with Adjustment Bolt



12 Stroke Adjustment Unit with Adjustment Bolt

Dimensions (Dimensions other than below are the same as standard type.)

MY2HT L unit

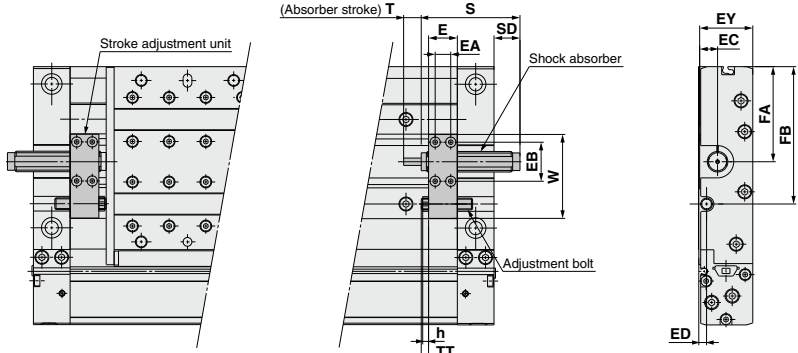

Applicable cylinder	E	EA	EB	EC	ED	EY	FA	FB	h	S	SD	T	TT	W	Shock absorber model	Adjustment bolt	Adjustment range
MY2HT16	15.8	8.4	21	9	5	28	46.5	67	3.2	46.7	7.2	7	4.2 (Max. 9.8)	40.6	RB1007	M5 x 0.8 x 25L	5.6
MY2HT25	19.6	10.6	26.6	12.2	5.5	37	64.8	93.6	4	67.3	18.2	12	5 (Max. 16.5)	57.2	RB1412	M8 x 1.0 x 35L	11.5
MY2HT40	29	16	37	18.2	8	58	74.5	110.5	5	73.2	—	15	6 (Max. 22)	71.6	RB2015	M10 x 1.0 x 50L	16

MY2HT H unit

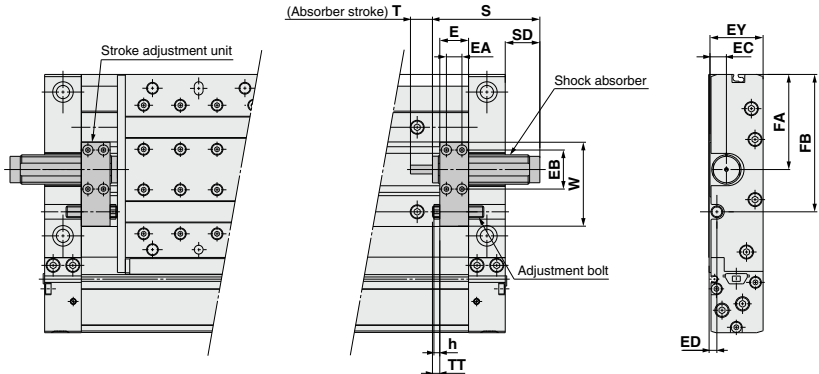

Applicable cylinder	E	EA	EB	EC	ED	EY	FA	FB	h	S	SD	T	TT	W	Shock absorber model	Adjustment bolt	Adjustment range
MY2HT16	15.8	8.4	21	9	5	28	46.5	67	3.2	67.3	27.8	12	4.2 (Max. 9.8)	40.6	RB1412	M5 x 0.8 x 25L	5.6
MY2HT25	19.6	10.6	26.6	12.2	5.5	37	64.8	93.6	4	73.2	24.1	15	5 (Max. 16.5)	57.2	RB2015	M8 x 1.0 x 35L	11.5
MY2HT40	29	16	37	18.2	8	58	74.5	110.5	5	99	24.5	25	6 (Max. 22)	71.6	RB2725	M10 x 1.0 x 50L	16

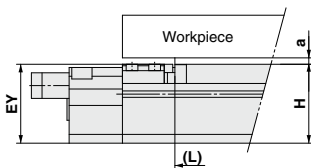

⚠ Caution

Since the dimension EY of the unit is greater than the table top height (dimension H), when a workpiece is loaded that is larger than the full length (dimension L) of the slide table, allow a clearance of size "a" or larger at the workpiece side.

Applicable cylinder	a	EY	H
MY2HT16 L/H Unit	1	28	28
MY2HT25 L/H Unit	1	37	37
MY2HT40 L/H Unit	1	58	58

XB20 (Stroke Adjustment Unit with Adjustment Bolt)

⚠ Caution

<Stroke adjustment with adjusting bolt>

1. Loosen the lock nut for the adjustment bolt and adjust a stroke by rotating the adjustment bolt.

After adjusting the stroke, secure the adjustment bolt by tightening the lock nut.

If the effective stroke of the shock absorber is shortened by the stroke adjustment, its absorption capacity will be drastically reduced. Therefore, the adjustment bolt should be secured at a position where it projects about 0.5 mm farther than the shock absorber.

Tighten shock absorber holding bolts equally with the specified tightening torque.

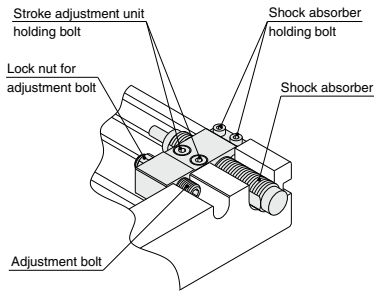

MY2H(-XB20)

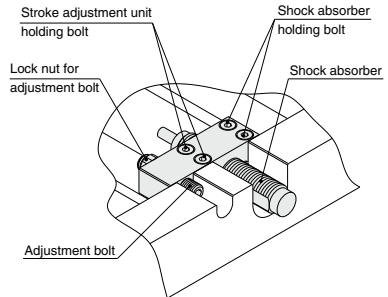

MY2HT(-XB20)

Tightening Torque for Stroke Adjustment Unit Holding Bolt

(N·m)

Bore size (mm)	MY2H		MY2HT	
	L unit	H unit	L unit	H unit
16		0.6		
25		1.5		
40		5.0		

Tightening Torque for Shock Absorber Holding Bolt

(N·m)

Bore size (mm)	MY2H		MY2HT	
	L unit	H unit	L unit	H unit
16		0.6		
25	1.5	0.6		1.5
40	5.0	1.5		5.0

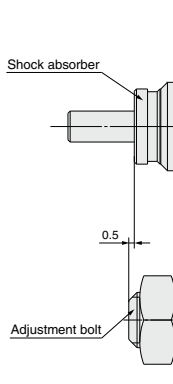

2. Do not use the shock absorber and air cushion together.

