

5 Port Solenoid Valve

SQ1000/2000 Series

Metal Seal

Rubber Seal

The connection cable and various units for PLC connection in PC wiring systems have been discontinued by the manufacturer. Therefore, while they can no longer be provided, the valve manifold (manifold with built-in valves) can still be ordered. For details, refer to the [Web Catalog](#).



Power Saving

Standard **0.4w**
Compared to current model **60% DOWN** ↓

High pressure **0.95w**
(1 MPa Metal seal)

Easy Replacement of Clip Type One-touch Fittings

One-touch fittings can be replaced without removing valves.

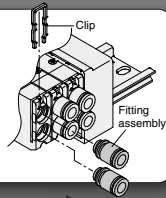

Connector Entry Direction Can be Changed with a Single Push.

The connector entry direction can be changed from the top to the side by simply pressing the manual release button. It is not necessary to use the manual release button when switching from the side to the top.

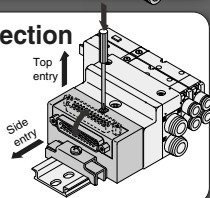

4 Position Dual 3 Port Valve

- Two 3-port valves built into one body.
- The 3-port valves on the A and B sides can operate independently.
- When used as 3-port valves, only half the number of stations is required.
- Can also be used as a 4-position, 5-port valve.

Built-in Back Pressure Check Valve (Option symbol: B)

Eliminates trouble with back pressure when driving a single acting cylinder or when using an exhaust center type valve, etc.

Easy valve maintenance
Mountable with one screw.

Easy to add or decrease the number of valve stations.



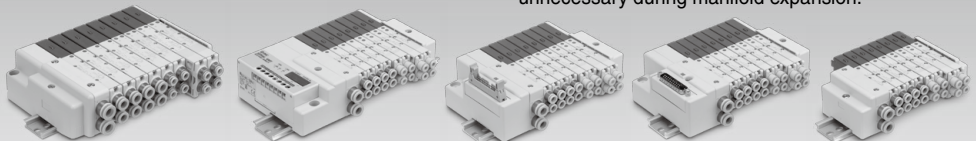

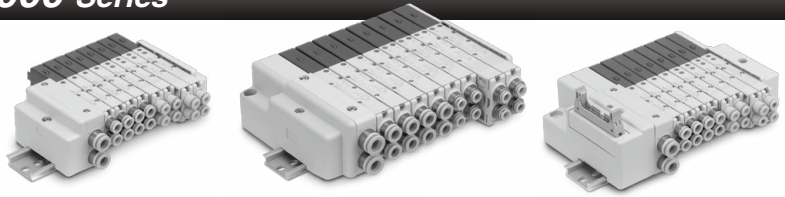

The use of cassette type valves and manifolds makes it easy to increase or decrease the number of stations on a DIN rail. The plug-in type includes two extra valve station connectors. This design makes rewiring unnecessary during manifold expansion.

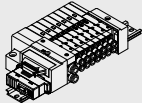
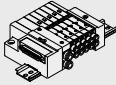
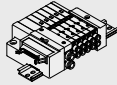
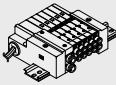
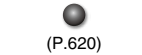
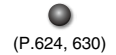

SQ1000/2000 Series

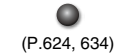

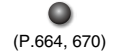
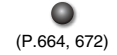
Wiring Type

Manifold variations		EX510 Gateway-type serial transmission system	D-sub connector kit	Flat ribbon cable connector kit	Terminal block box kit	Lead wire kit
			F kit	P kit	T kit	L kit
Plug-in Unit	SQ1000	 (P.602)	 (P.606, 612)	 (P.606, 614)	—	 (P.606, 616)
	SQ2000	 (P.620)	 (P.624, 630)	 (P.624, 632)	 (P.624, 634)	 (P.624, 636)
Plug Lead Unit	SQ1000	—	 (P.664, 670)	 (P.664, 672)	—	—
	SQ2000	—	 (P.676, 682)	 (P.676, 684)	—	—

Piping Specifications

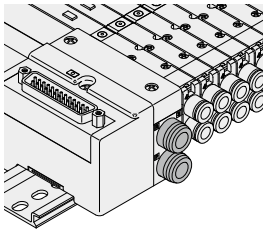
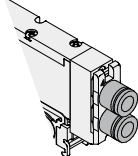
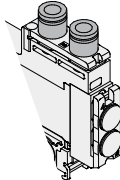
1(P), 3(R)	4(A), 2(B)
<p>○Supply/Exhaust port</p>  <p>SQ1000 One-touch fittings for $\phi 8$</p> <p>SQ2000 One-touch fittings for $\phi 10$</p>	<p>○Cylinder port</p> <p>Side ported</p>  <p>SQ1000 One-touch fittings for $\phi 3.2$ One-touch fittings for $\phi 4$ One-touch fittings for $\phi 6$ M5</p> <p>SQ2000 One-touch fittings for $\phi 4$ One-touch fittings for $\phi 6$ One-touch fittings for $\phi 8$</p> <p>Top ported</p>  <p>Top porting can be changed to side porting.</p>

Metal Seal/Rubber Seal 5 Port Solenoid Valve

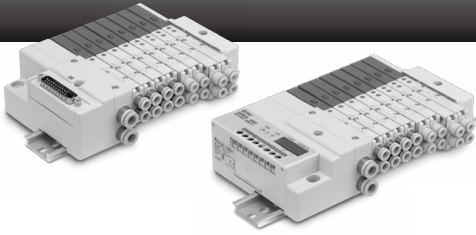

Contents







■ Plug-in Unit

Valve Specifications	P.610
Manifold Specifications	P.611
Manifold Option Parts	P.639
How to Increase Manifold Stations	P.653
Construction	P.658
Manifold Exploded View: SQ1000	P.660
Manifold Spare Parts: SQ1000	P.661
Manifold Exploded View: SQ2000	P.662
Manifold Spare Parts: SQ2000	P.663

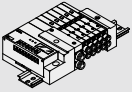
■ Plug Lead Unit

Valve Specifications	P.668
Manifold Specifications	P.669
Manifold Option Parts	P.688
How to Increase Manifold Stations	P.701
Construction	P.704
Manifold Exploded View: SQ1000	P.706
Manifold Spare Parts: SQ1000	P.707
Manifold Exploded View: SQ2000	P.708
Manifold Spare Parts: SQ2000	P.709

Specific Product Precautions	P.710
------------------------------------	-------

Serial transmission kit	Connector kit	Manifold options	
S kit	C kit		
			
	—		P.608
(P.606, 618)			
	—		P.626
(P.624, 638)			
—			P.666
	(P.664, 674)		
—			P.678
	(P.676, 686)		

Cylinder Speed Chart

Use as a guide for selection. Please confirm the actual conditions with SMC Sizing Program.

SQ1000 series

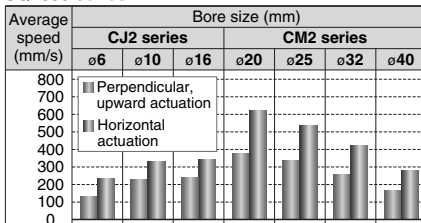

SQ2000 series

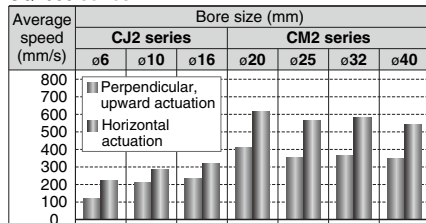

* It is when the cylinder is extending that is meter-out controlled by speed controller which is directly connected with cylinder, and its needle valve with being fully open.

* The average velocity of the cylinder is what the stroke is divided by the total stroke time.

* Load factor: ((Load mass x 9.8) / Theoretical force) x 100%

Pressure: 0.5 MPa/Load factor: 50%

Conditions

	Base mounted	CJ2 series	CM2 series	MB, CA2 series
SQ1000	Tube x Length		T0604 x 1 m	
	Speed controller		AS3002F-06	
	Silencer		AN110-01	
SQ2000	Tube x Length	T0604 x 1 m	T1075 x 1 m	T1209 x 1 m
	Speed controller	AS3002F-06		AS4002F-10
	Silencer		AN20-02	

EX510 Gateway-type Serial Transmission System Plug-in Unit

SQ1000 Series



How to Order Manifold

SS5Q 1 3 - SB [] 08 - D [] - [] - []

Manifold series

1	SQ1000
---	--------

SI unit output polarity

Nil	Positive common
N	Negative common

Valve stations

Symbol	Stations	Note
01	1 station	Double Wiring
⋮	⋮	
08	8 stations	

Note) Max. 16 stations (Special wiring specifications)

CE/UKCA-compliant

Nil	—
Q	CE/UKCA-compliant

1(P), 3(R) port size

Nil	1(P), 3(R) port, One-touch fittings for ø8
00T	1(P), 3(R) port, One-touch fittings for ø5/16"

Option

Nil	None
02 to 16 (1)	DIN rail length specified
B (2)(3)	Back pressure check valve
K (4)	Special wiring specifications (Except double wiring)
N	With name plate (Side ported only)
R	External pilot specifications
S	Built-in silencer, direct exhaust

Note 1) Specify DIN rail length with "D□" at the end.
(Enter the number of stations inside □.)
The number of stations that may be displayed is longer than the manifold number of stations.
Example: -D09

Note 2) When "B" is selected, a back pressure check valve is included in all stations of the manifold. If the back pressure check valve is used only for the station that need it, then specify the station location in the manifold specification.
("B" is not necessary)

Note 3) Since 4 port specification valves (5 (R1) and 3 (R2) are common) are used, back pressure cannot be prevented with dual 3 port valves.

Note 4) Specify "K" for wiring specification for cases below.

- All single wiring
- Single and double mixed wiring
- When there are stations which do not require wiring (e.g. single SUP spacer), specify the wiring specification in the manifold specification so that the number of the solenoids is 16 maximum. (Standard wiring specification is double wiring)

Note 5) For specifying two or more options, enter them alphabetically.
Example: -BKN

* Refer to pages 639 to 643 and 649 to 651 for manifold option parts.

DIN rail mounting

How to Order Manifold Assembly

Example

SS5Q13-SB08-D 1 set (SB kit 8-station manifold base part no.)
SQ1130-51-C6 4 sets (Single type part no.)
SQ1230D-51-C6 3 sets (Double type part no.)
SSQ1000-10A-3 1 set (Blanking plate part no.)

→ The asterisk denotes the symbol for assembly.
 Prefix it to the part nos. of the solenoid valve, etc.
 Enter in order starting from the first station on the D side.

Add the valve and option part number under the manifold base part number.
 When entry of part numbers becomes complicated, indicate by the manifold specification sheet.

SI Unit Part No.

Symbol	SI Unit Specifications	SI unit part no.	Page
Nil	Positive common (NPN)	EX510-S002B	Web Catalog
N	Negative common (PNP)	EX510-S102B	

Refer to the **Web Catalog** and the Operation Manual for the details of EX510 Gateway-type Serial Transmission System.
 Please download it via our website, <https://www.smcworld.com>

How to Order Valves

SQ 1 1 3 0 - 5 1 - C6 - - -

Series

1	SQ1000
---	--------

Seal

0	Metal seal
1	Rubber seal

Type of actuation

1	2 position single	
	(A)4 2(B) (R1)5 1 3(R2) (P)	
2	2 position double (Double solenoid) ⁽¹⁾	
	(A)4 2(B) (A)4 2(B) (R1)5 1 3(R2) (R1)5 1 3(R2) (P) (P) Metal seal Rubber seal	
3	3 position closed center	
	(A)4 2(B) (R1)5 1 3(R2) (P)	
4	3 position exhaust center	
	(A)4 2(B) (R1)5 1 3(R2) (P)	
5	3 position pressure center	
	(A)4 2(B) (R1)5 1 3(R2) (P)	
A ⁽²⁾	4 position dual 3 port valve	
	4(A) 2(B) 1(P) 3(R)	
B ⁽²⁾	4 position dual 3 port valve	
	4(A) 2(B) 1(P) 3(R)	
C ⁽²⁾	4 position dual 3 port valve	
	4(A) 2(B) 1(P) 3(R)	

Note 1) For double solenoid specification, the function symbol below is "D".

Note 2) Only rubber seal types are applicable.

Function

Symbol	Specifications
N (l)	Standard type (0.4 W)
B (5)	Quick response type (0.95 W)
D (1)	2 position double (Double solenoid specifications)
K (5)	High pressure type (1 MPa, 0.95 W) [Applicable to metal seal only]
N (2)	Negative common
R (3)	External pilot specifications

CE/UKCA-compliant

N (l)	—
Q	CE/UKCA-compliant

With/Without manifold block

Nil	M	MB ^{Note)}
Without manifold block 	With manifold block 	With manifold block, built-in back pressure check valve
<ul style="list-style-type: none"> When ordering with manifolds When only valves are required. 		<ul style="list-style-type: none"> * Lead wire is not included. * Lead wire is not included.
For adding stations		

Note) Since 4 port specification valves (5 (R1) and 3 (R2) are common) are used, back pressure cannot be prevented with dual 3 port valves.

Port plug mounting port

N (l)	None
A	Port 4(A)
B	Port 2(B)

Cylinder port

Symbol	Port size	Port location	
C3	With One-touch fittings for ø3.2	Side ported	
C4	With One-touch fittings for ø4		
C6	With One-touch fittings for ø6		
M5	M5 thread	Top ⁽¹⁾ ported	
L3	With One-touch fittings for ø3.2		
L4	With One-touch fittings for ø4		
L6	With One-touch fittings for ø6		
L5	M5 thread		

Note 1) Can be changed to side ported configuration.

Note 2) Refer to page 651 for the inch-size One-touch fittings.

Manual override

Nil	B
Non-locking push type (Tool required)	Locking type (Tool required)

Rated voltage

5	24 VDC
----------	--------

Note) Light/surge voltage suppressor is built-in.

Note 1) "D" is specified for 2 position double.

Note 2) When SI unit output polarity is negative common, the valve common specification should be also be negative common.

Note 3) Except dual 3 port valves.

Note 4) When two or more symbols are specified, indicate them alphabetically.

Note 5) Function combination of "B" and "K" is not available.

SQ1000 Series

Dimensions: SQ1000

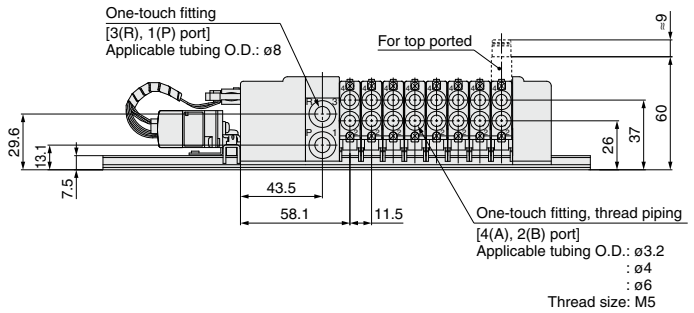
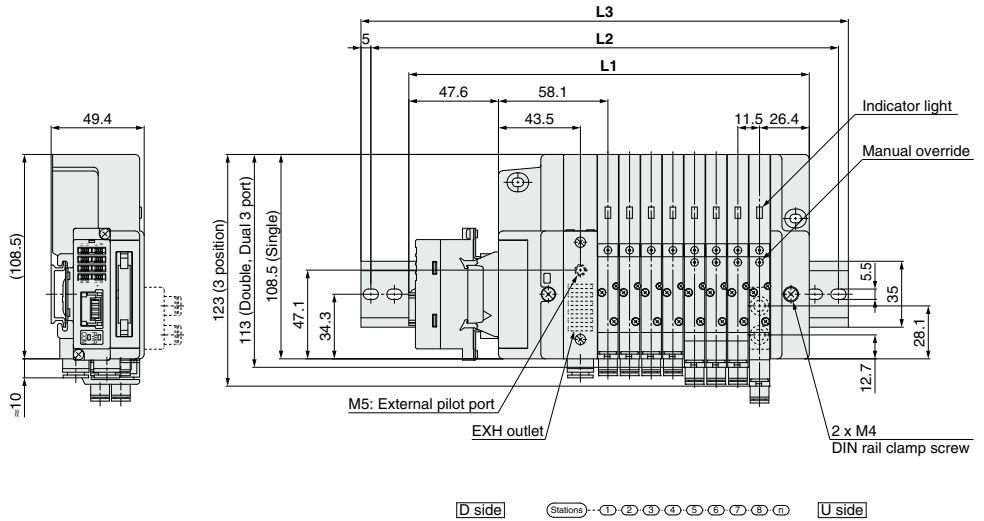

Dimensions

Formula: $L1 = 11.5n + 120.5$ n: Stations (Maximum 16 stations)

L	n	1	2	3	4	5	6	7	8	9	10	11	12	13	14	15	16
L1		132	143.5	155	166.5	178	189.5	201	212.5	224	235.5	247	258.5	270	281.5	293	304.5
L2		162.5	175	175	187.5	200	212.5	225	237.5	250	262.5	275	287.5	300	312.5	312.5	325
L3		173	185.5	185.5	198	210.5	223	235.5	248	260.5	273	285.5	298	310.5	323	323	335.5

Plug-in Unit

SQ1000 Series



(Option)

How to Order Manifold

SS5Q13-08 FD2-D

Stations

01	1 station
⋮	⋮
24 (Note)	24 stations

Note) The maximum number of stations depends on the type of electrical entries. Refer to "Electrical entry" for details.

1(P), 3(R) port size

Nil	1(P), 3(R) port One-touch fittings for ø8
00T	1(P), 3(R) port One-touch fittings for ø5/16"

CE/UKCA-compliant

Nil	—
Q	CE/UKCA-compliant

Manifold mounting

D	DIN rail mounting type
E (Note)	Direct mounting type

Note) Refer to page 650 for details.

Option

Nil	None
02 to 24(1)	DIN rail length specified
B(2)(3)	Back pressure check valve
K(4)	Special wiring specifications (Except double wiring)
N	With name plate (Side ported only)
R	External pilot specifications
S	Built-in silencer, direct exhaust

Note 1) Specify DIN rail length with "D□" at the end. (Enter the number of stations inside□.) The number of stations that may be displayed is longer than the manifold number of stations. Example: -D09

Note 2) When "B" is selected, a back pressure check valve is included in all stations of the manifold. If the back pressure check valve is used only for the station that need it, then specify the station location in the manifold specification. ("B" is not necessary)

Note 3) Since 4 port specification valves (5 (R1) and 3 (R2) are common) are used, back pressure cannot be prevented with dual 3 port valves.

Note 4) Specify "K" for wiring specification for cases below. (Except L kit)

- All single wiring
- Single and double mixed wiring.
- When there are stations which do not require wiring (e.g. single SUP spacer), specify the wiring specification in the manifold specification so that the number of solenoids is the maximum number of solenoids or less. (Standard wiring specification is double wiring)

Note 5) For specifying two or more options, enter them alphabetically. Example: -BKN

* Refer to pages 639 to 643 and 649 to 651 for manifold option parts.

Electrical entry

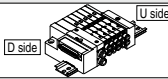
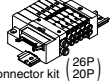
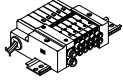
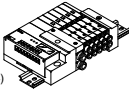
Kit type	Lead wire connector location	Cable/SI unit specifications	Station (Double wiring)	Max. number of solenoids for special wiring specifications(2)
F kit  D-sub connector kit	FD0	D-sub connector (25P) kit, without cable	1 to 12 stations	24
	FD1	D-sub connector (25P) kit, with 1.5 m cable		
	FD2	D-sub connector (25P) kit, with 3.0 m cable		
	FD3	D-sub connector (25P) kit, with 5.0 m cable		
P kit  Flat ribbon cable connector kit (26P/20P)	PD0	Flat ribbon cable (26P) kit, without cable	1 to 12 stations	24
	PD1	Flat ribbon cable (26P) kit, with 1.5 m cable		
	PD2	Flat ribbon cable (26P) kit, with 3.0 m cable		
	PD3	Flat ribbon cable (26P) kit, with 5.0 m cable		
	PD4	Flat ribbon cable (20P) kit, without cable		
L kit Note 3)  Lead wire kit	LD0 (N)	Lead wire kit with 0.6 m cable	1 to 12 stations	—
	LU0 (N)	U side		
	LD1 (N)	D side		
	LU1 (N)	U side		
	LD2 (N)	D side		
	LU2 (N)	U side		
S kit Serial transmission kit EX140 Integrated-type (For Output) Serial Transmission System(4) 	SDQ	DeviceNet®	1 to 8 stations	16
	SDR1	OMRON Corp.: CompoBus/S (16 output points)	1 to 4 stations	8
	SDR2	OMRON Corp.: CompoBus/S (8 output points)		
	SDV	CC-LINK		

Note 1) Separately order the 20P type cable assembly for the P kit.

Note 2) Specify the wiring so that the maximum number of solenoids is not exceeded. (The number of solenoids are counted as: 1 for single solenoids and 2 for type 3P and 4P double solenoids.)

Note 3) When specifying the negative common specifications of the L kit, suffix "N" to the kit symbol. For details, refer to page 616.

Note 4) Refer to the Web Catalog and the Operation Manual for the details of EX140 Integrated-type (For Output) Serial Transmission System. Please download it via our website. <https://www.smcworld.com>

* Refer to page 661 for manifold spare parts.

SI Unit Part No.

Symbol	Protocol type	SI unit part no.	Page
SDQ	DeviceNet®	EX140-SDN1	Web Catalog
SDR1	OMRON Corp.: CompoBus/S (16 output points)	EX140-SCS1	
SDR2	OMRON Corp.: CompoBus/S (8 output points)	EX140-SCS2	
SDV	CC-LINK	EX140-SMJ1	

How to Order Valves

SQ1 1 3 0 - **5** - **1** - **C6** - - -

Seal

0	Metal seal
1	Rubber seal

CE/UKCA-compliant

Nil	—
Q	CE/UKCA-compliant

Type of actuation

1	2 position single (A)4 2(B) (R1)5 1 3(R2) (P)
2	2 position double (Double solenoid) (1) (A)4 2(B) (A)4 2(B) (R1)5 1 3(R2) (R1)5 1 3(R2) (P) (P) Metal seal Rubber seal
3	3 position closed center (A)4 2(B) (R1)5 1 3(R2) (P)
4	3 position exhaust center (A)4 2(B) (R1)5 1 3(R2) (P)
5	3 position pressure center (A)4 2(B) (R1)5 1 3(R2) (P)
A(2)	4 position dual 3 port valve 4(A) 2(B) 1(P) 3(R)
B(2)	4 position dual 3 port valve 4(A) 2(B) 1(P) 3(R)
C(2)	4 position dual 3 port valve 4(A) 2(B) 1(P) 3(R)

Note 1) For double solenoid specification, the function symbol below is "D".
Note 2) Only rubber seal types are applicable.

With/Without manifold block

Nil	M	MB (Note)
Without manifold block 	With manifold block 	With manifold block, built-in back pressure check valve
* Lead wire is not included.		* Lead wire is not included.
For adding stations		

- When ordering with manifolds
- When only valves are required.

Note) Since 4 port specification valves (5 (R1) and 3 (R2) are common) are used, back pressure cannot be prevented with dual 3 port valves.

Port plug mounting port

Nil	None
A	Port 4(A)
B	Port 2(B)

Cylinder port

Symbol	Port size	Port location	
C3	With One-touch fittings for ø3.2	Side ported	
C4	With One-touch fittings for ø4		
C6	With One-touch fittings for ø6		
M5	M5 thread	Top ⁽¹⁾ ported	
L3	With One-touch fittings for ø3.2		
L4	With One-touch fittings for ø4		
L6	With One-touch fittings for ø6		
L5	M5 thread		

Note 1) Can be changed to side ported configuration.
Note 2) Refer to page 651 for the inch-size One-touch fittings.

Manual override

Nil	B
Non-locking push type (Tool required)	Locking type (Tool required)

Rated voltage

5	24 VDC
6	12 VDC

Note 1) Light/surge voltage suppressor is built-in.
Note 2) S kit: 24 VDC only

Function

Symbol	Specifications
Nil	Standard type (0.4 W)
B(5)	Quick response type (0.95 W)
D(1)	2 position double (Double solenoid specifications)
K(5)	High pressure type (1 MPa, 0.95 W) [Applicable to metal seal only]
N(2)	Negative common
R(3)	External pilot specifications

Note 1) "D" is specified for 2 position double.
Note 2) For L kit, when the manifold specifies negative common, the valve common should also be negative. The combination of negative common of the valve cannot be specified with S kit (EX140).
Note 3) Except dual 3 port valves.
Note 4) When two or more symbols are specified, indicate them alphabetically.
Note 5) Function combination of "B" and "K" is not available.

SQ1000 Series

Manifold Options

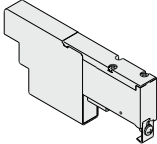
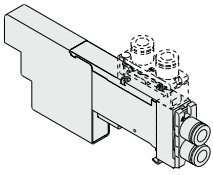
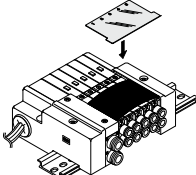
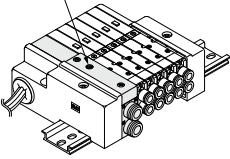
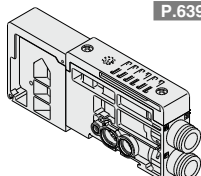
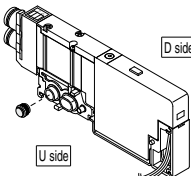
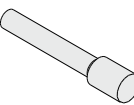
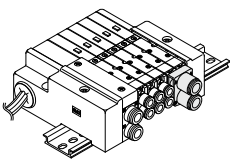
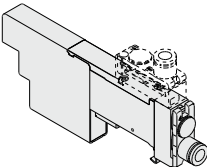
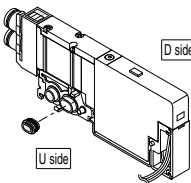
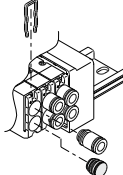
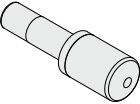
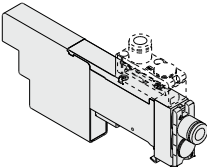
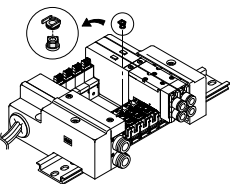
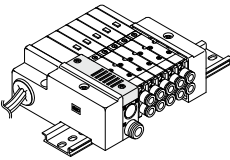
<p>Blanking plate SSQ1000-10A-3 P.639</p> 	<p>Individual SUP/EXH spacer SSQ1000-PR1-3-C₆-L₆ P.640</p> 	<p>Name plate (-N) SSQ1000-N3-n P.642</p> 	<p>External pilot specifications (-R) P.643 External pilot port</p> 																																							
<p>SUP/EXH block SSQ1000-PR-3-C8(-S) P.639</p> 	<p>SUP block plate SSQ1000-B-P P.641</p> 	<p>Blanking plug KQ2P-23/04/06/08 P.642</p> 	<p>Dual flow fitting SSQ1000-52A-C₈-N₉ P.643</p> 																																							
<p>Individual SUP spacer SSQ1000-P-3-C₆-L₆ P.639</p> 	<p>EXH block plate SSQ1000-B-R P.641</p> 	<p>Port plug VVQZ100-CP P.642</p> 	<p>Silencer (For EXH port) P.643</p> 																																							
<p>Individual EXH spacer SSQ1000-R-3-C₆-L₆ P.640</p> 	<p>Back pressure check valve (-B) SSQ1000-BP P.641</p> 	<p>Built-in silencer, direct exhaust (-S) P.642</p> 	<p>Special wiring specifications (-K) P.649</p> <p>D-sub connector</p> <table border="0"> <tr> <td>1 station</td> <td>SOLA</td> <td>o 1 (-)</td> </tr> <tr> <td>2 stations</td> <td>SOLA</td> <td>o14 (-)</td> </tr> <tr> <td>3 stations</td> <td>SOLA</td> <td>o 2 (-)</td> </tr> <tr> <td>4 stations</td> <td>SOLA</td> <td>o15 (-)</td> </tr> <tr> <td>5 stations</td> <td>SOLB</td> <td>o 3 (-)</td> </tr> <tr> <td>6 stations</td> <td>SOLB</td> <td>o16 (-)</td> </tr> <tr> <td>7 stations</td> <td>SOLB</td> <td>o 4 (-)</td> </tr> <tr> <td>8 stations</td> <td>SOLB</td> <td>o17 (-)</td> </tr> <tr> <td></td> <td>SOLA</td> <td>o 5 (-)</td> </tr> <tr> <td></td> <td>SOLA</td> <td>o18 (-)</td> </tr> <tr> <td></td> <td>SOLA</td> <td>o 6 (-)</td> </tr> <tr> <td></td> <td>SOLB</td> <td>o19 (-)</td> </tr> <tr> <td></td> <td>COM.</td> <td>o13 (+)</td> </tr> </table> <p>Connector terminal no.</p> <p>Although the standard products come with double wiring, mixed single and double wiring is available upon request.</p>	1 station	SOLA	o 1 (-)	2 stations	SOLA	o14 (-)	3 stations	SOLA	o 2 (-)	4 stations	SOLA	o15 (-)	5 stations	SOLB	o 3 (-)	6 stations	SOLB	o16 (-)	7 stations	SOLB	o 4 (-)	8 stations	SOLB	o17 (-)		SOLA	o 5 (-)		SOLA	o18 (-)		SOLA	o 6 (-)		SOLB	o19 (-)		COM.	o13 (+)
1 station	SOLA	o 1 (-)																																								
2 stations	SOLA	o14 (-)																																								
3 stations	SOLA	o 2 (-)																																								
4 stations	SOLA	o15 (-)																																								
5 stations	SOLB	o 3 (-)																																								
6 stations	SOLB	o16 (-)																																								
7 stations	SOLB	o 4 (-)																																								
8 stations	SOLB	o17 (-)																																								
	SOLA	o 5 (-)																																								
	SOLA	o18 (-)																																								
	SOLA	o 6 (-)																																								
	SOLB	o19 (-)																																								
	COM.	o13 (+)																																								

How to Order Manifold Assembly

Example: D-sub connector kit, with cable (3 m)

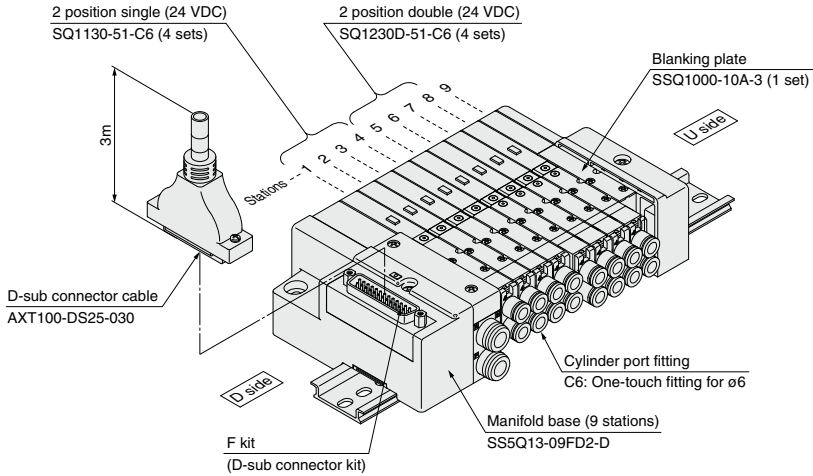

- SS5Q13-09FD2-D 1 set (F kit 9-station manifold base)**
*** SQ1130-51-C6 4 sets (2 position single)**
*** SQ1230D-51-C6 4 sets (2 position double)**
*** SSQ1000-10A-3 1 set (Blanking plate)**

The asterisk denotes the symbol for assembly. Prefix it to the part nos. of the solenoid valve, etc.

Add the valve and option part numbers in order starting from the first station on the D side.
 When entry of part numbers becomes complicated, indicate on the manifold specification sheet.

SQ1000 Series

Valve Specifications

Model

Series	Type of actuation	Seal	Model	Flow rate characteristic (1)						Response time (ms) (2)		Weight (g)	
				1 → 4/2 (P → A/B)			4 → 5 (A → R1)			Standard (0.4 W)	Quick response (0.95 W)		
				C [dm ³ /(s·bar)]	b	Cv	C [dm ³ /(s·bar)]	b	Cv				
SQ1000	2 position	Single	Metal seal	SQ1130	0.62	0.10	0.14	0.63	0.11	0.14	26 or less	12 or less	80
			Rubber seal	SQ1131	0.79	0.20	0.19	0.80	0.20	0.19	24 or less	15 or less	80
		Double	Metal seal	SQ1230D	0.62	0.10	0.14	0.63	0.11	0.14	13 or less	10 or less	95
			Rubber seal	SQ1231D	0.79	0.20	0.19	0.80	0.20	0.19	20 or less	15 or less	95
	3 position	Closed center	Metal seal	SQ1330	0.58	0.12	0.14	0.63	0.11	0.14	44 or less	29 or less	100
			Rubber seal	SQ1331	0.64	0.20	0.15	0.58	0.26	0.16	39 or less	25 or less	100
		Exhaust center	Metal seal	SQ1430	0.58	0.12	0.14	0.60	0.14	0.14	44 or less	29 or less	100
			Rubber seal	SQ1431	0.64	0.20	0.15	0.80	0.20	0.19	39 or less	25 or less	100
		Pressure center	Metal seal	SQ1530	0.62	0.12	0.14	0.63	0.14	0.14	44 or less	29 or less	100
			Rubber seal	SQ1531	0.79	0.21	0.19	0.59	0.20	0.14	39 or less	25 or less	100
	4 position	Dual 3 port valve	Rubber seal	SQ1631	0.59	0.28	0.15	0.59	0.28	0.15	27 or less	14 or less	95

Note 1) Values for the cylinder port size of C6, CYL → Values of EXH. Flow rate characteristics of 2 → 3 (B → R2) declines about 30% of 4 → 5 (A → R1).
 Note 2) Based on JIS B 8419: 2010. (Values with a supply pressure of 0.5 MPa and light/surge voltage suppressor. Values fluctuate depending on the pressure and air quality.)

Specifications



Valve specifications	Valve construction	Metal seal	Rubber seal	
	Fluid	Air		
	Maximum operating pressure	0.7 MPa (High pressure type (3): 1.0 MPa)		
	Min. operating pressure	Single	0.1 MPa	0.15 MPa
		Double (Double solenoid)	0.1 MPa	0.1 MPa
		3 position	0.1 MPa	0.2 MPa
		4 position	—	0.15 MPa
	Ambient and fluid temp.	-10 to 50°C (1)		
	Lubrication	Not required		
	Pilot valve manual override	Push type/Locking type (Tool required)		
Vibration/Impact resistance (2)	30/150 m/s ²			
Protection structure	Dust tight			
Solenoid specifications	Coil rated voltage	12 VDC, 24 VDC		
	Allowable voltage fluctuation	±10% of rated voltage		
	Coil insulation type	Equivalent to class B		
	Power consumption (Current)	24 VDC	0.4 W DC (17 mA), 0.95 W DC (40 mA) (4)	
	12 VDC	0.4 W DC (34 mA), 0.95 W DC (80 mA) (4)		

Note 1) Use dry air to prevent condensation when operating at low temperatures.

Note 2) Vibration resistance: No malfunction occurred in a one-sweep test between 45 and 2000 Hz. Test was performed at both energized and de-energized states in the axial direction and at the right angles to the main valve and armature. (Values at the initial period)

Impact resistance: No malfunction occurred when it is tested with a drop tester in the axial direction and at the right angles to the main valve and armature in both energized and deenergized states every once for each condition.

Note 3) Metal seal type only.

Note 4) Value for quick response, high pressure type

Symbol

2 position single

(A)4 2(B)



(R1)5 13(R2)

(P)

2 position double (Double solenoid)

(A)4 2(B) (A)4 2(B)



(R1)5 13(R2) (R1)5 13(R2)

(P) (P)

Metal seal Rubber seal

3 position closed center

(A)4 2(B)



(R1)5 13(R2)

(P)

3 position exhaust center

(A)4 2(B)



(R1)5 13(R2)

(P)

3 position pressure center

(A)4 2(B)



(R1)5 13(R2)

(P)

4 position dual 3 port valve (A)

4(A) 2(B)

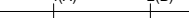

1(P) 3(R)

4 position dual 3 port valve (B)

4(A) 2(B)



1(P) 3(R)

4 position dual 3 port valve (C)

4(A) 2(B)

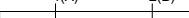

1(P) 3(R)

Manifold Specifications

Base model	Porting specifications			Applicable solenoid valve	Type of connection	Applicable stations (3) (Double wiring)	5-station weight (4) (g)	Addition per station (4) (g)	
	Port size (1)								
	1(P), 3(R)	Port location	4(A), 2(B)						
SS5Q13-□□-□	C8 (For ø8)	Side	C3 (For ø3.2)	SQ1□30 SQ1□31	F kit: D-sub connector		1 to 12 stations	420	20
			C4 (For ø4)		P kit: Flat ribbon cable		26P	1 to 12 stations	420
	C6 (For ø6)	L kit: Lead wire			20P	1 to 9 stations	460	35	
	M5 (M5 thread)	S kit: Serial transmission				1 to 8 stations	475	20	
	Option Built-in silencer, (direct exhaust)	Top (2)	L3 (For ø3.2)						
			L4 (For ø4)						
			L6 (For ø6)						
			L5 (M5 thread)						

Note 1) One-touch fittings in inch sizes are also available. For details, refer to page 651.

Note 2) Can be changed to side ported configuration.

Note 3) An optional specification for special wiring is available to increase the maximum number of stations. Refer to page 649 for details.

Note 4) Except valves. For valve weight, refer to page 610.

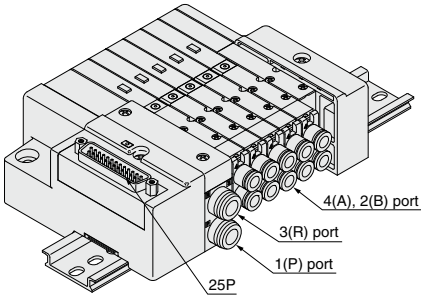

F kit

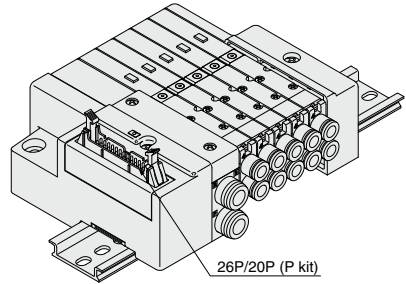

P kit

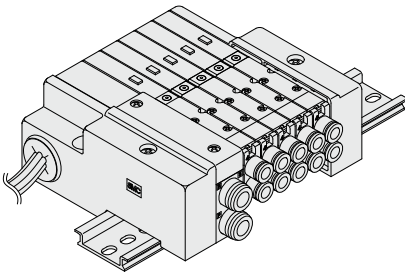

L kit

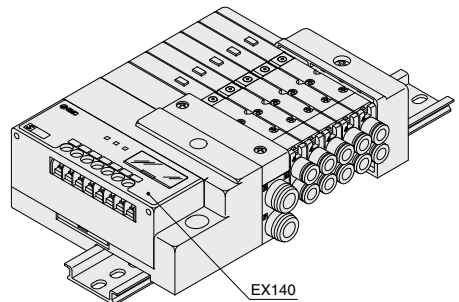

Refer to the **Web Catalog** and the Operation Manual for the details of EX140 Integrated-type (For Output) Serial Transmission System. Please download it via our website, <https://www.smcworld.com>

S kit

SQ1000 Series

F Kit (D-sub Connector Kit)

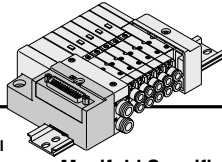

- The D-sub connector reduces installation labor for electrical connections.
- Using the D-sub connector (25P), conforming to MIL standard permits the use of connectors put on the market and gives a wide interchangeability.
- Top or side receptacle position can be selected in accordance with the available mounting space.

Manifold Specifications

Series	Port location	Porting specifications		Maximum number of stations
		1(P), 3(R)	4(A), 2(B)	
SQ1000	Side, Top	C8	C3,C4,C6,M5	12 stations (24 as a semi-standard)

D-sub Connector (25 Pins)

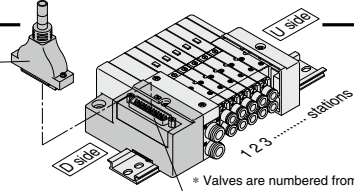

015
AXT100-DS25-030
050

(The D-sub connector cable assemblies can be ordered with manifolds. Refer to "How to Order Manifold.")

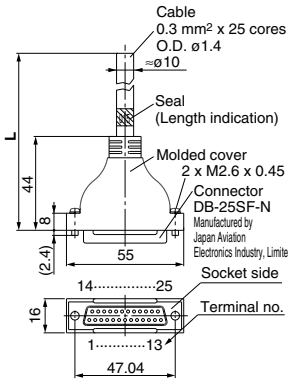

Cable Assembly

D-sub Connector Cable Assembly Terminal No.

Terminal number	Lead wire color	Dot marking
1	Black	None
2	Brown	None
3	Red	None
4	Orange	None
5	Yellow	None
6	Pink	None
7	Blue	None
8	Purple	White
9	Gray	Black
10	White	Black
11	White	Red
12	Yellow	Red
13	Orange	Red
14	Yellow	Black
15	Pink	Black
16	Blue	White
17	Purple	None
18	Gray	None
19	Orange	Black
20	Red	White
21	Brown	White
22	Pink	Red
23	Gray	Red
24	Black	White
25	White	None

D-sub Connector Cable Assembly

Cable length (L)	Assembly part no.	Note
1.5 m	AXT100-DS25-015	Cable
3 m	AXT100-DS25-030	0.3 mm² x 25 cores
5 m	AXT100-DS25-050	25 cores

* For other commercial connectors, use a 25 pins type with female connector conforming to MIL-C-24308.

* Cannot be used for movable wiring.

* Lengths other than the above are also available. Please contact SMC for details.

Electrical Characteristics

Item	Property
Conductor resistance Ω/km, 20°C	65 or less
Withstand voltage VAC, 1 min.	1000
Insulation resistance MΩ/km, 20°C	5 or more

Note) The minimum bending inner radius of D-sub connector cable is 20 mm.

Connector manufacturers' example

- Fujitsu Limited
- Japan Aviation Electronics Industry, Limited
- J.S.T. Mfg. Co., Ltd.
- HIROSE ELECTRIC CO., LTD.

Electrical Wiring Specifications

D-sub connector

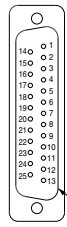

As the standard electrical wiring specifications, double wiring (connected to SOL. A and SOL. B) is adopted for the internal wiring of each station for 12 stations or less, regardless of valve and option types. Mixed single and double wiring is available as an option. For details, refer to page 649.

Connector terminal no.

D-sub connector assembly wire colors (AXT100-DS25-015/030/050)

Terminal no.	Polarity	Lead wire color	Dot marking
1 station	SOL_a 1 (-)	(+) Black	None
	SOL_b 14 (-)	(+) Yellow	Black
2 stations	SOL_a 2 (-)	(+) Brown	None
	SOL_b 15 (-)	(+) Pink	Black
3 stations	SOL_a 3 (-)	(+) Red	None
	SOL_b 16 (-)	(+) Blue	White
4 stations	SOL_a 4 (-)	(+) Orange	None
	SOL_b 17 (-)	(+) Purple	None
5 stations	SOL_a 5 (-)	(+) Yellow	None
	SOL_b 18 (-)	(+) Gray	None
6 stations	SOL_a 6 (-)	(+) Pink	None
	SOL_b 19 (-)	(+) Orange	Black
7 stations	SOL_a 7 (-)	(+) Blue	None
	SOL_b 20 (-)	(+) Red	White
8 stations	SOL_a 8 (-)	(+) Purple	White
	SOL_b 21 (-)	(+) Brown	White
9 stations	SOL_a 9 (-)	(+) Gray	Black
	SOL_b 22 (-)	(+) Pink	Red
10 stations	SOL_a 10 (-)	(+) White	Black
	SOL_b 23 (-)	(+) Gray	Red
11 stations	SOL_a 11 (-)	(+) White	Red
	SOL_b 24 (-)	(+) Black	White
12 stations	SOL_a 12 (-)	(+) Yellow	Red
	SOL_b 25 (-)	(+) White	None
COM.	13 (+)	(-) Orange	Red

Note) When using the negative common specifications, use valves for negative common.

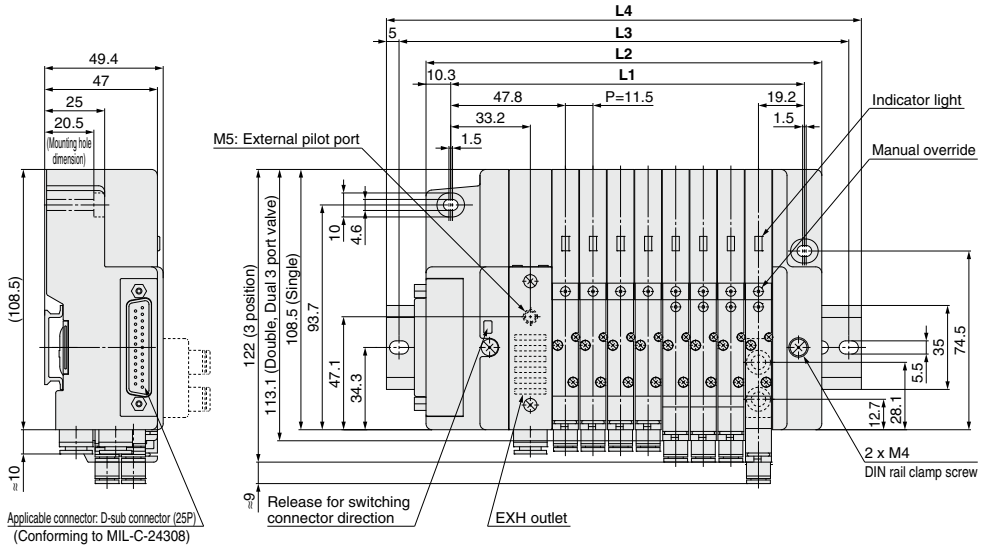

D side Stations 1 2 3 4 5 6 7 8 ... n U side

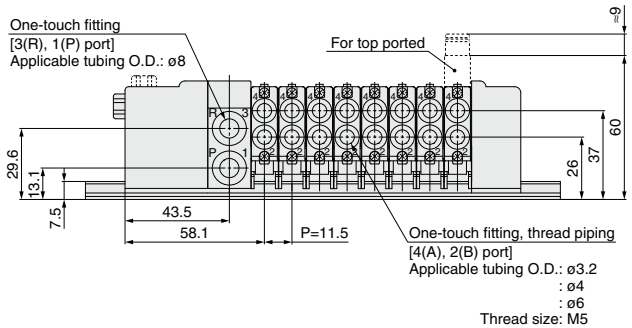

Dimensions

Formula: $L1 = 11.5n + 55.5$, $L2 = 11.5n + 73$ n: Stations (Maximum 24 stations)

L	n	1	2	3	4	5	6	7	8	9	10	11	12	13	14	15	16	17	18	19	20	21	22	23	24
L1		67	78.5	90	101.5	113	124.5	136	147.5	159	170.5	182	193.5	205	216.5	228	239.5	251	262.5	274	285.5	297	308.5	320	331.5
L2		84.5	96	107.5	119	130.5	142	153.5	165	176.5	188	199.5	211	222.5	234	245.5	257	268.5	280	291.5	303	314.5	326	337.5	349
L3		112.5	125	137.5	150	162.5	175	187.5	200	212.5	225	237.5	250	262.5	275	287.5	300	300	312.5	325	337.5	350	362.5	375	
L4		123	135.5	148	160.5	173	185.5	198	210.5	223	235.5	248	260.5	273	285.5	298	310.5	310.5	323	335.5	348	360.5	373	385.5	

SQ1000 Series

P Kit (Flat Ribbon Cable Connector)

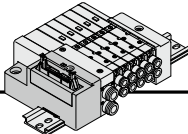

- Flat ribbon cable connector reduces installation labor for electrical connection.
- Using the connector for flat ribbon cable (26P, 20P) conforming to MIL standard permits the use of connectors put on the market and gives a wide interchangeability.
- Top or side receptacle position can be selected in accordance with the available mounting space.

Manifold Specifications

Series	Porting specifications Port location	Port size		Maximum number of stations (24 as a semi-standard)
		1(P), 3(R)	4(A), 2(B)	
SQ1000	Side, Top	C8	C3, C4, C6, M5	12 stations

Flat Ribbon Cable (26 Pins, 20 Pins)

AXT100-FC ¹/₂₆ ²/₂₆ ³/₃

(Type 26P flat ribbon cable connector assemblies can be ordered with manifolds. Refer to "How to Order Manifold".)

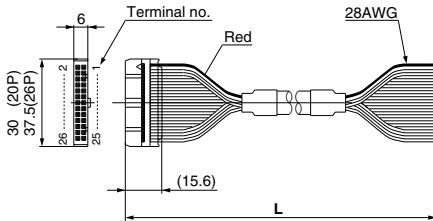

Flat Ribbon Cable Connector Assembly

Cable length (L)	Assembly part no.	
	26P	20P
1.5 m	AXT100-FC26-1	AXT100-FC20-1
3 m	AXT100-FC26-2	AXT100-FC20-2
5 m	AXT100-FC26-3	AXT100-FC20-3

- * For other commercial connectors, use a 26 pins or 20 pins with strain relief conforming to MIL-C-83503.
- * Cannot be used for movable wiring.
- * Lengths other than the above are also available. Please contact SMC for details.

Connector manufacturers' example

- HIROSE ELECTRIC CO., LTD.
- 3M Japan Limited
- Fujitsu Limited
- Japan Aviation Electronics Industry, Limited
- J.S.T. Mfg. Co., Ltd.
- Oki Electric Cable Co., Ltd.

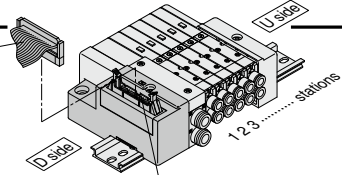

Electrical Wiring Specifications

Flat ribbon cable connector

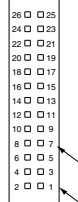

Double wiring (connected to SOL. A and SOL. B) is adopted for the internal wiring of each station, regardless of valve and option types. Mixed single and double wiring is available as an option. For details, refer to page 649.

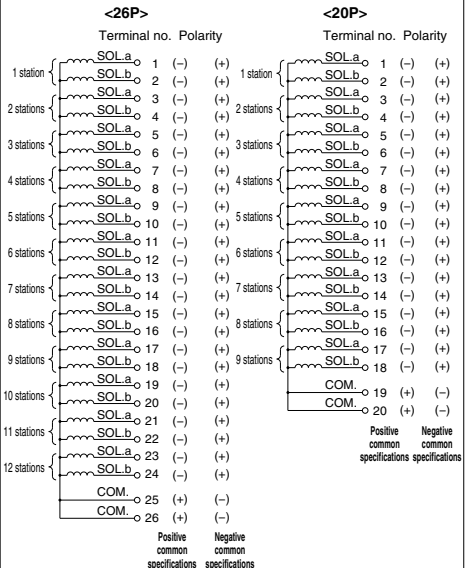

Note) When using the negative common specifications, use valves for negative common.

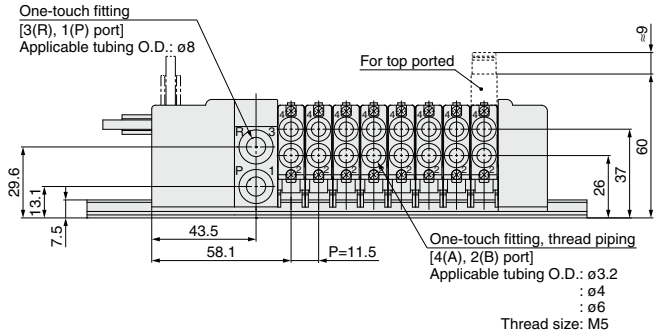
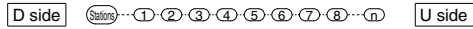
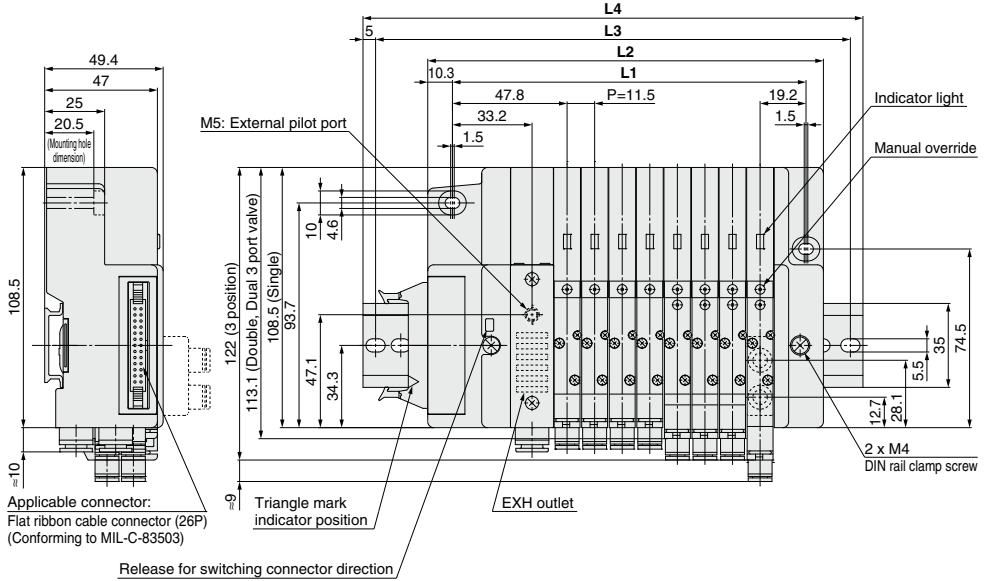

Dimensions

Formula: $L1 = 11.5n + 55.5$, $L2 = 11.5n + 73$ n: Stations (Maximum 24 stations)

L	n	1	2	3	4	5	6	7	8	9	10	11	12	13	14	15	16	17	18	19	20	21	22	23	24
L1		67	78.5	90	101.5	113	124.5	136	147.5	159	170.5	182	193.5	205	216.5	228	239.5	251	262.5	274	285.5	297	308.5	320	331.5
L2		84.5	96	107.5	119	130.5	142	153.5	165	176.5	188	199.5	211	222.5	234	245.5	257	268.5	280	291.5	303	314.5	326	337.5	349
L3		112.5	125	137.5	150	162.5	175	187.5	200	212.5	225	237.5	250	262.5	275	287.5	300	300	312.5	325	337.5	350	362.5	375	
L4		123	135.5	148	160.5	173	185.5	198	210.5	223	235.5	248	260.5	273	285.5	298	310.5	310.5	323	335.5	348	360.5	373	385.5	

SQ1000 Series

L Kit (Lead Wire Cable)

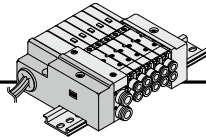

● Direct electrical entry type

Manifold Specifications

Series	Port location	Porting specifications		Maximum number of stations
		1(P), 3(R)	4(A), 2(B)	
SQ1000	Side, Top	C8	C3, C4, C6, M5	12 stations

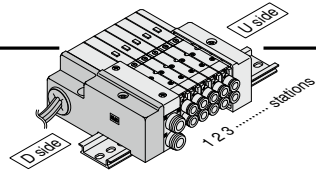

* Valves are numbered from the D side.

● Wiring Specifications: Positive Common Specifications

Three lead wires are included per station regardless of valves used. Among the three lead wires, the red wire is for COM.

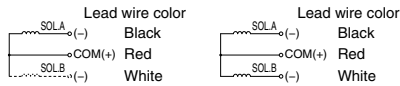

Single solenoid

Double solenoid

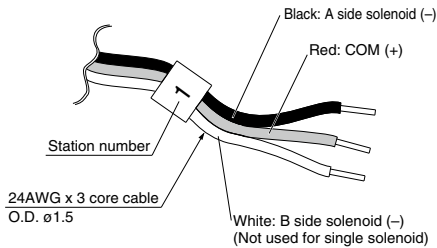

● Wiring Specifications: Negative Common Specifications (Semi-standard)

Three lead wires are included per station regardless of valves used. Among the three lead wires, the black wire is for COM.

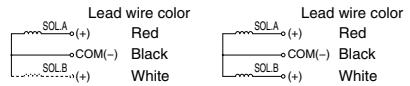

Single solenoid

Double solenoid

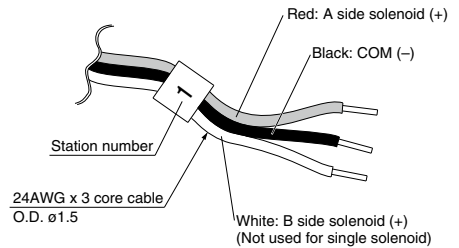

Note) When using the negative common specifications, use valves for negative common.

Negative Common Specifications

The following part numbers are for negative common specifications.

● How to order negative common valves (Example)

SQ1130 N -51-C6

┆ Negative common specifications

● How to order negative common manifold (Example)

SS5Q13-08|LD1N-D|N

┆ Stations

┆ Kit type

┆ Option

┆ DIN rail mounting types

┆ Negative common specifications

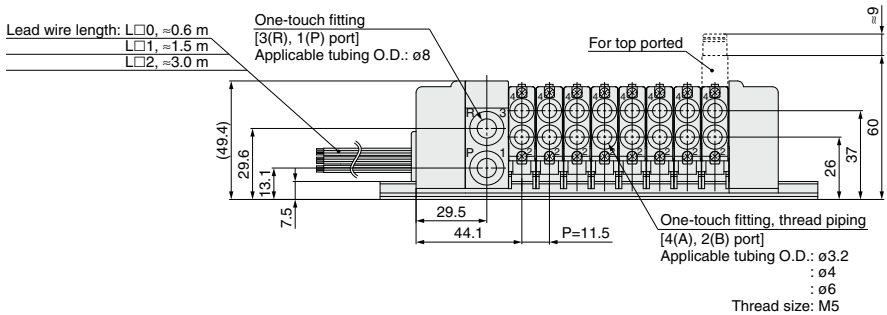
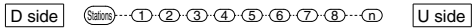
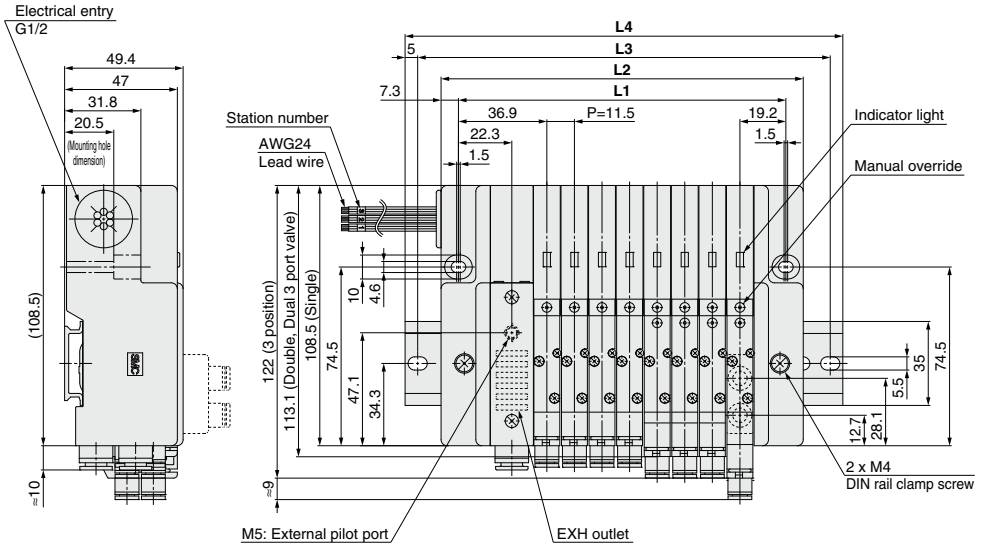

Dimensions Formula: $L1 = 11.5n + 44.5$, $L2 = 11.5n + 59$ n: Stations (Maximum 12 stations)

L	n	1	2	3	4	5	6	7	8	9	10	11	12
L1		56	67.5	79	90.5	102	113.5	125	136.5	148	159.5	171	182.5
L2		70.5	82	93.5	105	116.5	128	139.5	151	162.5	174	185.5	197
L3		100	112.5	125	125	137.5	150	162.5	175	187.5	200	212.5	225
L4		110.5	123	135.5	135.5	148	160.5	173	185.5	198	210.5	223	235.5

SQ1000 Series

S Kit (Serial Transmission Unit) EX140 Integrated-type (For Output) Serial Transmission System

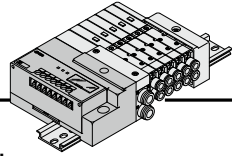

- The serial transmission system reduces wiring work, while minimizing wiring and saving space.
- The maximum number of stations is 8. (16 as a semi-standard). Only for type R2, the maximum stations are 4 (8 as a semi-standard).

Refer to the **Web Catalog** and the Operation Manual for the details of EX140 Integrated-type (For Output) Serial Transmission System.
Please download it via our website, <https://www.smcworld.com>

Manifold Specifications

Series	Porting specifications		Maximum number of stations
	Port location	Port size	
SQ1000	Side, Top	1(P), 3(R)	8 stations (16 as a semi-standard)
		4(A), 2(B)	

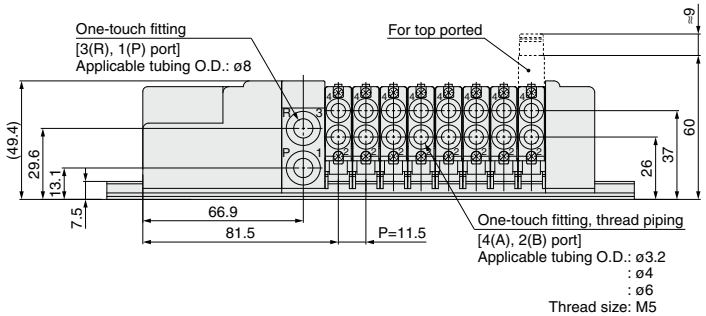
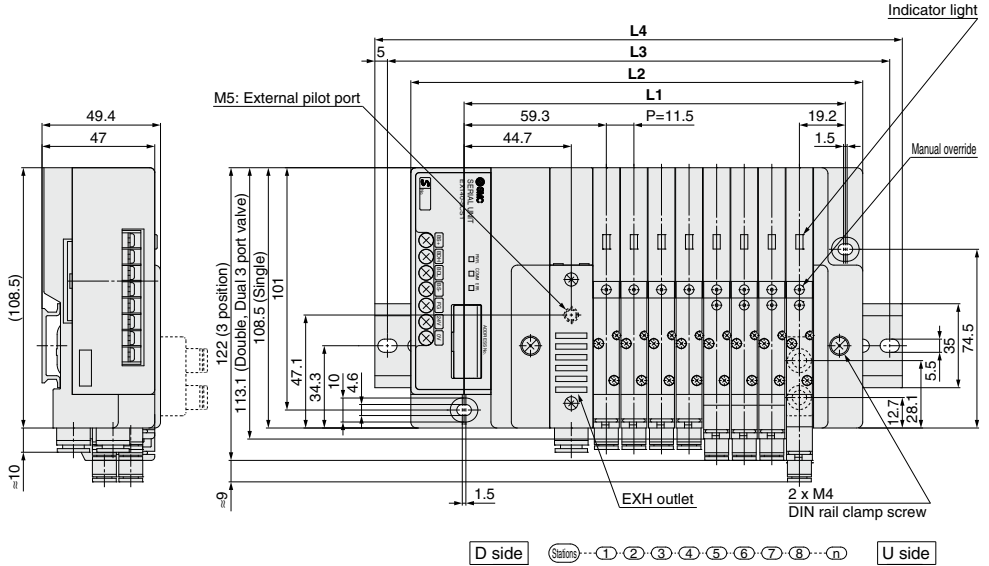

Dimensions

Formula: $L1 = 11.5n + 67$, $L2 = 11.5n + 96.5$ n: Stations (Maximum 16 stations)

L	n	1	2	3	4	5	6	7	8	9	10	11	12	13	14	15	16
L1		78.5	90	101.5	113	124.5	136	147.5	159	170.5	182	193.5	205	216.5	228	239.5	251
L2		108	119.5	131	142.5	154	165.5	177	188.5	200	211.5	223	234.5	246	257.5	269	280.5
L3		137.5	150	162.5	175	187.5	200	212.5	225	237.5	250	262.5	275	287.5	300	300	
L4		148	160.5	173	173	185.5	198	210.5	223	235.5	248	260.5	273	285.5	298	310.5	310.5

EX510 Gateway-type Serial Transmission System Plug-in Unit

SQ2000 Series



How to Order Manifold

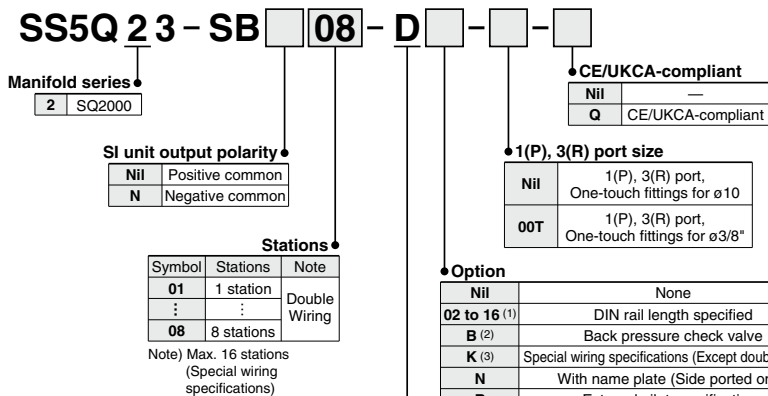

How to Order Manifold

Example

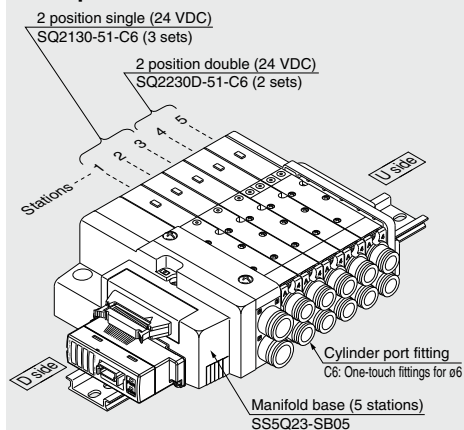

SS5Q23-SB05-D ... 1 set (SB kit 5-station manifold base part no.)
 * SQ2130-51-C6 3 sets (Single type part no.)
 * SQ2230D-51-C6 2 sets (Double type part no.)

→ The asterisk denotes the symbol for assembly.
Prefix it to the part nos. of the solenoid valve, etc.

→ Enter in order starting from the first station on the D side.

Add the valve and option part number under the manifold base part number.
When entry of part numbers becomes complicated, indicate by the manifold specification sheet.

Note 1) Specify DIN rail length with "D□" at the end. (Enter the number of stations inside □.)

The number of stations that may be displayed is longer than the manifold number of stations.
Example: -D09

Note 2) When "-B" is selected, a back pressure check valve is included in all stations of the manifold. If the back pressure check valve is used only for the station that need it, then specify the station location in the manifold specification. ("B" is not necessary)

Note 3) Specify "-K" for wiring specification for cases below.

- All single wiring
- Single and double mixed wiring
- When there are stations which do not require wiring (e.g. single SUP spacer), specify the wiring specification in the manifold specification so that the number of the solenoids is 16 maximum. (Standard wiring specification is double wiring)

Note 4) For specifying two or more options, enter them alphabetically.

Example: -BKN

* Refer to pages 644 to 651 for manifold option parts.

DIN rail mounting

SI Unit Part No.

Symbol	SI unit output polarity	SI unit part no.	Page
Nil	Positive common	EX510-S002B	Web Catalog
N	Negative common	EX510-S102B	

Refer to the **Web Catalog** and the Operation Manual for the details of EX510 Gateway-type Serial Transmission System. Please download it via our website, <https://www.smcworld.com>



How to Order Valves

SQ 2 1 3 0 - **5** - **1** - **C6** - - -

Series
2 SQ2000

Seal
0 Metal seal
1 Rubber seal

CE/UKCA-compliant

Nil	—
Q	CE/UKCA-compliant

• **Type of actuation**

1	2 position single (A)4 2(B) (R1)5 1 3(R2) (P)
2	2 position double (Double solenoid) (1) (A)4 2(B) (A)4 2(B) (R1)5 1 3(R2) (R1)5 1 3(R2) (P) (P) Metal seal Rubber seal
3	3 position closed center (A)4 2(B) (R1)5 1 3(R2) (P)
4	3 position exhaust center (A)4 2(B) (R1)5 1 3(R2) (P)
5	3 position pressure center (A)4 2(B) (R1)5 1 3(R2) (P)
A (2)	4 position dual 3 port valve 4(A) 2(B) 5(R1) 1(P) 3(R2)
B (2)	4 position dual 3 port valve 4(A) 2(B) 5(R1) 1(P) 3(R2)
C (2)	4 position dual 3 port valve 4(A) 2(B) 5(R1) 1(P) 3(R2)

Note 1) For double solenoid specification, the function symbol below is "D".
Note 2) Only rubber seal types are applicable.

• **Function**

Symbol	Specifications
Nil	Standard type (0.4 W)
B	Quick response type (0.95 W)
D (1)	2 position double (Double solenoid specifications)
N (2)	Negative common
R (3)	External pilot specifications

Note 1) "D" is specified for 2 position double.
Note 2) When SI unit output polarity is negative common, the valve common specification should be also be negative common.
Note 3) Except dual 3 port valves.
Note 4) When two or more symbols are specified, indicate them alphabetically.

• **With/Without manifold block**

Nil	M	MB
Without manifold block	With manifold block	With manifold block, built-in back pressure check valve
	* Lead wire is not included.	* Lead wire is not included.
<ul style="list-style-type: none"> When ordering with manifolds When only valves are required. 	For adding stations	

• **Port plug mounting port**

Nil	None
A	Port 4(A)
B	Port 2(B)

• **Cylinder port**

Symbol	Port size	Port location	
C4	One-touch fittings for ø4	Side ported	
C6	One-touch fittings for ø6		
C8	One-touch fittings for ø8	Top (1) ported	
L4	One-touch fittings for ø4		
L6	One-touch fittings for ø6		
L8	One-touch fittings for ø8		

Note 1) Can be changed to side ported configuration.
Note 2) Refer to page 615 for the inch-size One-touch fittings.

• **Manual override**

Nil	B	D
Non-locking push type (Tool required)	Locking type (Tool required)	Slide locking type (Manual type) * Only side ported type applicable

• **Rated voltage**

5 24 VDC

Note) Light/surge voltage suppressor is built-in.

SQ2000 Series

Dimensions: SQ2000

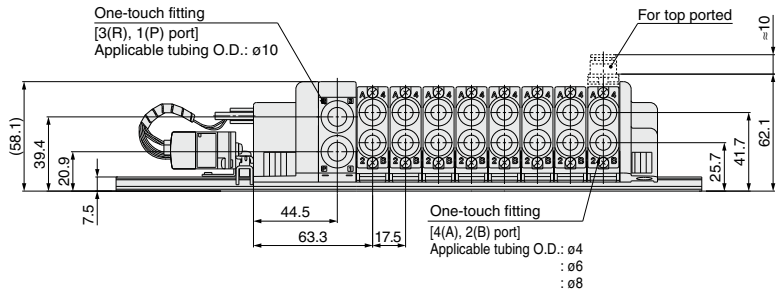
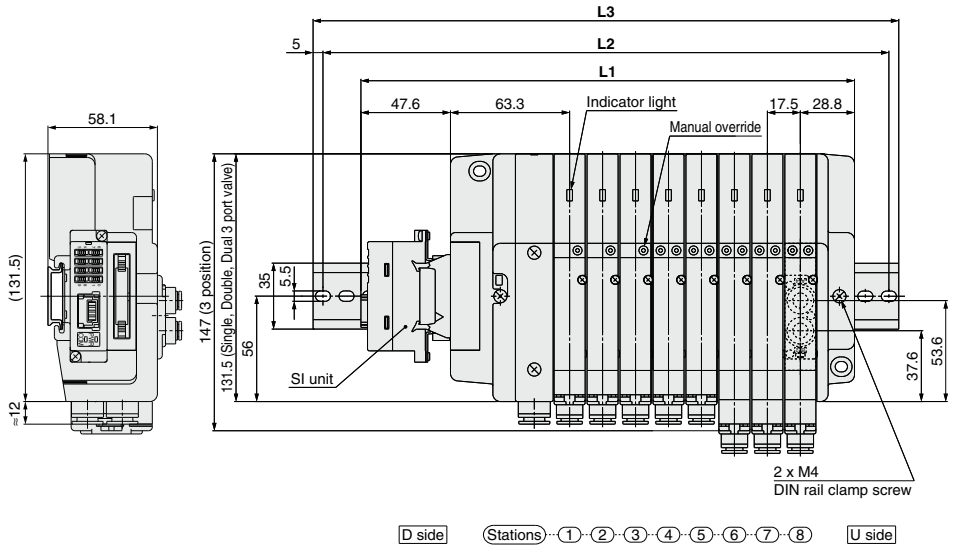

Dimensions

Formula: $L1 = 17.5n + 122$ n: Stations (Maximum 16 stations)

L	n	1	2	3	4	5	6	7	8	9	10	11	12	13	14	15	16
L1		139.5	157	174.5	192	209.5	227	244.5	262	279.5	297	314.5	332	349.5	367	384.5	402
L2		162.5	187.5	200	212.5	237.5	250	275	287.5	300	325	337.5	362.5	375	387.5	412.5	425
L3		173	198	210.5	223	248	260.5	285.5	298	310.5	335.5	348	373	385.5	398	423	435.5

Plug-in Unit

SQ2000 Series



How to Order Manifold

SS5Q23-08 FD2-D

Stations

01	1 station
:	:
16 (Note)	16 stations

Note) The maximum number of stations depends on the type of electrical entries. Refer to "Electrical entry" for details.

1(P), 3(R) port size

Nil	1(P), 3(R) port One-touch fittings for ø10
00T	1(P), 3(R) port One-touch fittings for ø3/8"

CE/UKCA-compliant

Nil	—
Q	CE/UKCA-compliant

Manifold mounting

D	DIN rail mounting type
E (Note)	Direct mounting type

Note) Refer to page 650 for details.

Option

Nil	None
02 to 16 (1)	DIN rail length specified
B (2)	Back pressure check valve
K (3)	Special wiring specifications (Except double wiring)
N	With name plate (Side ported only)
R	External pilot specifications
S	Built-in silencer, direct exhaust

Note 1) Specify DIN rail length with "D□" at the end. (Enter the number of stations inside □.)
The number of stations that may be displayed is longer than the manifold number of stations.
Example: -009

Note 2) When "-B" is selected, a back pressure check valve is included in all stations of the manifold. If the back pressure check valve is used only for the station that need it, then specify the station location in the manifold specification. ("B" is not necessary)

Note 3) Specify "-K" for wiring specification for cases below. (Except L kit)

- All single wiring
- Single and double mixed wiring.
- When there are stations which do not require wiring (e.g. single SUP spacer), specify the wiring specification in the manifold specification so that the number of solenoids is the maximum number of solenoids or less. (Standard wiring specification is double wiring)
Note 4) For specifying two or more options, enter them alphabetically. Example: -BKN
* Refer to pages 644 to 651 for manifold option parts.

Electrical entry

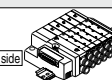
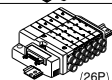
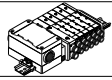
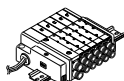
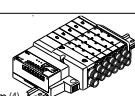
Kit type	Lead wire connector location	Cable/SI unit specifications	Station (Double wiring)	Max. number of stations for special wiring specifications	Max. number of solenoids for special wiring specifications (2)	
F kit  D-sub connector kit	FD0	D side	D-sub connector (25P) kit, without cable	1 to 12 stations	16 stations	
	FD1	D side	D-sub connector (25P) kit, with 1.5 m cable			
	FD2	D side	D-sub connector (25P) kit, with 3.0 m cable			
	FD3	D side	D-sub connector (25P) kit, with 3.0 m cable			
P kit  Flat ribbon cable connector kit (26P)	PD0	D side (1)	Flat ribbon cable (26P) kit, without cable	1 to 12 stations	16 stations	
	PD1		Flat ribbon cable (26P) kit, with 1.5 m cable			
	PD2		Flat ribbon cable (26P) kit, with 3.0 m cable			
	PD3		Flat ribbon cable (26P) kit, with 5.0 m cable			
	PDC		Flat ribbon cable (20P) kit, without cable			1 to 9 stations
T kit  Terminal block box kit	TD0	D side	Terminal block box kit	1 to 10 stations	16 stations	20
L kit Note 3)  Lead wire kit	LD0 (N)	D side	Lead wire kit with 0.6 m cable	1 to 12 stations	—	
	LU0 (N)	U side				
	LD1 (N)	D side				
	LU1 (N)	U side				
	LD2 (N)	D side				
	LU2 (N)	U side				
S kit  Serial transmission kit EX140 Integrated-type (For Output) Serial Transmission System (4)	SDQ	D side	DeviceNet®	1 to 8 stations	16 stations	
	SDR1		OMRON Corp.: CompoBus/S (16 output points)			
	SDR2		OMRON Corp.: CompoBus/S (8 output points)			
	SDV		CC-LINK			1 to 4 stations
				1 to 8 stations	16 stations	16

Note 1) Separately order the 20P type cable assembly for the P Kit.

Note 2) Specify the number of the solenoid so that the maximum station number is not exceeded. (The number of solenoids are counted as: 1 for single solenoids and 2 for type 3P and 4P double solenoids.)

Note 3) When specifying the negative common specifications of the L kit, suffix "N" to the kit symbol. For details, refer to page 636.

Note 4) Refer to the **Web Catalog** and the Operation Manual for the details of EX140 Integrated-type (For Output) Serial Transmission System. Please download it via our website, <https://www.smcworld.com> * Refer to page 663 for manifold spare parts.

SI Unit Part No.

Symbol	Protocol type	SI unit part no.	Page
SDQ	DeviceNet®	EX140-SDN1	Web Catalog
SDR1	OMRON Corp.: CompoBus/S (16 output points)	EX140-SCS1	
SDR2	OMRON Corp.: CompoBus/S (8 output points)	EX140-SCS2	
SDV	CC-LINK	EX140-SMJ1	

How to Order Valves

SQ2 1 3 0 - **5** - **1** - **C6** - - -

Seal

0	Metal seal
1	Rubber seal

CE/UKCA-compliant

Nil	—
Q	CE/UKCA-compliant

Type of actuation

1	2 position single (A)4 2(B) (R1)5 1 3(R2) (P)
2	2 position double (Double solenoid) (1) (A)4 2(B) (A)4 2(B) (R1)5 1 3(R2) (R1)5 1 3(R2) (P) (P) Metal seal Rubber seal
3	3 position closed center (A)4 2(B) (R1)5 1 3(R2) (P)
4	3 position exhaust center (A)4 2(B) (R1)5 1 3(R2) (P)
5	3 position pressure center (A)4 2(B) (R1)5 1 3(R2) (P)
A (2)	4 position dual 3 port valve 4(A) 2(B) 5(R1) 1(P) 3(R2)
B (2)	4 position dual 3 port valve 4(A) 2(B) 5(R1) 1(P) 3(R2)
C (2)	4 position dual 3 port valve 4(A) 2(B) 5(R1) 1(P) 3(R2)

Note 1) For double solenoid specification, the function symbol below is "D".

Note 2) Only rubber seal types are applicable.

Function

Symbol	Specifications
Nil	Standard type (0.4 W)
B	Quick response type (0.95 W)
D (1)	2 position double (Double solenoid specifications)
N (2)	Negative common
R (3)	External pilot specifications

Note 1) "D" is specified for 2 position double.

Note 2) For L kit, when the manifold specifies negative common, the valve common should also be negative. The combination of negative common of the valve cannot be specified with S kit (EX140).

Note 3) Except dual 3 port valves.

Note 4) When two or more symbols are specified, indicate them alphabetically.

With/Without manifold block

Nil	M	MB
Without manifold block 	With manifold block 	With manifold block, built-in back pressure check valve
• When ordering with manifolds • When only valves are required.	* Lead wire is not included.	* Lead wire is not included.
For adding stations		

Port plug mounting port

Nil	None
A	Port 4(A)
B	Port 2(B)

Cylinder port

Symbol	Port size	Port location	
C4	With One-touch fittings for ø4	Side ported 	
C6	With One-touch fittings for ø6		
C8	With One-touch fittings for ø8		
L4	With One-touch fittings for ø4	Top (1) ported 	
L6	With One-touch fittings for ø6		
L8	With One-touch fittings for ø8		

Note 1) Can be changed to side ported configuration.

Note 2) Refer to page 651 for the inch-size One-touch fittings.

Manual override

Nil	B	D
Non-locking push type (Tool required)	Locking type (Tool required)	Slide locking type (Manual type) * Only side ported type applicable

Rated voltage

5	24 VDC
6	12 VDC

Note 1) Light/surge voltage suppressor is built-in.

Note 2) S kit: 24 VDC only

SQ2000 Series

Manifold Options

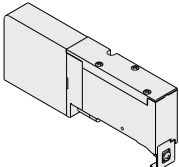
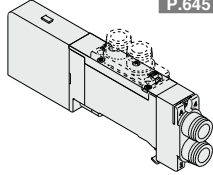
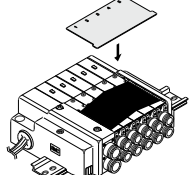
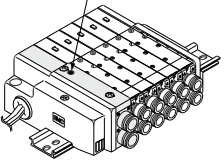
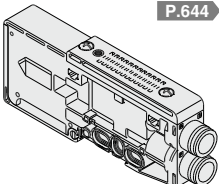
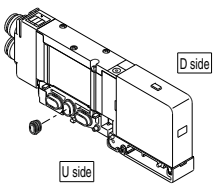
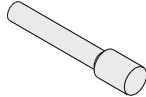
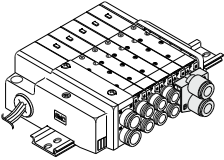
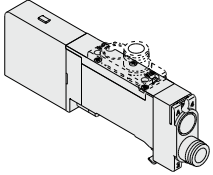
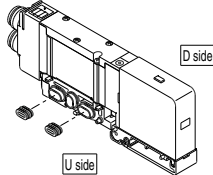
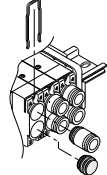
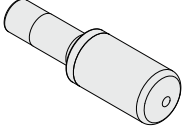
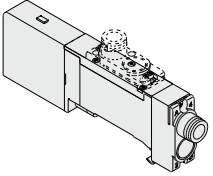
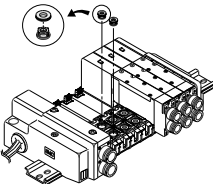
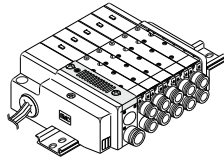
<p>Blanking plate SSQ2000-10A-3 P.644</p> 	<p>Individual SUP/EXH spacer SSQ2000-PR1-3-C⁸_{L⁸} P.645</p> 	<p>Name plate (-N) SSQ2000-N3-n P.647</p> 	<p>External pilot specifications (-R) P.648 External pilot port</p> 																																																																																										
<p>SUP/EXH block SSQ2000-PR-3-C10(-S) P.644</p> 	<p>SUP block plate SSQ1000-B-R P.646</p>  <p>D side U side</p>	<p>Blanking plug KQ2P-04/06/08/10 P.647</p> 	<p>Dual flow fitting SSQ2000-52A-C¹⁰_{N11} P.648</p> 																																																																																										
<p>Individual SUP spacer SSQ2000-P-3-C⁸_{L⁸} P.644</p> 	<p>EXH block plate SSQ2000-B-R P.646</p>  <p>D side U side</p>	<p>Port plug VVQZ2000-CP P.647</p> 	<p>Silencer (For EXH port) P.648</p> 																																																																																										
<p>Individual EXH spacer SSQ2000-R-3-C⁸_{L⁸} P.645</p> 	<p>Back pressure check valve (-B) SSQ2000-BP P.646</p> 	<p>Built-in silencer, direct exhaust (-S) P.647</p> 	<p>Special wiring specifications (-K) P.649</p> <p>D-sub connector</p> <table border="0"> <tr> <td>Terminal no.</td> <td></td> <td></td> </tr> <tr> <td>1 station</td> <td>—</td> <td>SOLA 1 (-)</td> </tr> <tr> <td>2 stations</td> <td>—</td> <td>SOLA 14 (-)</td> </tr> <tr> <td>3 stations</td> <td>—</td> <td>SOLA 2 (-)</td> </tr> <tr> <td>4 stations</td> <td>—</td> <td>SOLA 15 (-)</td> </tr> <tr> <td>5 stations</td> <td>—</td> <td>SOLA 3 (-)</td> </tr> <tr> <td>6 stations</td> <td>—</td> <td>SOLA 16 (-)</td> </tr> <tr> <td>7 stations</td> <td>—</td> <td>SOLA 4 (-)</td> </tr> <tr> <td>8 stations</td> <td>—</td> <td>SOLA 17 (-)</td> </tr> <tr> <td>140</td> <td>01</td> <td>—</td> </tr> <tr> <td>150</td> <td>02</td> <td>—</td> </tr> <tr> <td>160</td> <td>03</td> <td>—</td> </tr> <tr> <td>160</td> <td>04</td> <td>—</td> </tr> <tr> <td>170</td> <td>05</td> <td>—</td> </tr> <tr> <td>180</td> <td>06</td> <td>—</td> </tr> <tr> <td>190</td> <td>07</td> <td>—</td> </tr> <tr> <td>190</td> <td>08</td> <td>—</td> </tr> <tr> <td>200</td> <td>09</td> <td>—</td> </tr> <tr> <td>210</td> <td>09</td> <td>—</td> </tr> <tr> <td>220</td> <td>09</td> <td>—</td> </tr> <tr> <td>230</td> <td>010</td> <td>—</td> </tr> <tr> <td>240</td> <td>011</td> <td>—</td> </tr> <tr> <td>250</td> <td>012</td> <td>—</td> </tr> <tr> <td>250</td> <td>013</td> <td>—</td> </tr> <tr> <td>Connector terminal no.</td> <td></td> <td></td> </tr> <tr> <td></td> <td>—</td> <td>SOLA 5 (-)</td> </tr> <tr> <td></td> <td>—</td> <td>SOLA 18 (-)</td> </tr> <tr> <td></td> <td>—</td> <td>SOLA 6 (-)</td> </tr> <tr> <td></td> <td>—</td> <td>SOLA 19 (-)</td> </tr> <tr> <td></td> <td>—</td> <td>COM. 13 (+)</td> </tr> </table> <p>Although the standard products come with double wiring, mixed single and double wiring is available upon request.</p>	Terminal no.			1 station	—	SOLA 1 (-)	2 stations	—	SOLA 14 (-)	3 stations	—	SOLA 2 (-)	4 stations	—	SOLA 15 (-)	5 stations	—	SOLA 3 (-)	6 stations	—	SOLA 16 (-)	7 stations	—	SOLA 4 (-)	8 stations	—	SOLA 17 (-)	140	01	—	150	02	—	160	03	—	160	04	—	170	05	—	180	06	—	190	07	—	190	08	—	200	09	—	210	09	—	220	09	—	230	010	—	240	011	—	250	012	—	250	013	—	Connector terminal no.				—	SOLA 5 (-)		—	SOLA 18 (-)		—	SOLA 6 (-)		—	SOLA 19 (-)		—	COM. 13 (+)
Terminal no.																																																																																													
1 station	—	SOLA 1 (-)																																																																																											
2 stations	—	SOLA 14 (-)																																																																																											
3 stations	—	SOLA 2 (-)																																																																																											
4 stations	—	SOLA 15 (-)																																																																																											
5 stations	—	SOLA 3 (-)																																																																																											
6 stations	—	SOLA 16 (-)																																																																																											
7 stations	—	SOLA 4 (-)																																																																																											
8 stations	—	SOLA 17 (-)																																																																																											
140	01	—																																																																																											
150	02	—																																																																																											
160	03	—																																																																																											
160	04	—																																																																																											
170	05	—																																																																																											
180	06	—																																																																																											
190	07	—																																																																																											
190	08	—																																																																																											
200	09	—																																																																																											
210	09	—																																																																																											
220	09	—																																																																																											
230	010	—																																																																																											
240	011	—																																																																																											
250	012	—																																																																																											
250	013	—																																																																																											
Connector terminal no.																																																																																													
	—	SOLA 5 (-)																																																																																											
	—	SOLA 18 (-)																																																																																											
	—	SOLA 6 (-)																																																																																											
	—	SOLA 19 (-)																																																																																											
	—	COM. 13 (+)																																																																																											

How to Order Manifold Assembly

Example: D-sub connector kit, with cable (3 m)

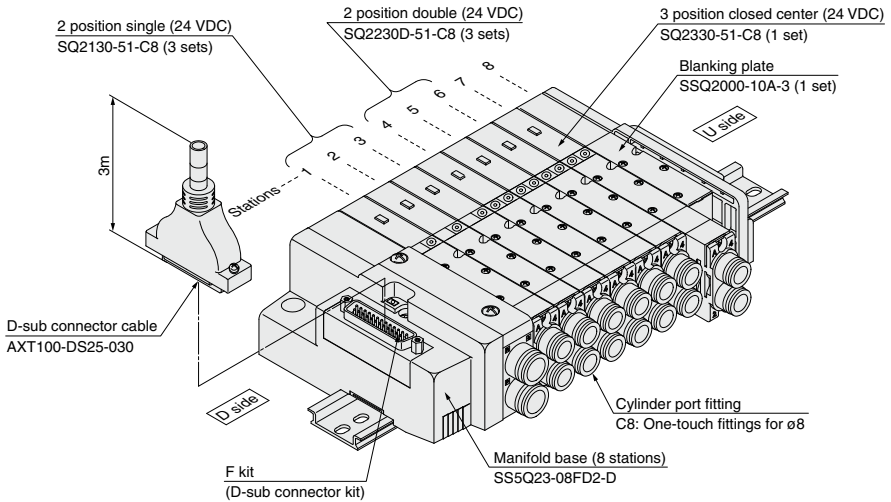

SS5Q23-08FD2-D ... 1 set (F kit 8-station manifold base)

* **SQ2130-51-C8 ... 3 sets (2 position single)**

* **SQ2230D-51-C8 ... 3 sets (2 position double)**

* **SQ2330-51-C8 ... 1 set (3 position closed center)**

* **SSQ2000-10A-3 ... 1 set (Blanking plate)**

↳ The asterisk denotes the symbol for assembly. Prefix it to the part nos. of the solenoid valve, etc.

Add the valve and option part numbers in order starting from the first station on the D side.
When entry of part numbers becomes complicated, indicate on the manifold specification sheet.

SQ2000 Series

Valve Specifications

Model

Series	Type of actuation	Seal	Model	Flow characteristic (1)						Response time (ms) (2)		Weight (g)	
				1→4/2 (P→A/B)			4/2→5/3 (A/B→R1/R2)			Standard (0.4 W)	Quick response (0.95 W)		
				C [dm ³ /(s·bar)]	b	Cv	C [dm ³ /(s·bar)]	b	Cv				
SQ2000	2 position	Single	Metal seal	SQ2130	2.2	0.17	0.51	2.4	0.14	0.57	35 or less	20 or less	145
			Rubber seal	SQ2131	2.3	0.17	0.51	3.1	0.18	0.71	31 or less	24 or less	140
		Double	Metal seal	SQ2230D	2.2	0.17	0.51	2.4	0.14	0.57	20 or less	15 or less	160
			Rubber seal	SQ2231D	2.3	0.17	0.51	3.1	0.18	0.71	26 or less	20 or less	155
	3 position	Closed center	Metal seal	SQ2330	1.9	0.17	0.46	2.1	0.15	0.47	56 or less	37 or less	180
			Rubber seal	SQ2331	1.9	0.17	0.46	1.8	0.29	0.47	44 or less	34 or less	175
		Exhaust center	Metal seal	SQ2430	1.9	0.17	0.46	2.4	0.14	0.55	56 or less	37 or less	180
			Rubber seal	SQ2431	1.9	0.17	0.46	3.1	0.14	0.65	44 or less	34 or less	175
		Pressure center	Metal seal	SQ2530	2.3	0.17	0.51	2.1	0.18	0.47	56 or less	37 or less	180
			Rubber seal	SQ2531	2.5	0.17	0.56	1.8	0.30	0.47	44 or less	34 or less	175
	4 position	Dual 3 port valve	Rubber seal	SQ2631	1.5	0.17	0.40	1.5	0.17	0.40	34 or less	19 or less	155

Note 1) Values for the top ported cylinder port size of C8. CYL → Values of EXH. The side ported type will be about 10% less.

Note 2) Based on JIS B 8419: 2010. (Values with a supply pressure of 0.5 MPa and light/surge voltage suppressor. Values fluctuate depending on the pressure and air quality.)

Specifications

Valve specifications	Valve construction		Metal seal	Rubber seal
	Fluid	Air		
	Maximum operating pressure	0.7 MPa		
	Min. operating pressure	Single	0.1 MPa	0.15 MPa
		Double (Double solenoid)	0.1 MPa	0.1 MPa
		3 position	0.1 MPa	0.2 MPa
		4 position	—	0.15 MPa
	Ambient fluid temperature	-10 to 50°C (1)		
	Lubrication	Not required		
	Pilot valve manual override	Push type (Tool required)/Locking type (Tool required)/Slide locking type (Manual type)		
Vibration/Impact resistance (2)	30/150 m/s ²			
Protection structure	Dust tight			
Solenoid specifications	Coil rated voltage	12 VDC, 24 VDC		
	Allowable voltage fluctuation	±10% of rated voltage		
	Coil insulation type	Equivalent to class B		
	Power consumption (Current)	24 VDC	0.4 W DC (17 mA), 0.95 W DC (40 mA) (3)	
		12 VDC	0.4 W DC (34 mA), 0.95 W DC (80 mA) (3)	

Note 1) Use dry air to prevent condensation when operating at low temperatures.

Note 2) Vibration resistance: No malfunction occurred in a one-sweep test between 45 and 2000 Hz. Test was performed at both energized and de-energized states in the axial direction and at the right angles to the main valve and armature. (Values at the initial period)

Impact resistance: No malfunction occurred when it is tested with a drop tester in the axial direction and at the right angles to the main valve and armature in both energized and de-energized states every once for each condition.

Note 3) Value for quick response type.



Symbol

2 position single

(A)4 2(B)

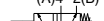

(R1)5 1 3(R2)

(P)

2 position double (Double solenoid)

(A)4 2(B) (A)4 2(B)



(R1)5 1 3(R2) (R1)5 1 3(R2)

(P)

Metal seal Rubber seal

3 position closed center

(A)4 2(B)

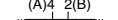

(R1)5 1 3(R2)

(P)

3 position exhaust center

(A)4 2(B)

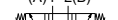

(R1)5 1 3(R2)

(P)

3 position pressure center

(A)4 2(B)

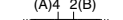

(R1)5 1 3(R2)

(P)

4 position dual 3 port valve (A)

4(A) 2(B)

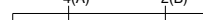

5(R1) 1(P) 3(R2)

4 position dual 3 port valve (B)

4(A) 2(B)

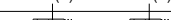

5(R1) 1(P) 3(R2)

4 position dual 3 port valve (C)

4(A) 2(B)

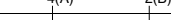

5(R1) 1(P) 3(R2)

Manifold Specifications

Base model	Porting specifications			Applicable solenoid valve	Type of connection	Applicable stations ⁽³⁾ (Double wiring)	5-station weight ⁽⁴⁾ (g)	Addition per station ⁽⁴⁾ (g)		
	Port size ⁽¹⁾		Port location							
	1(P), 3(R)	4(A), 2(B)								
SS5Q23-□□-□	C10 (For ø10) Option Built-in silencer, (direct exhaust)	Side	C4 (For ø4) C6 (For ø6) C8 (For ø8)	SQ2□30 SQ2□31	F kit: D-sub connector	1 to 12 stations	580	35		
			Top ⁽²⁾		L4 (For ø4) L6 (For ø6) L8 (For ø8)	P kit: Flat ribbon cable	26P	1 to 12 stations	580	35
							20P	1 to 9 stations		
					T kit: Terminal block	1 to 10 stations	1,165	620		
					L kit: Lead wire	1 to 12 stations	620	50		
					S kit: Serial transmission	1 to 8 stations	650	35		

Note 1) One-touch fittings in inch sizes are also available. For details, refer to page 651.

Note 2) Can be changed to side ported configuration.

Note 3) An optional specification for special wiring is available to increase the maximum number of stations. Refer to page 649 for details.

Note 4) Except valves. For valve weight, refer to page 628.

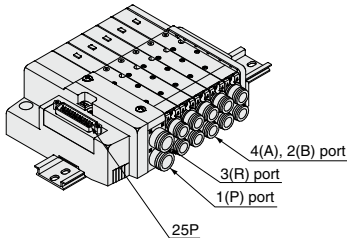

F kit

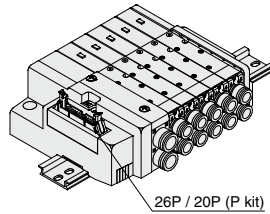

P kit

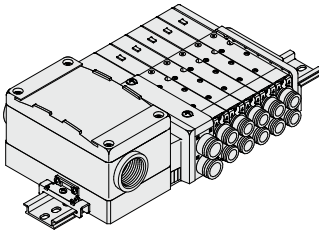

T kit

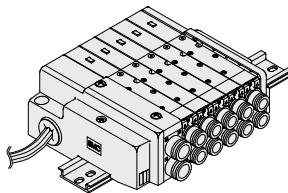

L kit

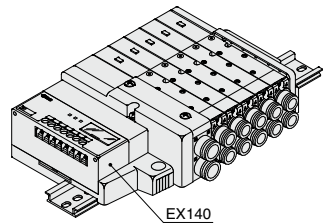

S kit

Refer to the **Web Catalog** and the Operation Manual for the details of EX140 Integrated-type (For Output) Serial Transmission System. Please download it via our website, <https://www.smcworld.com>

SQ2000 Series

F Kit (D-sub Connector Kit)

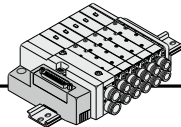

- Simplification and labor savings for wiring work can be achieved by using a D-sub connector for the electrical connection.
- Using connector for flat ribbon cable (25P) conforming to MIL standard permits the use of connectors put on the market and gives a wide interchangeability.
- Top or side entry for the connector can be changed freely, allowing later changes according to the mounting space.

Manifold Specifications

Series	Porting specifications			Maximum number of stations
	Port location	Port size		
SQ2000	Side, Top	1(P), 3(R)	4(A), 2(B)	12 stations (16 as a semi-standard)

D-sub Connector (25 Pin)

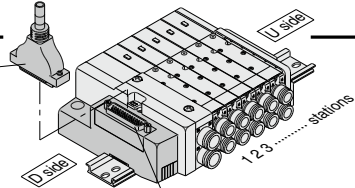

Cable Assembly ●

015
AXT100-DS25-030
050

(D-sub connector cable assemblies can be ordered with manifolds.)
Refer to manifold ordering.

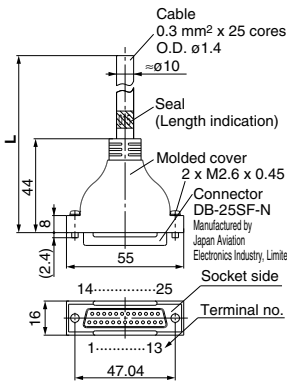

D-sub Connector Cable Assembly Terminal No.

Terminal number	Lead wire color	Dot marking
1	Black	None
2	Brown	None
3	Red	None
4	Orange	None
5	Yellow	None
6	Pink	None
7	Blue	None
8	Purple	White
9	Gray	Black
10	White	Black
11	White	Red
12	Yellow	Red
13	Orange	Red
14	Yellow	Black
15	Pink	Black
16	Blue	White
17	Purple	None
18	Gray	None
19	Orange	Black
20	Red	White
21	Brown	White
22	Pink	Red
23	Gray	Red
24	Black	White
25	White	None

D-sub Connector Cable Assembly

Cable length (L)	Assembly part no.	Note
1.5 m	AXT100-DS25-015	Cable
3 m	AXT100-DS25-030	0.3 mm ² x 25 cores
5 m	AXT100-DS25-050	25 cores

* For other commercial connectors, use a 25 pins type with female connector conforming to MIL-C-24308.

* Cannot be used for transfer wiring.

* Lengths other than the above are also available. Please contact SMC for details.

Electric Characteristics

Item	Characteristics
Conductor resistance Ω/km, 20°C	65 or less
Withstand voltage VAC, 1 min.	1000
Insulation resistance MΩ/km, 20°C	5 or more

Note) The minimum bending radius for D-sub connector cable is 20 mm.

Connector manufacturers' example

- Fujitsu Limited
- Japan Aviation Electronics Industry, Limited
- J.S.T. Mfg. Co., Ltd.
- HIROSE ELECTRIC CO., LTD.

Electrical Wiring Specifications ●

D-sub connector

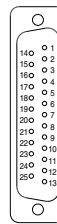

Connector terminal no.

As the standard electrical wiring specifications, double wiring (connected to SOL. A and SOL. B) is adopted for the internal wiring of each station for 12 stations or less, regardless of valve and option types.

Mixed single and double wiring is available as an option.

For details, refer to page 649.

Lead wire colors for D-sub connector assembly (AXT100-DS25-015 to 050)

	Terminal no.	Polarity	Lead wire color	Dot marking	
1 station	SOL _a 1	(-)	(+)	Black	None
	SOL _b 14	(-)	(+)	Yellow	Black
2 stations	SOL _a 2	(-)	(+)	Brown	None
	SOL _b 15	(-)	(+)	Pink	Black
3 stations	SOL _a 3	(-)	(+)	Red	None
	SOL _b 16	(-)	(+)	Blue	White
4 stations	SOL _a 4	(-)	(+)	Orange	None
	SOL _b 17	(-)	(+)	Purple	None
5 stations	SOL _a 5	(-)	(+)	Yellow	None
	SOL _b 18	(-)	(+)	Gray	None
6 stations	SOL _a 6	(-)	(+)	Pink	None
	SOL _b 19	(-)	(+)	Orange	Black
7 stations	SOL _a 7	(-)	(+)	Blue	None
	SOL _b 20	(-)	(+)	Red	White
8 stations	SOL _a 8	(-)	(+)	Purple	White
	SOL _b 21	(-)	(+)	Brown	White
9 stations	SOL _a 9	(-)	(+)	Gray	Black
	SOL _b 22	(-)	(+)	Pink	Red
10 stations	SOL _a 10	(-)	(+)	White	Black
	SOL _b 23	(-)	(+)	Gray	Red
11 stations	SOL _a 11	(-)	(+)	White	Red
	SOL _b 24	(-)	(+)	Black	White
12 stations	SOL _a 12	(-)	(+)	Yellow	Red
	SOL _b 25	(-)	(+)	White	None
	COM.	(+)	(-)	Orange	Red

Positive common specifications Negative common specifications

Note) When using the negative common specifications, use valves for negative common.

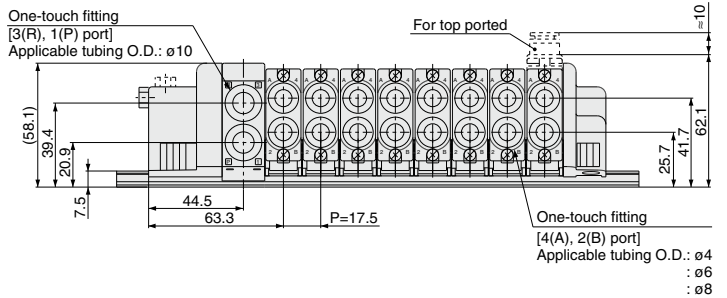
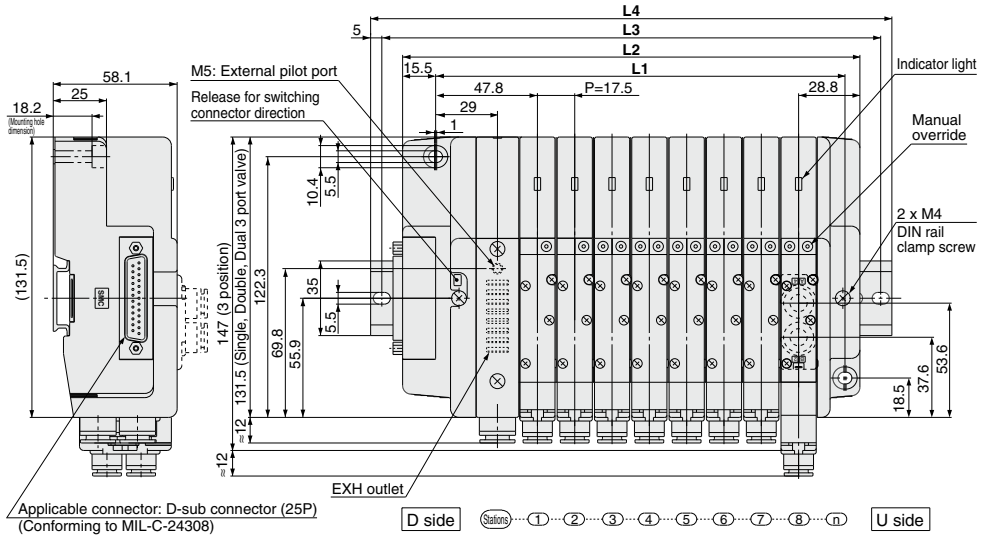

Dimensions

Formula: $L1 = 17.5n + 52$, $L2 = 17.5n + 74.5$ n: Stations (Maximum 16 stations)

L	n	1	2	3	4	5	6	7	8	9	10	11	12	13	14	15	16
L1		69.5	87	104.5	122	139.5	157	174.5	192	209.5	227	244.5	262	279.5	297	314.5	332
L2		92	109.5	127	144.5	162	179.5	197	214.5	232	249.5	267	284.5	302	319.5	337	354.5
L3		112.5	137.5	150	175	187.5	200	225	237.5	262.5	275	287.5	312.5	325	350	362.5	375
L4		123	148	160.5	185.5	198	210.5	235.5	248	273	285.5	298	323	335.5	360.5	373	385.5

SQ2000 Series

P Kit (Flat Ribbon Cable Connector)

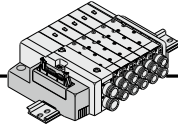

- Flat ribbon cable connector reduces installation labor for electrical connection.
- Using the connector for flat ribbon cable (26P, 20P) conforming to MIL standard permits the use of connectors put on the market and gives a wide interchangeability.
- Top or side receptacle position can be selected in accordance with the available mounting space.

Manifold Specifications

Series	Porting specifications		Maximum number of stations
	Port location	Port size	
SQ2000	Side, Top	1(P), 3(R)	12 stations (16 as a semi-standard)
		4(A), 2(B)	

Flat Ribbon Cable (26 Pins, 20 Pins)

AXT100-FC $\begin{matrix} 20 \\ 26 \\ 2 \\ 3 \end{matrix}$

(Type 26P flat ribbon cable connector assemblies can be ordered with manifolds. Refer to "How to Order manifold".)

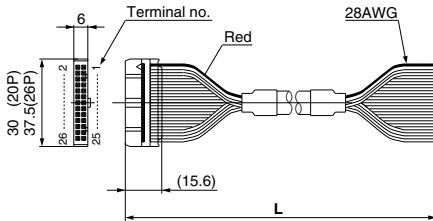

Flat Ribbon Cable Connector Assembly

Cable length (L)	Assembly part no.	
	26P	20P
1.5 m	AXT100-FC26-1	AXT100-FC20-1
3 m	AXT100-FC26-2	AXT100-FC20-2
5 m	AXT100-FC26-3	AXT100-FC20-3

- * For other commercial connectors, use a 26 pins or 20 pins with strain relief conforming to MIL-C-83503.
- * Cannot be used for movable wiring.
- * Lengths other than the above are also available. Please contact SMC for details.

Connector manufacturers' example

- HIROSE ELECTRIC CO., LTD.
- 3M Japan Limited
- Fujitsu Limited
- Japan Aviation Electronics Industry, Limited
- J.S.T. Mfg. Co., Ltd.
- Oki Electric Cable Co., Ltd.

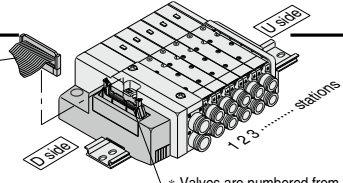

* Valves are numbered from the D side.

Electrical Wiring Specifications

Flat ribbon cable connector

Double wiring (connected to SOL. A and SOL. B) is adopted for the internal wiring of each station, regardless of valve and option types. Mixed single and double wiring is available as an option. For details, refer to page 649.

Connector terminal no.

Triangle mark indicator position

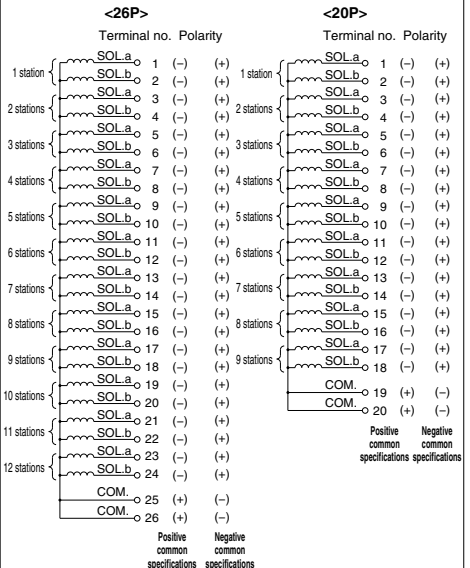

Note) When using the negative common specifications, use valves for negative common.

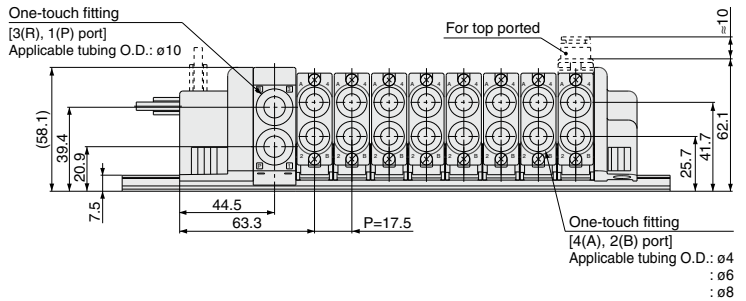
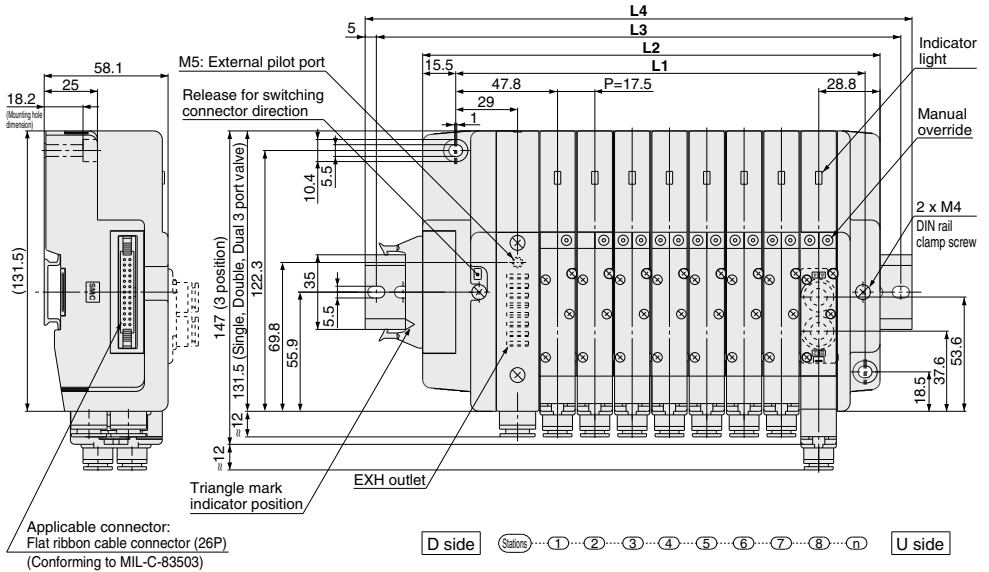

Dimensions

Formula: $L1 = 17.5n + 52$, $L2 = 17.5n + 74.5$ n: Stations (Maximum 16 stations)

L	n	1	2	3	4	5	6	7	8	9	10	11	12	13	14	15	16
L1		69.5	87	104.5	122	139.5	157	174.5	192	209.5	227	244.5	262	279.5	297	314.5	332
L2		92	109.5	127	144.5	162	179.5	197	214.5	232	249.5	267	284.5	302	319.5	337	354.5
L3		112.5	137.5	150	175	187.5	200	225	237.5	262.5	275	287.5	312.5	325	350	362.5	375
L4		123	148	160.5	185.5	198	210.5	235.5	248	273	285.5	298	323	335.5	360.5	373	385.5

SQ2000 Series

T Kit (Terminal Block Box Kit)

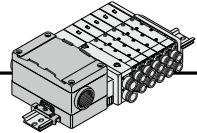

- This kit has a small terminal box inside a junction box. The electrical entry port (G3/4) permits connection of conduit fittings.
- The maximum number of stations is 10 (16 as a semi-standard).

Manifold Specifications

Series	Porting specifications		Maximum number of stations
	Port location	Port size	
SQ2000	Side, Top	1(P), 3(R)	10 stations (16 as a semi-standard)
		4(A), 2(B)	

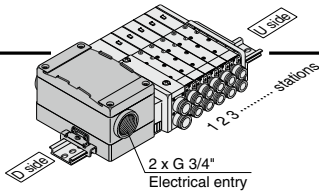

* Valves are numbered from the D side.

Electrical Wiring Specifications

As the standard electrical wiring specifications, double wiring (connected to SOL. A and SOL. B) is adopted for the internal wiring of each station for 10 stations or less, regardless of valve and option types. Mixed single and double wiring is available as an option. For details, refer to page 649.

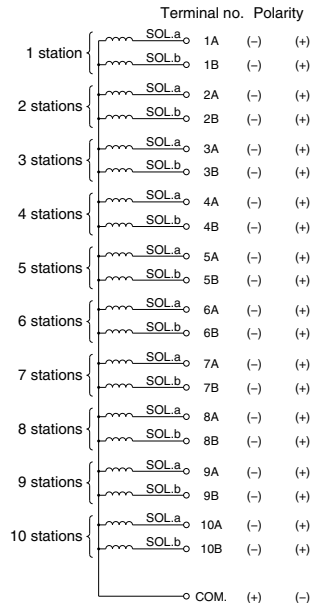
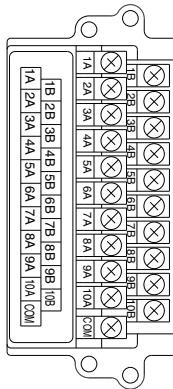

Note) When using the negative common specifications, use valves for negative common.

Positive common specifications Negative common specifications

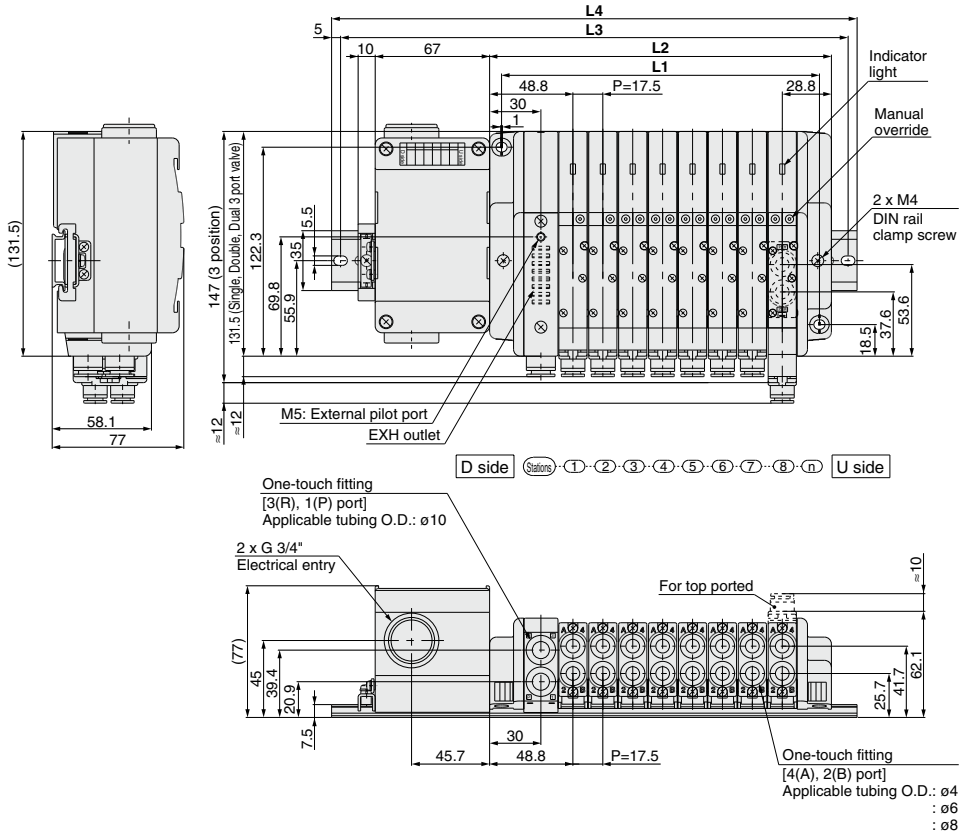

Dimensions

Formula: $L1 = 17.5n + 46$, $L2 = 17.5n + 60$ n: Stations (Maximum 16 stations)

L	n	1	2	3	4	5	6	7	8	9	10	11	12	13	14	15	16
L1		63.5	81	98.5	116	133.5	151	168.5	186	203.5	221	238.5	256	273.5	291	308.5	326
L2		77.5	95	112.5	130	147.5	165	182.5	200	217.5	235	252.5	270	287.5	305	322.5	340
L3		175	200	212.5	237.5	250	262.5	287.5	300	325	337.5	350	375	387.5	412.5	425	437.5
L4	DIN rail mounting	185.5	210.5	223	248	260.5	273	298	310.5	335.5	348	360.5	385.5	398	423	435.5	448
	Direct mounting	160.5	173.0	198.0	210.5	235.5	248.0	260.5	285.5	298.0	323.0	335.5	348.0	373.0	385.5	410.5	423.0

SQ2000 Series

L Kit (Lead Wire Cable)

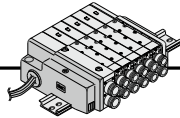

● Direct electrical entry type

Manifold Specifications

Series	Porting specifications		Maximum number of stations
	Port location	Port size	
SQ2000	Side, Top	1(P), 3(R)	4(A), 2(B)
		C10	C4, C6, C8

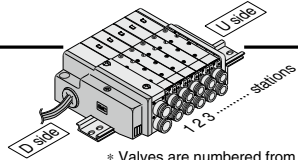

* Valves are numbered from the D side.

● Wiring Specifications: Positive Common Specifications

Three lead wires are included per station regardless of valves used. Among the three lead wires, the red wire is for COM.

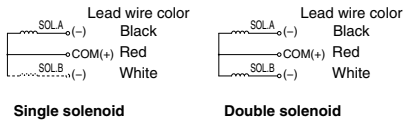

Single solenoid

Double solenoid

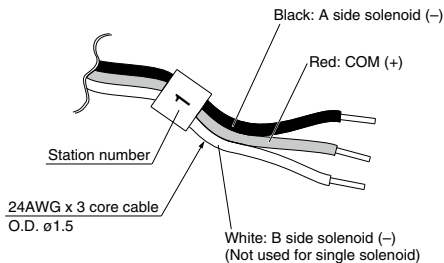

● Wiring Specifications: Negative Common Specifications (Semi-standard)

Three lead wires are included per station regardless of valves used. Among the three lead wires, the black wire is for COM.

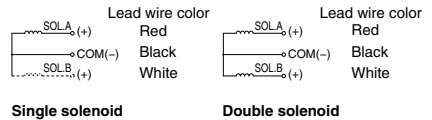

Single solenoid

Double solenoid

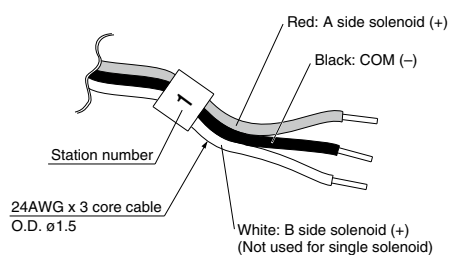

Note) When using the negative common specifications, use valves for negative common.

Negative Common Specifications

The following part numbers are for negative common specifications.

● How to order negative common valves (Example)

SQ2130 N -51-C6

↓ Negative common specifications

● How to order negative common manifold (Example)

SS5Q23-08|LD1N-D|N

Stations ↓

Kit type ↓

↓ Negative common specifications

Option ↓

DIN rail mounting type ↓

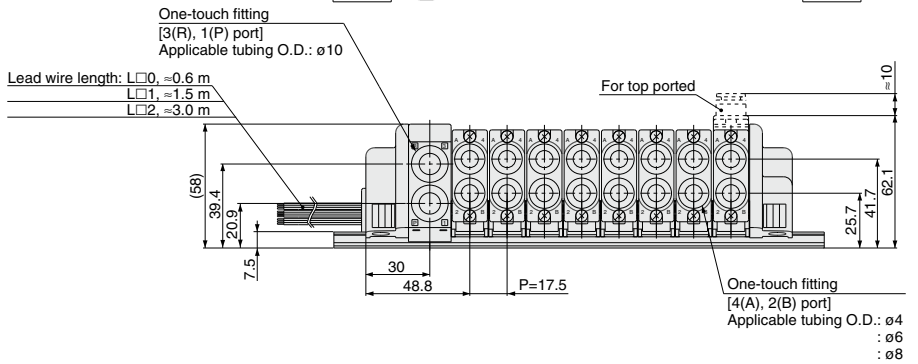
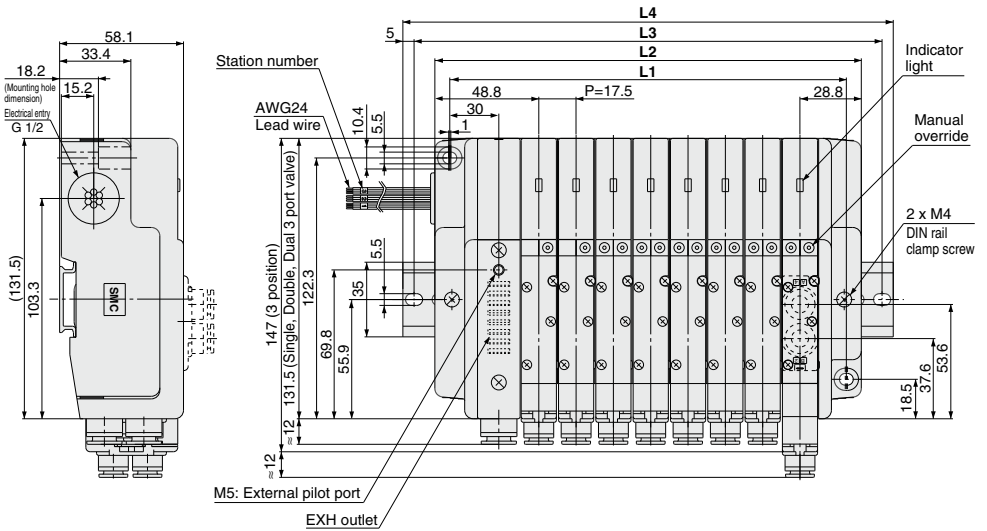

Dimensions Formula: $L1 = 17.5n + 46$, $L2 = 17.5n + 60$ n: Stations (Maximum 12 stations)

L	n	1	2	3	4	5	6	7	8	9	10	11	12
L1		63.5	81	98.5	116	133.5	151	168.5	186	203.5	221	238.5	256
L2		77.5	95	112.5	130	147.5	165	182.5	200	217.5	235	252.5	270
L3		100	125	137.5	150	175	187.5	212.5	225	237.5	262.5	275	300
L4		110.5	135.5	148	160.5	185.5	198	223	235.5	248	273	285.5	310.5

SQ2000 Series

S Kit (Serial Transmission Unit) EX140 Integrated-type (For Output) Serial Transmission System

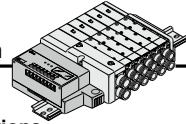

- The serial transmission system reduces wiring work, while minimizing wiring and saving space.
- The maximum number of stations is 8. (16 as a semi-standard). Only for type R2, the maximum stations are 4 (8 as a semi-standard).

Refer to the **Web Catalog** and the Operation Manual for the details of EX140 Integrated-type (For Output) Serial Transmission System.
Please download it via our website, <https://www.smcworld.com>

Manifold Specifications

Series	Porting specifications		Maximum number of stations
	Port location	Port size	
SQ2000	Side, Top	1(P), 3(R)	8 stations (16 as a semi-standard)
		4(A), 2(B)	

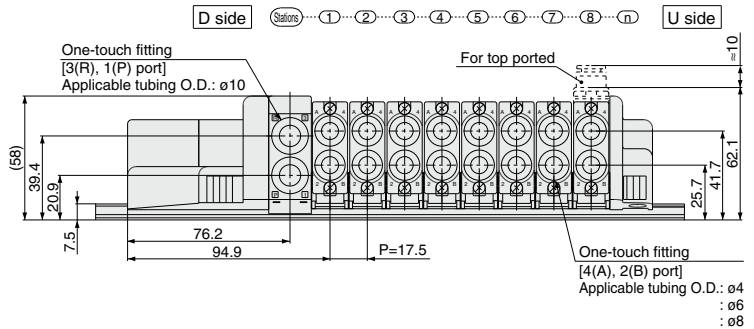
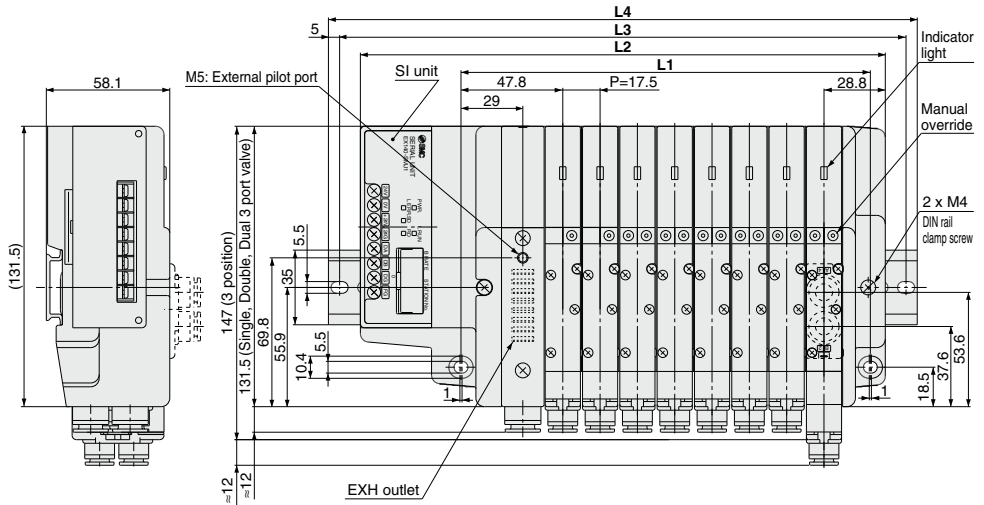

Dimensions

Formula: $L1 = 17.5n + 52$, $L2 = 17.5n + 106$ n: Stations (Maximum 16 stations)

L	n	1	2	3	4	5	6	7	8	9	10	11	12	13	14	15	16
L1		69.5	87	104.5	122	139.5	157	174.5	192	209.5	227	244.5	262	279.5	297	314.5	332
L2		123.5	141	158.5	176	193.5	211	228.5	246	263.5	281	298.5	316	333.5	351	368.5	386
L3		150	162.5	187.5	200	225	237.5	250	275	287.5	312.5	325	337.5	362.5	375	400	412.5
L4		160.5	173	198	210.5	235.5	248	260.5	285.5	298	323	335.5	348	373	385.5	410.5	423

Manifold Option Parts for SQ1000

Blanking plate

SSQ1000-10A-3

It is used by attaching on the manifold block for being prepared for removing a valve for maintenance reasons or planning to mount a spare valve, etc.

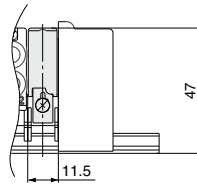
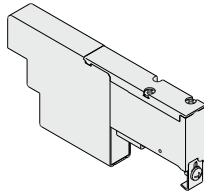

Symbol



SUP/EXH block

SSQ1000-PR-3-C8-□

Port size

C8	One-touch fittings for ø8
N9	One-touch fittings for ø5/16"

Option

NII	Standard
R	External pilot specifications
S	Built-in silencer

Note) When specifying both options, indicate "RS".

* Specify the spacer mounting position on the manifold specification sheet.

For standard type manifolds, the SUP/EXH block is mounted on the D side.

It is added to the manifold to increase SUP/EXH capacity.

* The number of SUP/EXH blocks that can be added is limited to two sets, one between manifold stations and another on the U side of the manifold due to the length of the internal lead wire.

* SUP/EXH blocks are not included in the number of manifold stations.

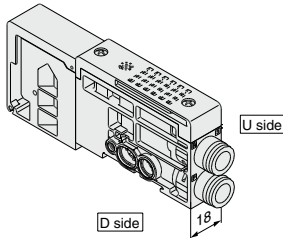

Description/Model	Stations				
	1	2	3	4	5
Valve	●	●	●		
Option				●	

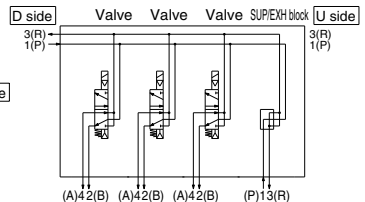

Individual SUP spacer

SSQ1000-P-3-C6

Port size

Side ported	C6	One-touch fittings for ø6
Top ported	N7	One-touch fittings for ø1/4"
Top ported	L6	One-touch fittings for ø6
ported	LN7	One-touch fittings for ø1/4"

This is used as a supply port for different pressures when using different pressures in the same manifold (for one station). Both sides of the station which is used with supply pressure from the individual SUP spacer are shut off. (Refer to application example.)

* Specify the spacer mounting position and SUP passage shut off positions on the manifold specification sheet. Up to two shut off positions can be specified per unit.

(Two pieces of SUP block plate that shut off the supply pressure are included with the individual SUP spacer, therefore, it is not necessary to order them separately.)

* Electrical wiring is also connected to the manifold station with the individual EXH spacer.

* By changing the fitting shown in the drawing and the block plates, the spacer's specification can be changed later (from the individual SUP spacer to the individual EXH spacer).

* The number of spacers is not limited when ordered with the manifold. However, when adding individual SUP spacers later, it is limited to two units, and another on the U side due to the length of the internal lead wire.

* Part number with manifold block:

SSQ1000-P-3-C6-M

Side ported

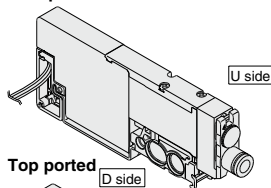

Top ported

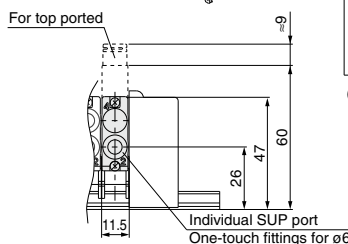
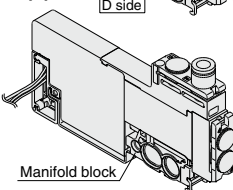

Description/Model	Stations				
	1	2	3	4	5
Valve		●	●		
Option		●	●		

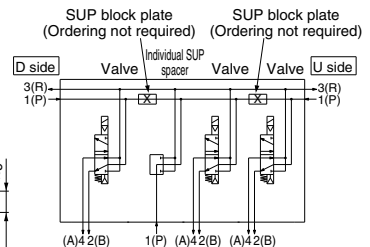

SQ1000 Series

Manifold Option Parts for SQ1000

Individual EXH spacer

SSQ1000-R-3-C6

Port size

Side ported	C6	One-touch fittings for $\phi 6$
	N7	One-touch fittings for $\phi 1/4"$
Top ported	L6	One-touch fittings for $\phi 6$
	LN7	One-touch fittings for $\phi 1/4"$

This is used to exhaust an individual valve when the exhaust from a valve interferes with other stations in the circuit (used for one station).

Both sides of the station which is to be individually exhausted are shut off. (Refer to application example.)

* Specify the spacer mounting position and EXH passage shut off positions on the manifold specification sheet. Up to two shut off positions can be specified per unit.

(Two pieces of EXH block plate that shut off the exhaust are included with the individual EXH spacer, therefore, it is not necessary to order them separately.)

* Electrical wiring is also connected to the manifold station with the individual EXH spacer.

* By changing the fitting shown in the drawing and the block plates, the spacer's specification can be changed later (from the individual EXH spacer to the individual SUP spacer).

* The number of spacers is not limited when ordered with the manifold. However, when adding individual EXH spacers later, it is limited to two units, one between manifold stations and another on the U side due to the length of the internal lead wire.

* Model no. with manifold block:

SSQ1000-R-3-C6-M

Side ported

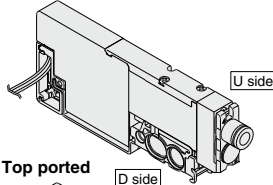

Top ported

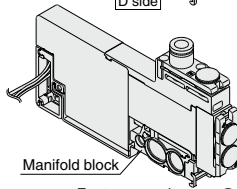

For top ported

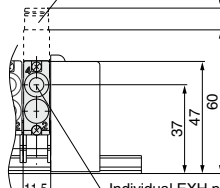

Individual EXH port
One-touch fittings for $\phi 6$

Description/Model	Stations				
	1	2	3	4	5
Valve	Single				
Option	Individual EXH spacer SSQ1000-R-3- <u>C6</u>				
EXH shut off position:	Please specify.				

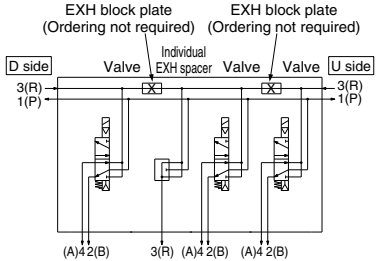

Individual SUP/EXH spacer

SSQ1000-PR1-3-C6

Port size

Side ported	C6	One-touch fittings for $\phi 6$
	N7	One-touch fittings for $\phi 1/4"$
Top ported	L6	One-touch fittings for $\phi 6$
	LN7	One-touch fittings for $\phi 1/4"$

This has both functions of the individual SUP and EXH spacers above. (Refer to application example.)

* Specify the spacer mounting position and SUP and EXH passage shut off positions on the manifold specification sheet. Up to two shut off positions each for SUP and EXH can be specified per unit. (Two pieces each of block plate that shut off the SUP and EXH passages are included with the individual SUP/EXH spacer, therefore, it is not necessary to order them separately.)

* Electrical wiring is also connected to the manifold station with the individual SUP/EXH spacer.

* By changing the fitting shown in the drawing and the block plates, the spacer's specification can be changed later.

* The number of spacers is not limited when ordered with the manifold. However, when adding individual SUP/EXH spacers later, it is limited to two units, one between manifold stations and another on the U side due to the length of the internal lead wire.

* Model no. with manifold block:

SSQ1000-PR1-3-C6-M

* Do not install any back pressure check valve on the manifold station, on which the spacer is to be mounted. When installing the back pressure check valve on other manifold station, be sure to specify the manifold station position on the manifold specification sheet instead of ordering by specifying the manifold option symbol "B".

Side ported

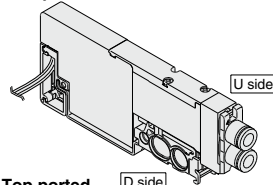

Top ported

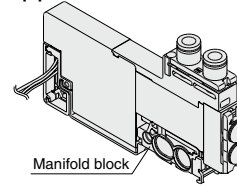

For top ported

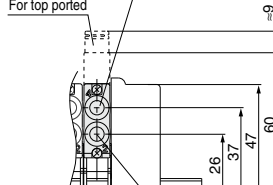

Individual SUP port
One-touch fittings for $\phi 6$

Description/Model	Stations				
	1	2	3	4	5
Valve	Single				
Option	Individual SUP/EXH spacer SSQ1000-PR1-3- <u>C6</u>				
SUP shut off position:	Please specify.				
EXH shut off position:	Please specify.				

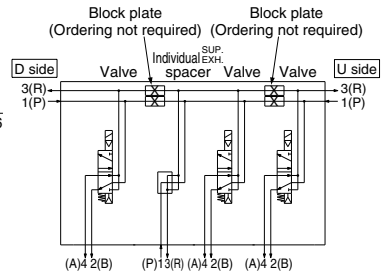

Manifold Option Parts for SQ1000

SUP block plate

SSQ1000-B-P

When supplying two different pressures, high and low, to one manifold, this is used between stations with different pressures. Also, it is used with an individual SUP spacer to shut off the air supply.

* Specify the station position on the manifold specification sheet.

<Block indication label>

When using block plates for SUP passage, indication label for confirmation of the blocking position from outside is attached. (One label of each)

* When ordering a block plate for SUP incorporated with the manifold, a block indication label is attached to the manifold.

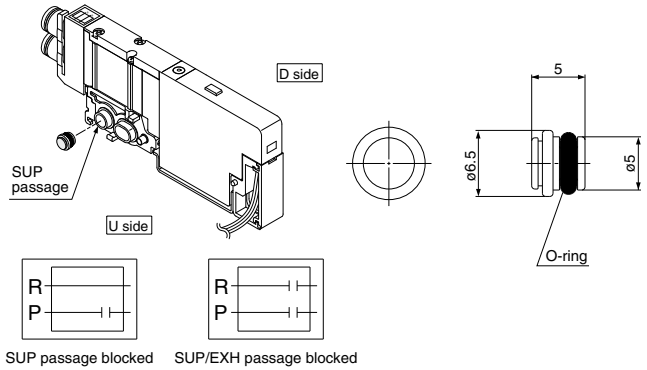

EXH block plate

SSQ1000-B-R

When the exhaust from a valve interferes with other stations in the circuit, this is used between stations to separate exhausts. Also, it is used with an individual EXH spacer to shut off the exhaust of individual valves.

* Specify the station position on the manifold specification sheet.

* Be sure to discharge the exhaust inside the EXH passage from the R port of the SUP/EXH block, etc. so that the exhaust pressure is not sealed.

<Block indication label>

When using block plates for EXH passage, indication label for confirmation of the blocking position from outside is attached. (One label of each)

* When ordering a block plate for EXH incorporated with the manifold, a block indication label is attached to the manifold.

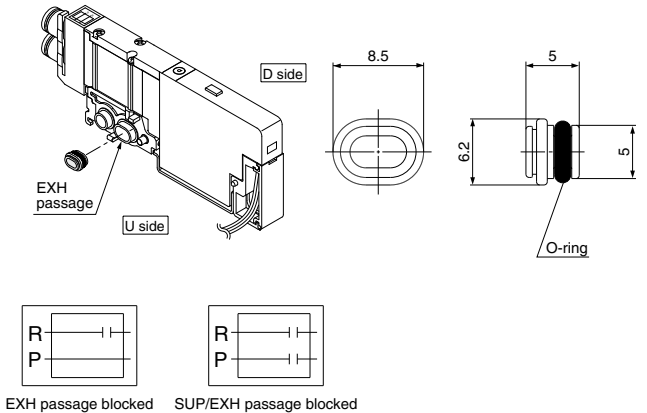

Back pressure check valve [-B]

SSQ1000-BP

It prevents cylinder malfunction caused by other valve exhaust. Insert it into R (EXH) port on the manifold side of a valve which is affected. It is effective when a single action cylinder is used or an exhaust center type solenoid valve is used.

* When a check valve for back pressure prevention is desired, and is to be installed only in certain manifold stations, clearly write the part number and specify the number of stations on the manifold specification sheet.

* When ordering this option incorporated with a manifold, suffix "-B" to the end of the manifold part number.

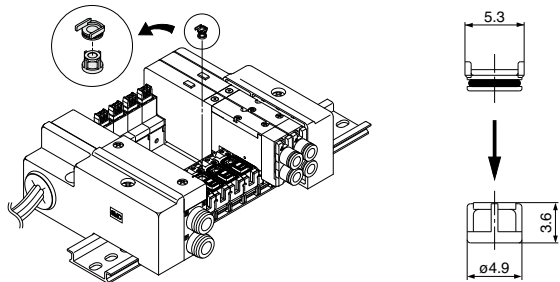

⚠ Caution

1. The manifold installed type back pressure check valve assembly is assembly parts with a check valve structure. However, since slight air leakage against the back pressure is allowed due to its structure, adverse effects of the back pressure due to increase in exhaust resistance cannot be prevented if the manifold exhaust port and other exhaust ports are put together for piping or if the piping diameter is narrowed. As a result, this may cause the actuator and air operated equipment to malfunction. So, be careful not to restrict the exhaust air. If the exhaust resistance becomes large, select a built-in valve type with rubber seal.
2. When a back pressure check valve is mounted, the effective area of the valve will decrease by about 20%.
3. Since 4 port specification valves (5 (R1) and 3 (R2) are common) are used, back pressure cannot be prevented with dual 3 port valves.

SQ1000 Series

Manifold Option Parts for SQ1000

Name plate [-N]

SSQ1000-N3-Stations (1 to maximum)

It is a transparent resin plate for placing a label that indicates solenoid valve function, etc.

Insert it into the groove on the side of the end plate and bend it as shown in the figure. Also, the plate is difficult to bend for manifolds with only a few stations, therefore, remove the silencer cover to install it.

* When ordering this option incorporated with a manifold, suffix "-N" to the end of the manifold part number.

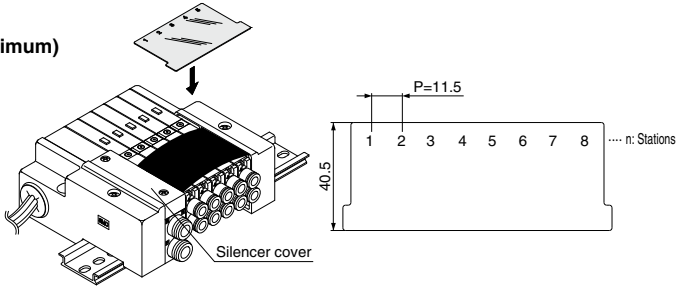

Blanking plug (For One-touch fitting)

23
KQ2P-04
06
08

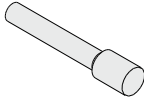

It is inserted into an unused cylinder port and SUP/EXH ports.

Purchasing order is available in units of 10 pieces.

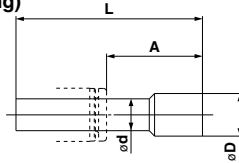

Dimensions

Applicable fittings size ød	Model	A	L	D
3.2	KQ2P-23	16	31.5	5
4	KQ2P-04	16	32	6
6	KQ2P-06	18	35	8
8	KQ2P-08	20.5	39	10

Port plug

VVQZ100-CP

The plug is used to block the cylinder port when using a 5-port valve as a 3-port valve.

* Add "A" or "B" at the end of the valve part number when ordering with valves.

Example) SQ1131-51-C6-A (N.O. specifications)

↓ 4 (A) port plug

Example) SQ1131-51-C6-B (N.C. specifications)

↓ 2 (B) port plug

Example) SQ1131-51-C6-B-M

(B port plug with manifold block)

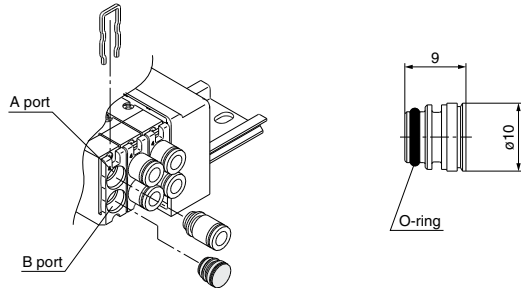

Direct EXH outlet, built-in silencer [-S]

This is a type with an exhaust port atop the manifold end plate. The built-in silencer exhibits an excellent noise suppression effect. (Noise reduction: 30 dB)

Note) A large quantity of drainage generated in the air source results in exhaust of air together with drainage.

* When ordering this option incorporated with a manifold, suffix "-S" to the end of the manifold part number.

* For precautions on handling and how to replace elements, refer to page 711.

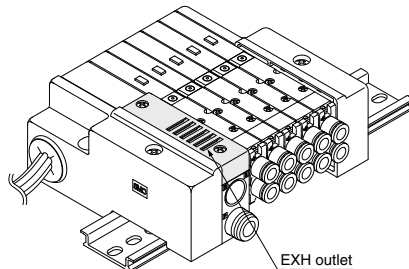

Manifold Option Parts for SQ1000

External pilot specifications [-R]

This can be used when the air pressure is 0.1 to 0.2 MPa lower than the minimum operating pressure of the solenoid valves or used for vacuum specifications.
Add "R" to the part numbers of manifolds and valves to indicate the external pilot specification.
An M5 port will be installed on the top side of the manifold's SUP/EXH block.

- How to order valves (Example)
SQ1130 **R** -51-C6
 ↓
 External pilot specifications
- How to order manifold (Example)
* Indicate "R" for an option.
SS5Q13-08FD1-D**R**
 ↓
 External pilot specifications

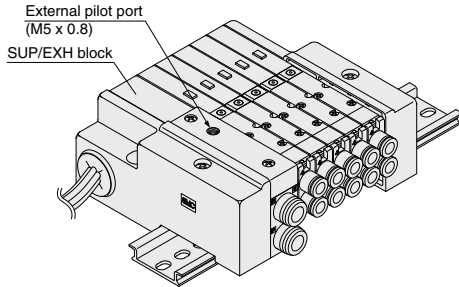

Note 1) Not applicable for 4 position dual 3 port valves.
Note 2) Valves with the external pilot specifications have a pilot EXH with individual exhaust specifications and EXH can be pressurized. However, the pressure supplied from EXH should be 0.4 MPa or lower.

Dual flow fitting

SSQ1000-52A-[C8]

↓ Port size

C8	ø8
N9	ø5/16"

To drive a large bore cylinder, two valve stations are operated simultaneously to double the air flow.
This fitting is used on the cylinder ports in this situation. Available sizes are ø8 and ø5/16" One-touch fittings.

* When ordering with valves, specify the valve part number without One-touch fitting and list without One-touch fitting and list the dual flow fitting part number.

Example) Valve part number (without Onetouch fitting)
SQ1131-51-[C8]..... 2 sets
*SSQ1000-52A-**C8**..... 1 set

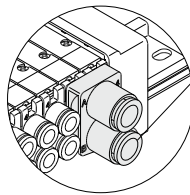

C8: One-touch fittings for ø8
N9: One-touch fittings for ø5/16"

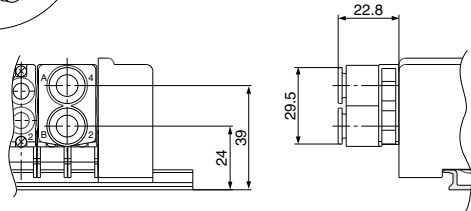

Silencer (For EXH port)

This is inserted into the centralized type EXH port (One-touch fitting).

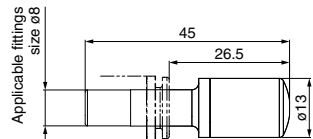
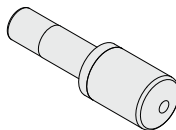

Specifications

Series	Model	Effective area mm ² (Cv factor)	Noise reduction (dB)
SQ1000	AN15-C08	20 (1.1)	30

SQ2000 Series

Manifold Option Parts for SQ2000

Blanking plate

SSQ2000-10A-3

It is used by attaching on the manifold block for being prepared for removing a valve for maintenance reasons or planning to mount a spare valve, etc.

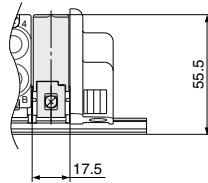
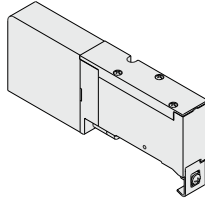

Symbol



SUP/EXH block

SSQ2000-PR-3-C10-□

Port size

C8	One-touch fittings for ø8
C10	One-touch fittings for ø10
N9	One-touch fittings for ø5/16"
N11	One-touch fittings for ø3/8"

Option

Nil	Standard
R	External pilot specifications
S	Built-in silencer

Note) When specifying both options, indicate "RS".

* Specify the spacer mounting position on the manifold specification sheet.

For standard type manifolds, the SUP/EXH block is mounted on the D side.

It is added to the manifold to increase SUP/EXH capacity.

* The number of SUP/EXH blocks that can be added is limited to two sets, one between manifold stations and another on the U side of the manifold due to the length of the internal lead wire.

* SUP/EXH blocks are not included in the number of manifold stations.

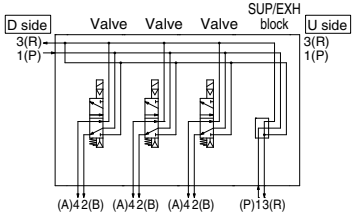
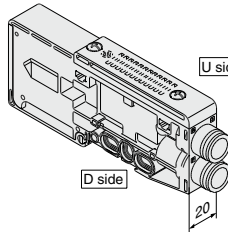

Individual SUP spacer

SSQ2000-P-3-C8

Port size

Side ported	C8	One-touch fittings for ø8
Top ported	N9	One-touch fittings for ø5/16"
Top ported	L8	One-touch fittings for ø8
Top ported	LN9	One-touch fittings for ø5/16"

This is used as a supply port for different pressures when using different pressures in the same manifold (for one station).

Both sides of the station which is used with supply pressure from the individual SUP spacer are shut off. (Refer to application example.)

* Specify the spacer mounting position and SUP passage shut off positions on the manifold specification sheet. Up to two shut off positions can be specified per unit. (Two pieces of SUP block plate that shut off the supply pressure are included with the individual SUP spacer, therefore, it is not necessary to order them separately.)

* Electrical wiring is also connected to the manifold station with the individual SUP spacer.

* By changing the fitting shown in the drawing and the block plates, the spacer's specification can be changed later (from the individual SUP spacer to the individual EXH spacer).

* The number of spacers is not limited when ordered with the manifold. However, when adding individual SUP spacers later, it is limited to two units, and another on the U side due to the length of the internal lead wire.

* Model no. with manifold block:

SSQ2000-P-3-C8-M

644

Side ported

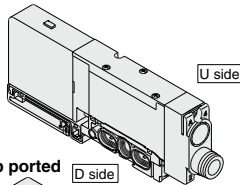

Top ported

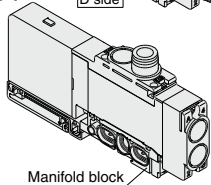

For top ported

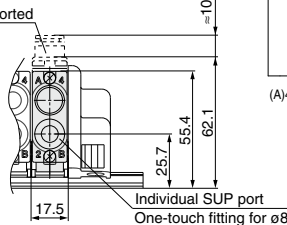

		Stations				
Description/Model		1	2	3	4	5
Valve	Single	●	●	●		
	...					
Option	Individual SUP spacer SSQ2000-P-3-C8		●			
	SUP shut off position: Please specify.	●		●		

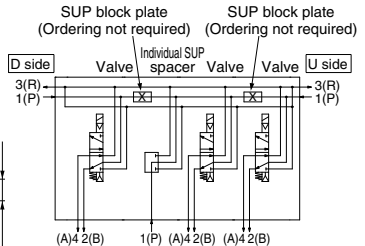

Manifold Option Parts for SQ2000

Individual EXH spacer

SSQ2000-R-3-**C8**

● **Port size**

Side ported	C8	One-touch fittings for ø8
ported	N9	One-touch fittings for ø5/16"
Top ported	L8	One-touch fittings for ø8
ported	LN9	One-touch fittings for ø5/16"

This is used to exhaust an individual valve when the exhaust from a valve interferes with other stations in the circuit (used for one station).

Both sides of the station which is to be individually exhausted are shut off. (Refer to application example.)

* Specify the spacer mounting position and EXH passage shut off positions on the manifold specification sheet. Up to two shut off positions can be specified per unit. (Four pieces of EXH block plate that shut off the exhaust are included with the individual EXH spacer, therefore, it is not necessary to order them separately.)

* Electrical wiring is also connected to the manifold station with the individual EXH spacer.

* By changing the fitting shown in the drawing and the block plates, the spacer's specification can be changed later (from the individual EXH spacer to the individual SUP spacer).

* The number of spacers is not limited when ordered with the manifold. However, when adding individual EXH spacers later, it is limited to two units, one between manifold stations and another on the U side due to the length of the internal lead wire.

* Model no. with manifold block:
SSQ2000-R-3-**C8**-**M**

Side ported

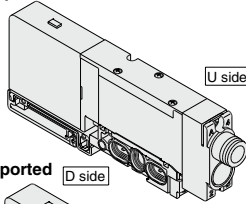

Top ported

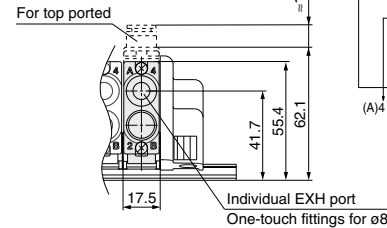
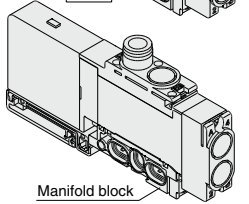

Description/Model	Stations				
	1	2	3	4	5
Valve	Single				
Option	Individual EXH spacer SSQ2000-R-3- C8				
Option	EXH shut off position: Please specify.				

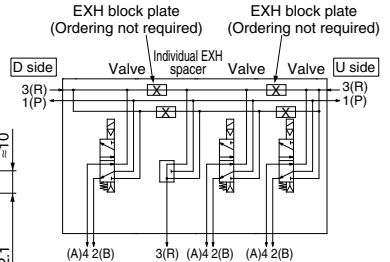

Individual SUP/EXH spacer

SSQ2000-PR1-3-**C8**

● **Port size**

Side ported	C8	One-touch fittings for ø8
ported	N9	One-touch fittings for ø5/16"
Top ported	L8	One-touch fittings for ø8
ported	LN9	One-touch fittings for ø5/16"

This has both functions of the individual SUP and EXH spacers above. (Refer to application example.)

* Specify the spacer mounting position and SUP and EXH passage shut off positions on the manifold specification sheet. Up to two shut off positions each for SUP and EXH can be specified per unit. [Block plates that shut off the SUP and EXH passages are included with the individual SUP/EXH spacer, therefore, it is not necessary to order them separately (2 pcs. of SUP block plate and 4 pcs. of EXH block plate).]

* Electrical wiring is also connected to the manifold station with the individual SUP/EXH spacer.

* By changing the fitting shown in the drawing and the block plates, the spacer's specification can be changed later.

* The number of spacers is not limited when ordered with the manifold. However, when adding individual SUP/EXH spacers later, it is limited to two units, one between manifold stations on the U side due to the length of the internal lead wire.

* Model no. with manifold block:
SSQ2000-PR1-3-**C8**-**M**

* Do not install any back pressure check valve on the manifold station, on which the spacer is to be mounted. When installing the back pressure check valve on other manifold station, be sure to specify the manifold station position on the manifold specification sheet instead of ordering by specifying the manifold option symbol "B".

Side ported

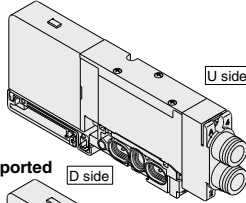

Top ported

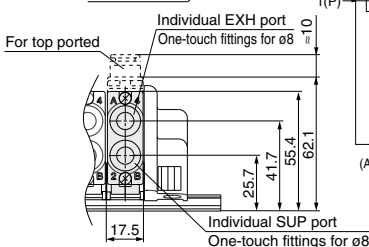
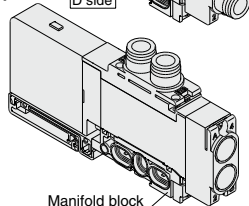

Description/Model	Stations				
	1	2	3	4	5
Valve	Single				
Option	Individual SUP/EXH spacer SSQ2000-PR1-3- C8				
Option	SUP shut off position: Please specify.				
Option	EXH shut off position: Please specify.				

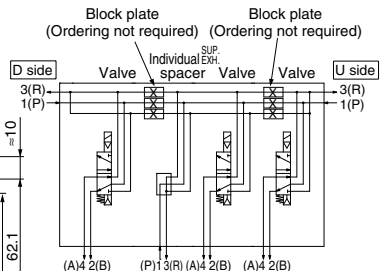

SQ2000 Series

Manifold Option Parts for SQ2000

SUP block plate

SSQ1000-B-R

When supplying two different pressures, high and low, to one manifold, this is used between stations with different pressures. Also, it is used with an individual SUP spacer to shut off the air supply.

- * Specify the station position on the manifold specification sheet.

<Block indication label>

When using block plates for SUP passage, indication label for confirmation of the blocking position from outside is attached. (One label of each)

- * When ordering a block plate for SUP incorporated with the manifold, a block indication label is attached to the manifold.

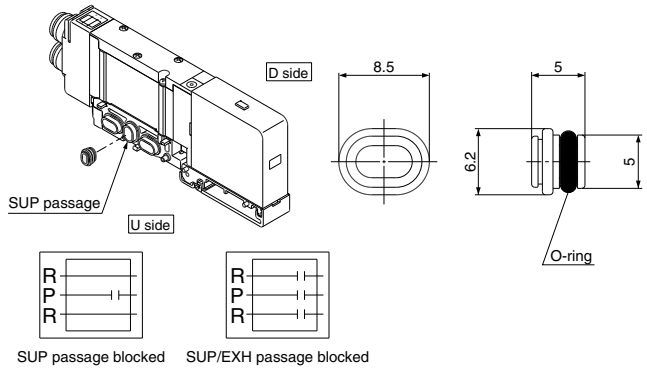

EXH block plate

SSQ2000-B-R

When the exhaust from a valve interferes with other stations in the circuit, this is used between stations to separate exhausts. Also, it is used with an individual EXH spacer to shut off the exhaust of individual valves.

- * Specify the station position on the manifold specification sheet.
- * Be sure to discharge the exhaust inside the EXH passage from the R port of the SUP/EXH block, etc. so that the exhaust pressure is not sealed.

<Block indication label>

When using block plates for EXH passage, indication label for confirmation of the blocking position from outside is attached. (One label of each)

- * When ordering a block plate for EXH incorporated with the manifold, a block indication label is attached to the manifold.

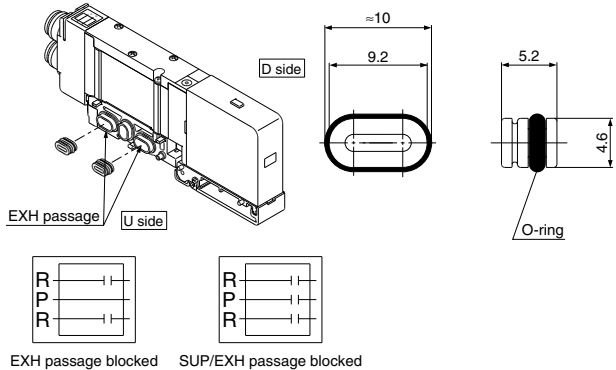

Back pressure check valve [-B]

SSQ2000-BP

It prevents cylinder malfunction caused by other valve exhaust. Insert it into R (EXH) port on the manifold side of a valve which is affected. It is effective when a single action cylinder is used or an exhaust center type solenoid valve is used.

- * When a check valve for back pressure prevention is desired, and is to be installed only in certain manifold stations, clearly write the part number and specify the number of stations on the manifold specification sheet.
- * When ordering this option incorporated with a manifold, suffix "-B" to the end of the manifold part number.

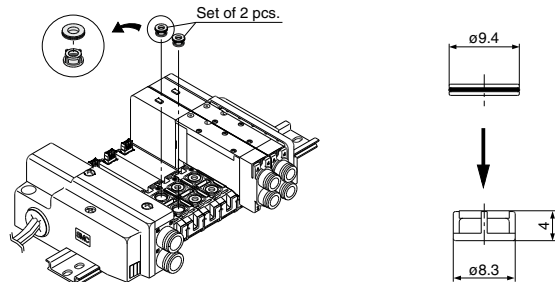

⚠ Caution

1. The manifold installed type back pressure check valve assembly is assembly parts with a check valve structure. However, since slight air leakage against the back pressure is allowed due to its structure, adverse effects of the back pressure due to increase in exhaust resistance cannot be prevented if the manifold exhaust port and other exhaust ports are put together for piping or if the piping diameter is narrowed. As a result, this may cause the actuator and air operated equipment to malfunction. So, be careful not to restrict the exhaust air. If the exhaust resistance becomes large, select a built-in valve type with rubber seal.
2. When a back pressure check valve is mounted, the effective area of the valve will decrease by about 20%.

Manifold Option Parts for SQ2000

Name plate [-N]

SSQ2000-N3- Stations (1 to maximum)

It is a transparent resin plate for placing a label that indicates solenoid valve function, etc.

Insert it into the groove on the side of the end plate and bend it as shown in the figure. Also, the plate is difficult to bend for manifolds with only a few stations, therefore, remove the silencer cover to install it.

* When ordering this option incorporated with a manifold, suffix "-N" to the end of the manifold part number.

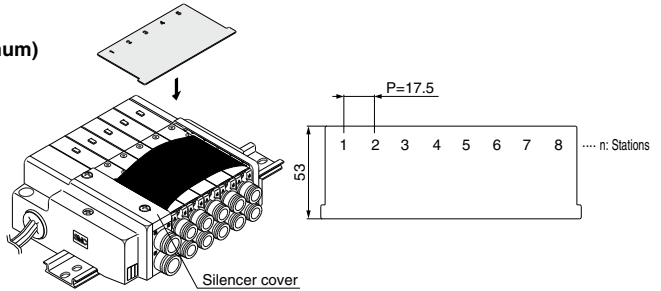

Blanking plug (For One-touch fitting)

04
KQ2P-
06
08
10

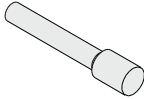

It is inserted into an unused cylinder port and SUP/EXH ports.

Purchasing order is available in units of 10 pieces.

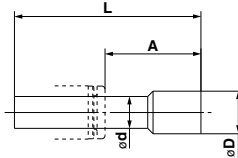

Dimensions

Applicable fittings size ϕd	Model	A	L	D
4	KQ2P-04	16	32	6
6	KQ2P-06	18	35	8
8	KQ2P-08	20.5	39	10
10	KQ2P-10	22	43	12

Port plug

VVQZ2000-CP

The plug is used to block the cylinder port when using a 5-port valve as a 3-port valve.

* Add "A" or "B" at the end of the valve part number when ordering with valves.

Example) SQ2131-51-C8-A (N.O. specifications)

↓ 4 (A) port plug

Example) SQ2131-51-C8-B (N.C. specifications)

↓ 2 (B) port plug

Example) SQ2131-51-C8-B-M

(B port plug with manifold block)

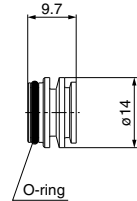
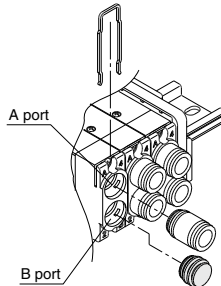

Direct EXH outlet, built-in silencer [-S]

This is a type with an exhaust port atop the manifold end plate. The built-in silencer exhibits an excellent noise suppression effect. (Noise reduction: 30 dB)

Note) A large quantity of drainage generated in the air source results in exhaust of air together with drainage.

* When ordering this option incorporated with a manifold, suffix "-S" to the end of the manifold part number.

* For precautions on handling and how to replace elements, refer to page 711.

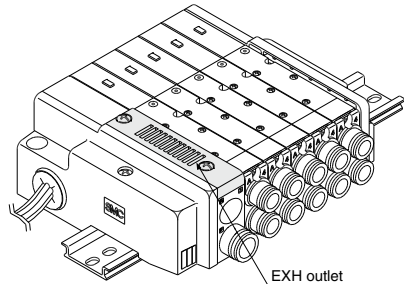

SQ2000 Series

Manifold Option Parts for SQ2000

External pilot specifications [-R]

This can be used when the air pressure is 0.1 to 0.2 MPa lower than the minimum operating pressure of the solenoid valves or used for vacuum specifications.

Add "R" to the part numbers of manifolds and valves to indicate the external pilot specifications.

An M5 port will be installed on the top side of the manifold's SUP/EXH block.

- How to order valves (Example)
SQ2130 **R** -51-C6
↓ External pilot specifications

- How to order manifold (Example)
* Indicate "R" for an option.
SSSQ23-08FD1-**DR**
↓ External pilot specifications

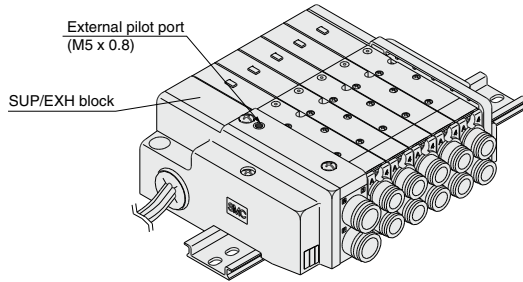

Note 1) Not applicable for dual 3 port valves.

Note 2) Valves with the external pilot specifications have a pilot EXH with individual exhaust specifications and EXH can be pressurized. However, the pressure supplied from EXH should be 0.4 MPa or lower.

Dual flow fitting

SSSQ2000-52A-**C10**

● Port size	
C10	ø10
N11	ø3/8"

To drive a large bore cylinder, two valve stations are operated simultaneously to double the air flow. This fitting is used on the cylinder ports in this situation. Available sizes are ø10 and ø3/8" One-touch fittings.

* When ordering with valves, specify the valve part number without One-touch fitting and list without One-touch fitting and list the dual flow fitting part number.

Example) Valve part number (without One-touch fitting)

SQ2131-51-**C10**..... 2 sets
* SSSQ2000-52A-**C10**..... 1 set

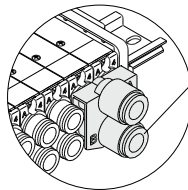

C10: One-touch fitting for ø10
N11: One-touch fitting for ø3/8"

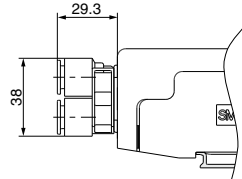
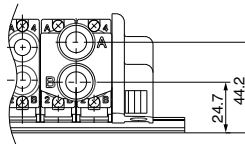

Silencer (For EXH port)

This is inserted into the centralized type EXH port (One-touch fitting).

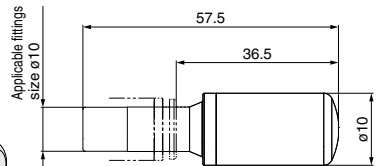
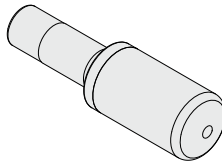

Specifications

Series	Model	Effective area (mm ²) (Cv factor)	Noise reduction (dB)
SQ2000	AN20-C10	30 (1.6)	30

Manifold Option for SQ1000/2000

Special Wiring Specifications

In the internal wiring of F kit, P kit, T kit and S kit, double wiring (connected to SOL. A and SOL. B) is adopted for each station regardless of the valve and option types. Mixed single and double wiring is available as an option.

1. How to Order

Indicate option symbol "K" in the manifold part number and be sure to specify station positions for single or double wiring on the manifold specification sheet. Also, specify wiring for spare connectors.

(Up to two spare connectors are included depending on the remaining number of connector pins. When the wiring for the spare connectors is not specified, they will be wired according to "Spare Connector Wiring" on page 652.)

Example) **SS5Q13 -09|FD0|DKS**

↓ Others, option symbols: to be indicated alphabetically.

2. Wiring specifications

Connector terminal numbers are connected from solenoid station 1 on the A side in the order indicated by the arrows without skipping any terminal numbers.

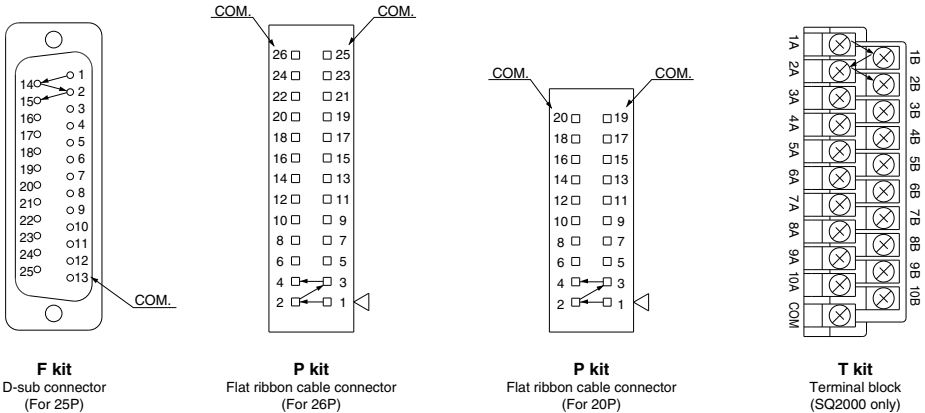

For S kit (serial transmission kit), refer to page 657.

3. Maximum stations

The maximum number of manifold stations is determined by the number of solenoids. Count one point for a single solenoid type and two points for a double solenoid type. Determine the number of stations so that the total number of solenoids is no more than the maximum points in the table below.

Kit	F kit (D-sub connector)	P kit (Flat ribbon cable connector)		T kit (Terminal block) SQ2000 only*	S kit (Serial)
Type	FD□ 25P	PD□ 26P	PDC 20P	TD0	SD□
Max. points	24 points	24 points	18 points	20 points	16 points

Note) Maximum stations ... SQ1000: 24 stations
SQ2000: 16 stations

SQ1000/2000 Series

Manifold Option for SQ1000/2000

Special DIN Rail Length (DIN Rail Mounting (-D) Only)

The standard DIN rail provided is approximately 30 mm longer than the overall length of the manifold with a specified number of stations. The following options are also available.

● DIN rail length longer than the standard type (for stations to be added later, etc.)

In the manifold part number, specify "D" for the manifold mounting symbol and add the number of required stations after the symbol.

Example) **SS5Q13-08FD0-D09BNK**



● Ordering DIN rail only

DIN rail part number

AXT100-DR-n

Note) For "n", enter a number from the "No." line in the table below.
For L dimension, refer to the dimensions of each kit.

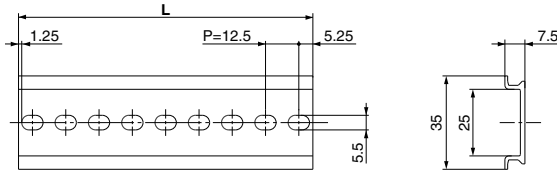

L Dimension

$$L = 12.5 \times n + 10.5$$

No.	1	2	3	4	5	6	7	8	9	10
L dimension	23	35.5	48	60.5	73	85.5	98	110.5	123	135.5

No.	11	12	13	14	15	16	17	18	19	20
L dimension	148	160.5	173	185.5	198	210.5	223	235.5	248	260.5

No.	21	22	23	24	25	26	27	28	29	30
L dimension	273	285.5	298	310.5	323	335.5	348	360.5	373	385.5

No.	31	32	33	34	35	36	37	38	39	40
L dimension	398	410.5	423	435.5	448	460.5	473	485.5	498	510.5

Direct Mounting Type (-E)

Manifold is mounted by using mounting holes of both sides of the manifold.
DIN rail is not sticking out of the edge of end plate. (Except SQ2000 T kit type. Refer to pages 634 and 635.)
Furthermore, the reinforcing part that comes to the bottom of the DIN rail is attached to the end plate assembly.

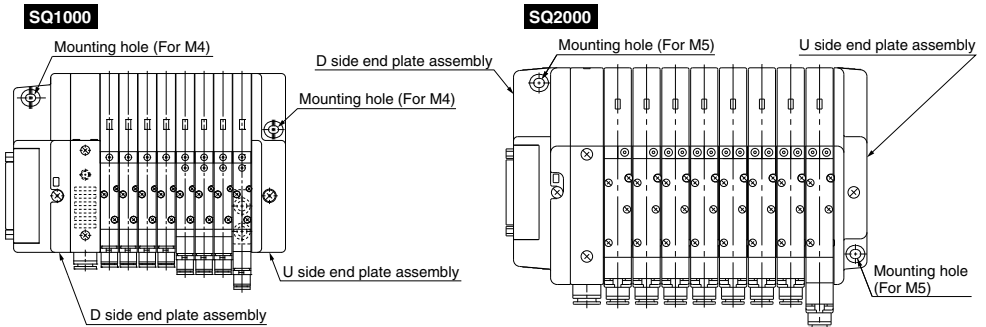

Manifold Option for SQ1000/2000

Negative Common Specifications

The following valve part numbers are for negative common specifications. Manifold part numbers are the same as the standard except L kit. Also, negative common specifications are not available for the S kit.

● How to order negative common valves (Example)

SQ1130 **N** -51-C6

↓ Negative common specifications

● How to order negative common manifold (Example)

SS5Q13 -**08****LD1** **N** -**DIN**

↓ Stations

↓ Kit type

↓ Option

↓ DIN rail mounting type

↓ Negative common specifications

Inch-size One-touch Fittings

For One-touch fittings in inch sizes, use the following part numbers. Also, the color of the release button is orange.

● How to order valves (Example)

SQ1130- 51 - **N7**

Port location ↓

Cylinder port ↓

Nil	Side ported
L	Top ported

Symbol	N1	N3	N7	N9
Applicable tubing O.D. (Inch)	ø1/8"	ø5/32"	ø1/4"	ø5/16"
4(A),	●	●	●	—
2(B) port	—	●	●	●

● How to order manifold (Example)

Add "00T" at the end of the part number.

SS5Q13-**08****FD0**-**DN**- **00T**

↓ 1 (P), 3 (R) port in inch size
 { SQ1000: ø5/16" (N9)
 { SQ2000: ø3/8" (N11)

SQ1000/2000 Series

How to Increase Manifold Stations for SQ1000/2000

1. Using Spare Connector to Add Stations

As shown in the table below, wiring specifications for spare connectors are based on to the remaining number of connector pins (remaining number of pins against the maximum number of solenoids for each kit.)

The following steps are for using spare connectors to add stations.

• Spare Connector Wiring

Remaining connector pins	4 pins or more	3 pins	2 pins	1 pin	0 pin
Spare connector wiring	2 for double wiring	1 for double wiring (on the low no. station side) 1 for single wiring	1 for double wiring	1 for single wiring	None

What to order

- Valves with manifold block (refer to pages 607 and 625) or the manifold blocks (Refer to page 653).

Steps for adding stations

- ① Loosen the clamp screw on the U side end plate and open the manifold.
- ② Mount the manifold block to be added.
- ③ Open the junction cover and attach the spare connector. Match the station position of the added station and the spare connector station number.
- ④ Press on the end plate to eliminate any space between the manifold blocks and tighten the clamp screw.
(Proper tightening torque: 0.8 to 1.0 N·m)
Note 1) Order a manifold block with lead wire for the L kit because a spare connector is not included with the kit. (Refer to page 653.)
Note 2) Do not let the lead wires get caught between manifolds, or when closing the junction cover.

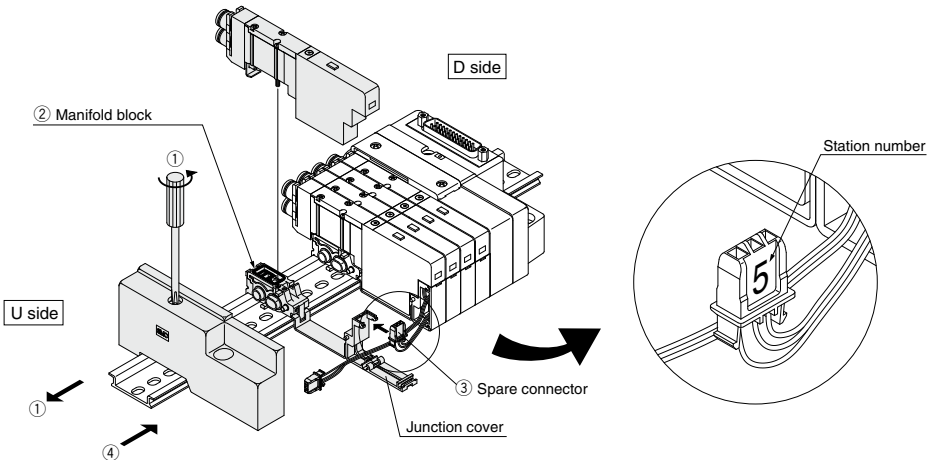

How to Increase Manifold Stations for SQ1000/2000

2. Adding Stations Without Required Spare Connectors

Spare connectors for 2 stations are initially included. However, to add 3 or more stations, order manifold blocks with lead wire in the tables below.

How to order manifold blocks with lead wire

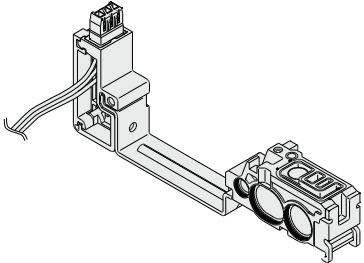
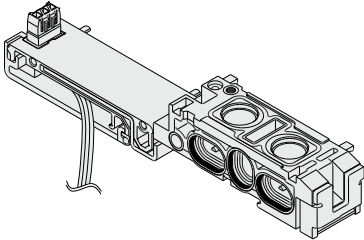
SQ1000	SQ2000																																												
																																													
<p>SSQ1000-1A-3-FS03 </p>	<p>SSQ2000-1A-3-FS03 </p>																																												
<p>Lead wire type ●</p>	<p>Lead wire type ●</p>																																												
<table border="1" style="width: 100%; border-collapse: collapse;"> <tr><td style="text-align: center;">F0</td><td>Without lead wire (for using spare connectors to add stations)</td></tr> <tr><td style="text-align: center;">FS</td><td>F kit (D-sub connector kit) Single wiring</td></tr> <tr><td style="text-align: center;">FW</td><td>F kit (D-sub connector kit) Double wiring</td></tr> <tr><td style="text-align: center;">PS</td><td>P kit (Flat ribbon cable kit) Single wiring</td></tr> <tr><td style="text-align: center;">PW</td><td>P kit (Flat ribbon cable kit) Double wiring</td></tr> <tr><td style="text-align: center;">L0</td><td>L kit (Lead wire kit) Lead wire length 0.6 m</td></tr> <tr><td style="text-align: center;">L1</td><td>L kit (Lead wire kit) Lead wire length 1.5 m</td></tr> <tr><td style="text-align: center;">L2</td><td>L kit (Lead wire kit) Lead wire length 3.0 m</td></tr> <tr><td style="text-align: center;">SS</td><td>S kit (Serial transmission kit) Single wiring</td></tr> <tr><td style="text-align: center;">SW</td><td>S kit (Serial transmission kit) Double wiring</td></tr> </table>	F0	Without lead wire (for using spare connectors to add stations)	FS	F kit (D-sub connector kit) Single wiring	FW	F kit (D-sub connector kit) Double wiring	PS	P kit (Flat ribbon cable kit) Single wiring	PW	P kit (Flat ribbon cable kit) Double wiring	L0	L kit (Lead wire kit) Lead wire length 0.6 m	L1	L kit (Lead wire kit) Lead wire length 1.5 m	L2	L kit (Lead wire kit) Lead wire length 3.0 m	SS	S kit (Serial transmission kit) Single wiring	SW	S kit (Serial transmission kit) Double wiring	<table border="1" style="width: 100%; border-collapse: collapse;"> <tr><td style="text-align: center;">F0</td><td>Without lead wire (for using spare connectors to add stations)</td></tr> <tr><td style="text-align: center;">FS</td><td>F kit (D-sub connector kit) Single wiring</td></tr> <tr><td style="text-align: center;">FW</td><td>F kit (D-sub connector kit) Double wiring</td></tr> <tr><td style="text-align: center;">PS</td><td>P kit (Flat ribbon cable kit) Single wiring</td></tr> <tr><td style="text-align: center;">PW</td><td>P kit (Flat ribbon cable kit) Double wiring</td></tr> <tr><td style="text-align: center;">TS</td><td>T kit (Terminal block kit) Single wiring</td></tr> <tr><td style="text-align: center;">TW</td><td>T kit (Terminal block kit) Double wiring</td></tr> <tr><td style="text-align: center;">L0</td><td>L kit (Lead wire kit) Lead wire length 0.6 m</td></tr> <tr><td style="text-align: center;">L1</td><td>L kit (Lead wire kit) Lead wire length 1.5 m</td></tr> <tr><td style="text-align: center;">L2</td><td>L kit (Lead wire kit) Lead wire length 3.0 m</td></tr> <tr><td style="text-align: center;">SS</td><td>S kit (Serial transmission kit) Single wiring</td></tr> <tr><td style="text-align: center;">SW</td><td>S kit (Serial transmission kit) Double wiring</td></tr> </table>	F0	Without lead wire (for using spare connectors to add stations)	FS	F kit (D-sub connector kit) Single wiring	FW	F kit (D-sub connector kit) Double wiring	PS	P kit (Flat ribbon cable kit) Single wiring	PW	P kit (Flat ribbon cable kit) Double wiring	TS	T kit (Terminal block kit) Single wiring	TW	T kit (Terminal block kit) Double wiring	L0	L kit (Lead wire kit) Lead wire length 0.6 m	L1	L kit (Lead wire kit) Lead wire length 1.5 m	L2	L kit (Lead wire kit) Lead wire length 3.0 m	SS	S kit (Serial transmission kit) Single wiring	SW	S kit (Serial transmission kit) Double wiring
F0	Without lead wire (for using spare connectors to add stations)																																												
FS	F kit (D-sub connector kit) Single wiring																																												
FW	F kit (D-sub connector kit) Double wiring																																												
PS	P kit (Flat ribbon cable kit) Single wiring																																												
PW	P kit (Flat ribbon cable kit) Double wiring																																												
L0	L kit (Lead wire kit) Lead wire length 0.6 m																																												
L1	L kit (Lead wire kit) Lead wire length 1.5 m																																												
L2	L kit (Lead wire kit) Lead wire length 3.0 m																																												
SS	S kit (Serial transmission kit) Single wiring																																												
SW	S kit (Serial transmission kit) Double wiring																																												
F0	Without lead wire (for using spare connectors to add stations)																																												
FS	F kit (D-sub connector kit) Single wiring																																												
FW	F kit (D-sub connector kit) Double wiring																																												
PS	P kit (Flat ribbon cable kit) Single wiring																																												
PW	P kit (Flat ribbon cable kit) Double wiring																																												
TS	T kit (Terminal block kit) Single wiring																																												
TW	T kit (Terminal block kit) Double wiring																																												
L0	L kit (Lead wire kit) Lead wire length 0.6 m																																												
L1	L kit (Lead wire kit) Lead wire length 1.5 m																																												
L2	L kit (Lead wire kit) Lead wire length 3.0 m																																												
SS	S kit (Serial transmission kit) Single wiring																																												
SW	S kit (Serial transmission kit) Double wiring																																												
<p>Applicable stations ●</p> <table border="1" style="width: 100%; border-collapse: collapse;"> <tr><td style="text-align: center;">01</td><td>1 station</td></tr> <tr><td style="text-align: center;">⋮</td><td>⋮</td></tr> <tr><td style="text-align: center;">24</td><td>24 stations</td></tr> </table> <p>Note 1) "F0": Nil Note 2) S kit is from 01 to 16</p>	01	1 station	⋮	⋮	24	24 stations	<p>Applicable stations ●</p> <table border="1" style="width: 100%; border-collapse: collapse;"> <tr><td style="text-align: center;">01</td><td>1 station</td></tr> <tr><td style="text-align: center;">⋮</td><td>⋮</td></tr> <tr><td style="text-align: center;">16</td><td>16 stations</td></tr> </table> <p>Note 1) "F0": Nil</p>	01	1 station	⋮	⋮	16	16 stations																																
01	1 station																																												
⋮	⋮																																												
24	24 stations																																												
01	1 station																																												
⋮	⋮																																												
16	16 stations																																												
<p>COM. (L kit only) ●</p> <table border="1" style="width: 100%; border-collapse: collapse;"> <tr><td style="text-align: center;">Nil</td><td>Positive common</td></tr> <tr><td style="text-align: center;">N</td><td>Negative common</td></tr> </table>	Nil	Positive common	N	Negative common	<p>COM. (L kit only) ●</p> <table border="1" style="width: 100%; border-collapse: collapse;"> <tr><td style="text-align: center;">Nil</td><td>Positive common</td></tr> <tr><td style="text-align: center;">N</td><td>Negative common</td></tr> </table>	Nil	Positive common	N	Negative common																																				
Nil	Positive common																																												
N	Negative common																																												
Nil	Positive common																																												
N	Negative common																																												
<p>Option ●</p> <table border="1" style="width: 100%; border-collapse: collapse;"> <tr><td style="text-align: center;">Nil</td><td>None</td></tr> <tr><td style="text-align: center;">B</td><td>Back pressure check valve</td></tr> <tr><td style="text-align: center;">R</td><td>External pilot specifications</td></tr> </table> <p>Note) Enter "BR" for both options.</p>	Nil	None	B	Back pressure check valve	R	External pilot specifications	<p>Option ●</p> <table border="1" style="width: 100%; border-collapse: collapse;"> <tr><td style="text-align: center;">Nil</td><td>None</td></tr> <tr><td style="text-align: center;">B</td><td>Back pressure check valve</td></tr> <tr><td style="text-align: center;">R</td><td>External pilot specifications</td></tr> </table> <p>Note) Enter "BR" for both options.</p>	Nil	None	B	Back pressure check valve	R	External pilot specifications																																
Nil	None																																												
B	Back pressure check valve																																												
R	External pilot specifications																																												
Nil	None																																												
B	Back pressure check valve																																												
R	External pilot specifications																																												

SQ1000/2000 Series

How to Increase Manifold Stations for SQ1000/2000

3. Connection Method (Refer to page 652 regarding the steps for adding stations to a manifold block.)

Connect the round terminal of the red lead wire to the common terminal inside the junction cover.

(1) Connecting common terminals

Connect lead wire assemblies included with manifold blocks as follows.

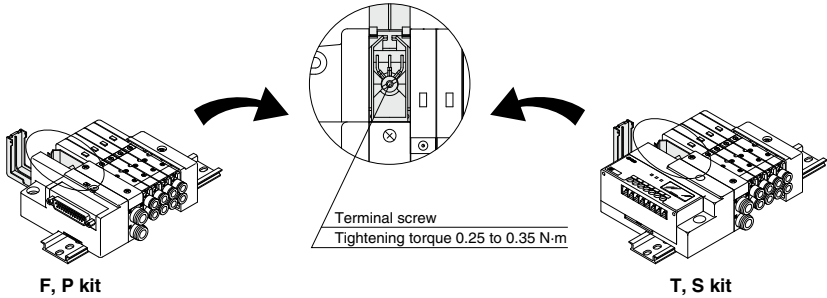

(2) Pulling out connector

Pull out the connector to connect the lead wire.

- For F and P kits, pull out and remove the housing while pressing down hard on the hook with a flat head screwdriver, etc. Remove the manual lever and lead wire cover, and pull out the connector.
- For T kits, remove the screws and pull out the terminal block.
- For S kits, remove the screws and pull out the connector.

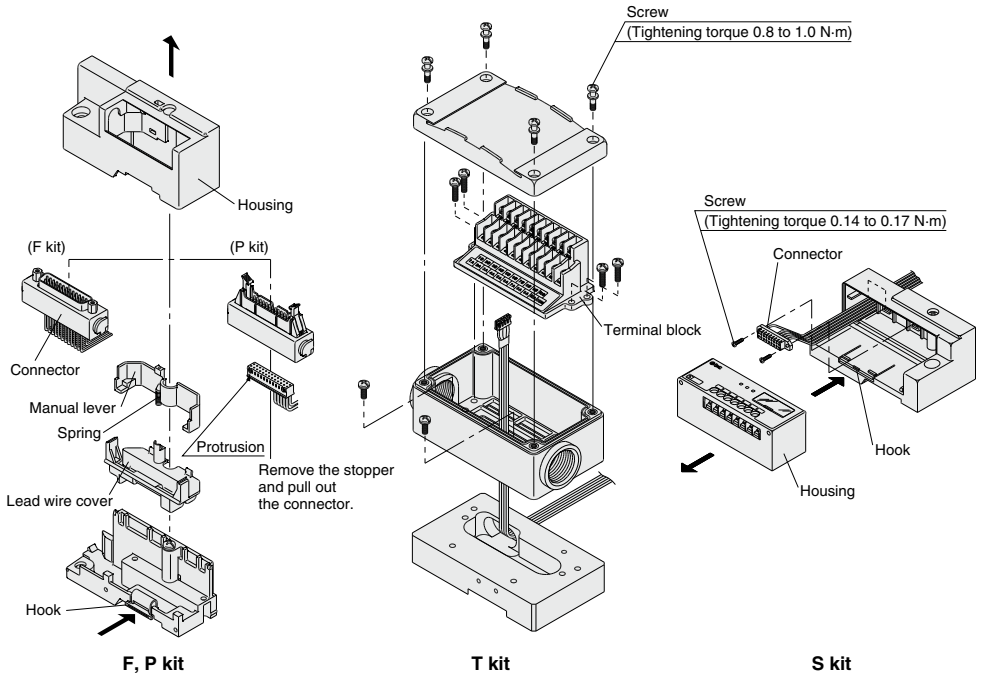

How to Increase Manifold Stations for SQ1000/2000

(3) Connect the black and white lead wire pins to the positions shown below in accordance with each kit.

- ⚠ Caution**
1. After inserting the pin, confirm that the pin hook is locked by lightly pulling the lead wire.
 2. Do not pull the lead wire forcefully when connecting. Also, take care that lead wires do not get caught between manifolds or when closing the junction cover.

Wiring (F Kit: D-sub Connector Kit)

Procedure) Based on the manifold specifications, station 1 of SOL.A (black wire) will be terminal number 1 of the D-sub connector, and for station 2 and thereafter, connect black wires, then white wires in the order as shown below by the arrows.

Manifold Specifications' Example

Stations	1	2	3	4	5	6
Single wiring	○	○				
Double wiring			○	○	○	

* The drawing above shows connections based on the manifold specifications' example in the table to the left.

Wiring (P Kit: Flat Ribbon Cable Kit)

Procedure) Based on the manifold specifications, station 1 of SOL.A (black wire) will be terminal number 1B of the flat ribbon cable connector, and for station 2 and thereafter, connect black wires, then white wires in the order as shown below by the arrows.

Manifold Specifications' Example

Stations	1	2	3	4	5	6
Single wiring	○	○				○
Double wiring			○	○	○	

* The drawing above shows connections for type 26P flat ribbon cable connector based on the manifold specifications' example in the table to the left. For type 20P, the connection will be the same as above except that COM changes to 10A and 10B.

SQ1000/2000 Series

How to Increase Manifold Stations for SQ1000/2000

Wiring (T Kit: Terminal Block Kit)

Procedure) Based on the manifold specifications, connect to the housing according to the wiring example below.

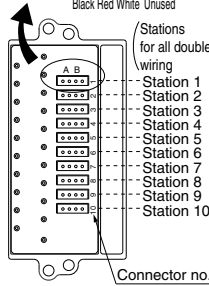
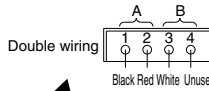
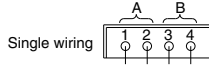
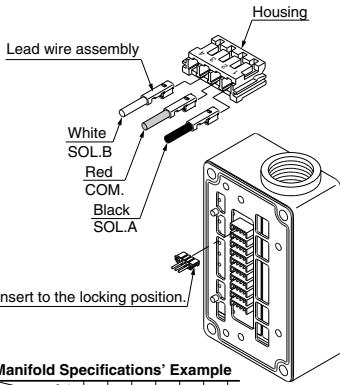

	Lead wire color	Terminal no.
1 station {	SOL.A _o	Black Station 1: 1
	COM. _o	Red Station 1: 2
2 stations {	SOL.A _o	Black Station 1: 3
	COM. _o	Red Station 1: 4
3 stations {	SOL.A _o	Black Station 2: 1
	COM. _o	Red Station 2: 2
4 stations {	SOL.A _o	Black Station 2: 3
	COM. _o	Red Station 2: 4
5 stations {	SOL.B _o	White Station 3: 1
	SOL.A _o	Black Station 3: 3
6 stations {	COM. _o	Red Station 3: 4
	SOL.B _o	White Station 4: 1
7 stations {	SOL.A _o	Black Station 4: 3
	COM. _o	Red Station 4: 4

Manifold Specifications' Example

Stations	1	2	3	4	5	6
Single wiring	○	○	○	○	○	○
Double wiring				○	○	

How to Increase Manifold Stations for SQ1000/2000

Wiring (S Kit: Serial Transmission Kit)

Procedure) Based on the manifold specifications, station 1 of SOL.A (black wire) will be terminal number 1 of the serial connector, and for station 2 and thereafter, connect black wires, then white wires in the order as shown below by the arrows.

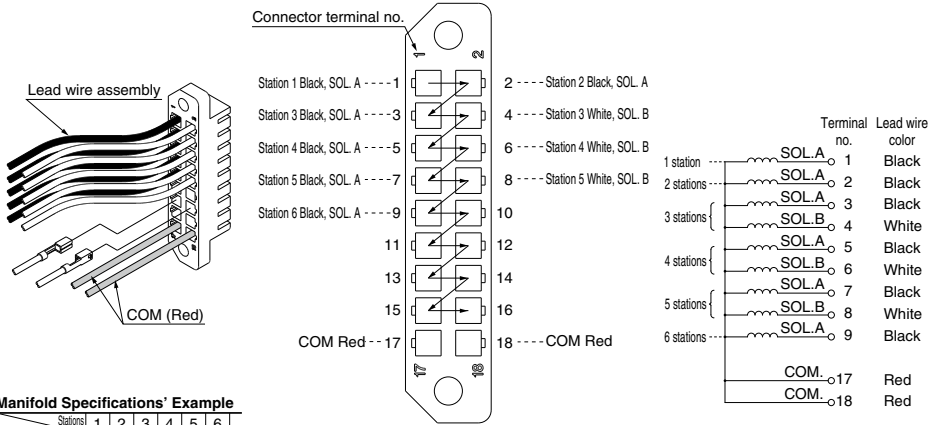

* The drawing above shows connections based on the manifold specifications' example in the table to the left.

SQ1000 Series

Construction: SQ1000 Series Plug-in Type Main Parts and Pilot Valve Assembly

Metal seal type

Single: SQ1130

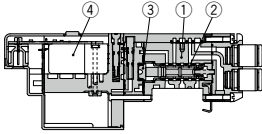

SQ1130



Rubber seal type

Single: SQ1131

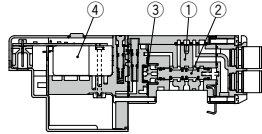

SQ1131



Double: SQ1230D

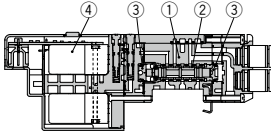

SQ1230D



Double: SQ1231D

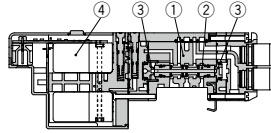

SQ1231D



3 position: SQ1430³₅

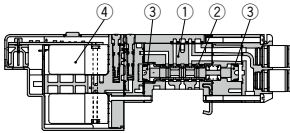

SQ1330



SQ1430



SQ1530



3 position: SQ1431³₅

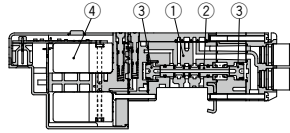

SQ1331



SQ1431



SQ1531



Component Parts

No.	Description	Material
1	Body	Zinc die-casted
2	Spool/Sleeve	Stainless steel (Metal seal)
	Spool	Aluminum (Rubber seal)
3	Piston	Resin
4	Pilot valve assembly	—

Dual 3 port valve: SQ1B31^A_C

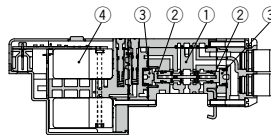

SQ1A31

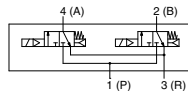

SQ1B31

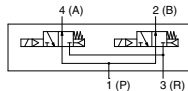

SQ1C31

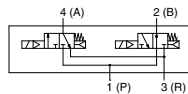

Construction: SQ2000 Series Plug-in Type Main Parts and Pilot Valve Assembly

Metal seal type

Single: SQ2130

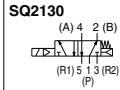
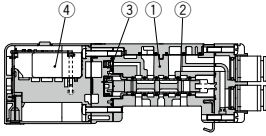

Rubber seal type

Single: SQ2131

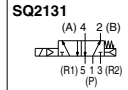
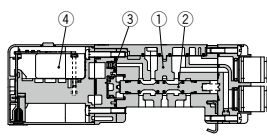

Double: SQ2230D

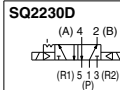
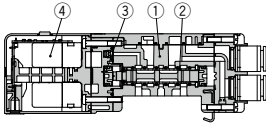

Double: SQ2231D

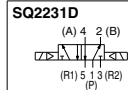
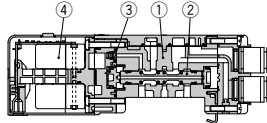

3 position: SQ2430

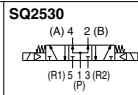
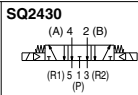
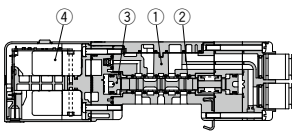

3 position: SQ2431

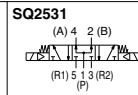
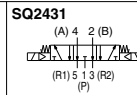
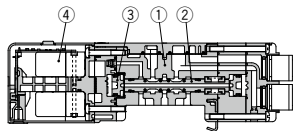

Component Parts

No.	Description	Material
1	Body	Aluminum die-casted
2	Spool/Sleeve	Stainless steel (Metal seal)
	Spool	Aluminum (Rubber seal)
3	Piston	Resin
4	Pilot valve assembly	—

Dual 3 port valve: SQ2B31

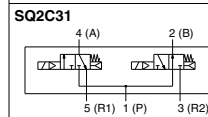
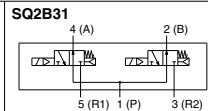
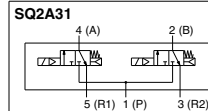
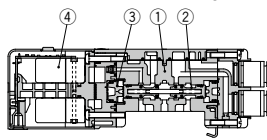

SQ1000 Series

Manifold Exploded View: SQ1000 (Plug-in Type Manifold) SS5Q13

(F, P, L, S kit)

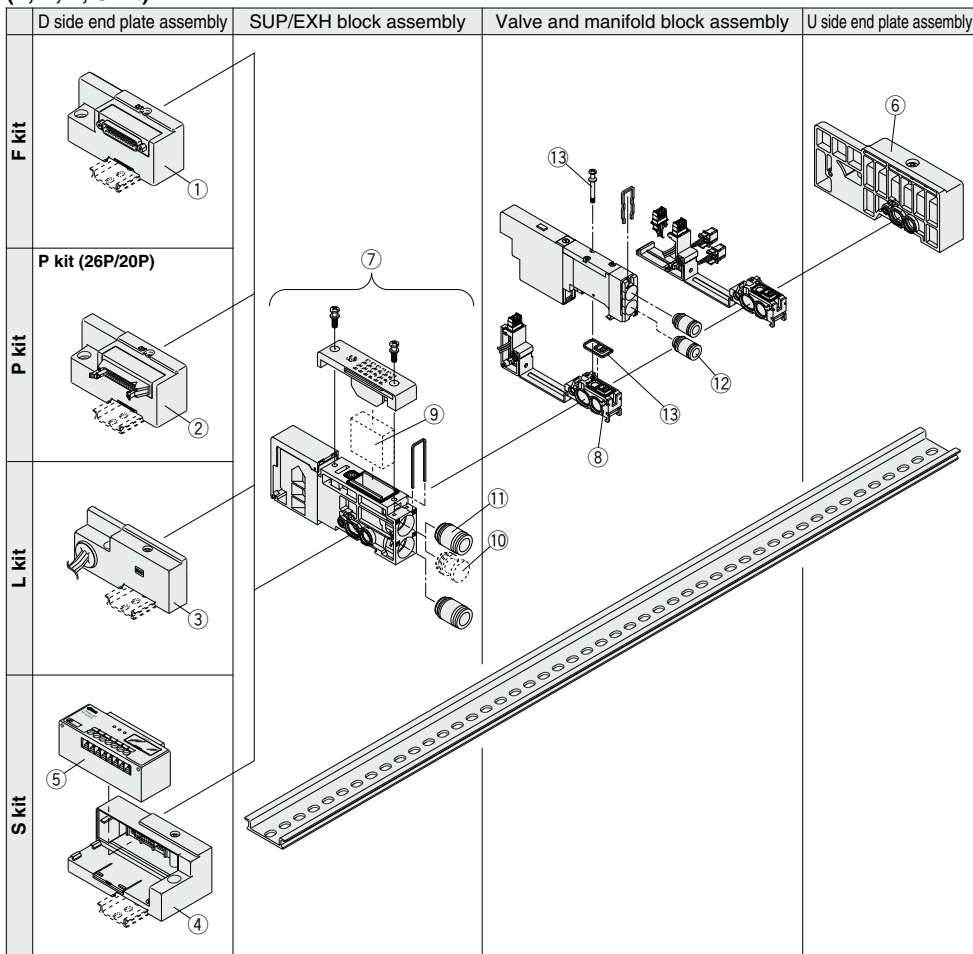

Manifold Spare Parts

Refer to pages 652 to 657 of "How to Increase Manifold Stations" regarding the mounting of each spare parts.

<① ② ③ ④ D side end plate assembly>

SSQ1000-3A-3 □ □ □ □

Manifold mounting ●

Nil	DIN rail mounting type
E	Direct mounting type

● Electrical entry

F	F kit	①
P	P kit (26P)	②
PC	P kit (20P)	③
Nil	L kit	④
S	S kit	④

● Wiring specifications

0	Without lead wire
S	Single wiring
W	Double wiring

Note) L kit: Nil

● Stations

01	For 1 station
⋮	⋮
24	For 24 stations

Note 1) The maximum number of stations will be different depending on the wiring specifications.

Note 2) L kit: Nil

<⑤ SI unit>

Manifold	No.	Description
SDQ kit	EX140-SDN1	DeviceNet® (16 output points)
SDR1 kit	EX140-SCS1	OMRON Corp.: CompoBus/S (16 output points)
SDR2 kit	EX140-SCS2	OMRON Corp.: CompoBus/S (8 output points)
SDV kit	EX140-SMJ1	CC-LINK (16 output points)

<⑨ Element>

SSQ1000-SE

Note) Part number for a 10 piece set of element.
For replacement procedures, refer to page 711.

<⑩ Port plug>

VVQZ2000-CP

<⑪ Fitting assembly>

(For P, R port)

VVQ1000-51A-C8

Port size ●

C6	One-touch fitting for ø6
C8	One-touch fitting for ø8
N7	One-touch fitting for ø1/4"
N9	One-touch fitting for ø5/16"

Note) Purchasing order is available in units of 10 pieces.

<⑥ U side end plate assembly>

(For F, P, S kit)

SSQ1000-2A-3 □ - 1

(For L kit)

SSQ1000-2A-3 □ - 2

● Manifold mounting

Nil	DIN rail mounting type
E	Direct mounting type

<⑦ SUP/EXH block assembly>

SSQ1000-PR-3-C8 □ □ □ □

Port size ●

C8	One-touch fitting for ø8
N9	One-touch fitting for ø5/16"

● Option

Nil	Common exhaust type
R	External pilot
S	Built-in silencer, direct exhaust

Note) Enter "RS" for both options.

<⑫ Fitting assembly>

(For cylinder port)

VVQ1000-50A-C3

Port size ●

C3	One-touch fitting for ø3.2
C4	One-touch fitting for ø4
C6	One-touch fitting for ø6
M5	M5 thread
N1	One-touch fitting for ø1/8"
N3	One-touch fitting for ø5/32"
N7	One-touch fitting for ø1/4"

Note) Purchasing order is available in units of 10 pieces.

<⑧ Manifold block assembly>

SSQ1000-1A-3-F0 01 □ □ □ □ Including gaskets ⑬

Lead wire type ●

F0	Without lead wire
FS	F kit: D-sub connector kit Single wiring
FW	F kit: D-sub connector kit Double wiring
PS	P kit: Flat ribbon cable kit Single wiring
PW	P kit: Flat ribbon cable kit Double wiring
L0	L kit: Lead wire kit Lead wire length 0.6 m
L1	L kit: Lead wire kit Lead wire length 1.5 m
L2	L kit: Lead wire kit Lead wire length 3 m
SS	S kit: Serial transmission kit Single wiring
SW	S kit: Serial transmission kit Double wiring

● Option

Nil	None
B	Back pressure check valve
R	External pilot specifications

Note) Enter "BR" for both options.

● COM. (L kit only)

Nil	Positive common
N	Negative common

● Applicable stations

01	Station 1
⋮	⋮
24	Station 24

Note 1) "F0": Nil

Note 2) Specify from "01" to "16" for S kit.

<⑬ Gasket and screw assembly>

SQ1000-GS

Note) Part number for 10 pieces each of gaskets and screws.

SQ2000 Series

Manifold Exploded View: SQ2000 (Plug-in Type Manifold) SS5Q23

(F, P, T, L, S kit)

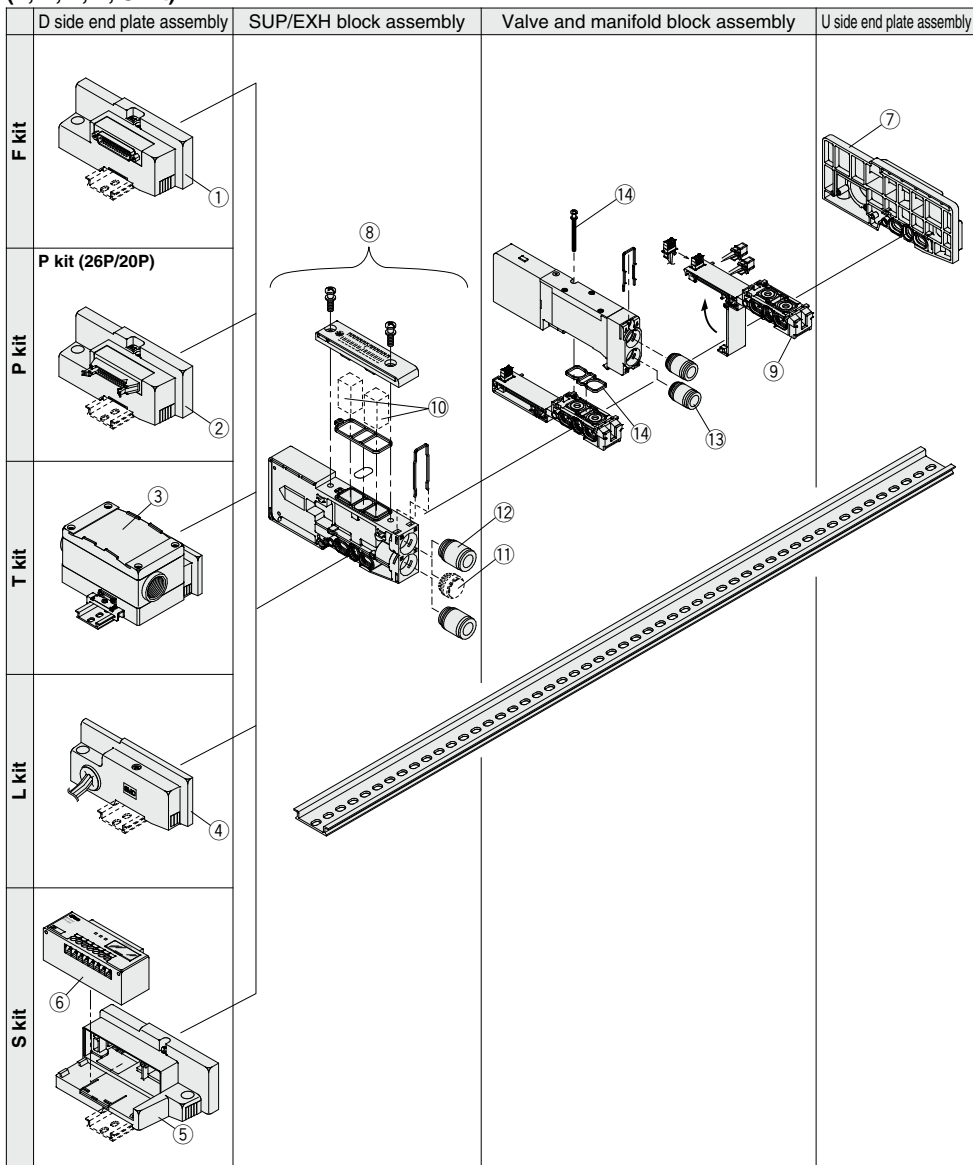

Manifold Spare Parts

Refer to pages 652 to 657 of "How to Increase Manifold Stations" regarding the mounting of each spare parts.

<① ② ③ ④ ⑤ D side end plate assembly>

SSQ2000 - 3A - 3

Manifold mounting

Nil	DIN rail mounting type
E	Direct mounting type

Electrical entry

F	F kit	①
P	P kit (26P)	②
PC	P kit (20P)	③
T	T kit	④
Nil	L kit	⑤
S	S kit	⑥

Wiring specifications

O	Without lead wire
S	Single wiring
W	Double wiring

Note) L kit: Nil

Stations

01	For 1 station
⋮	⋮
16	For 16 stations

Note 1) The maximum number of stations will be different depending on the wiring specifications.

Note 2) L kit: Nil

<⑥ SI unit>

Manifold	No.	Description
SDQ kit	EX140-SDN1	DeviceNet® (16 output points)
SDR1 kit	EX140-SCS1	OMRON Corp.: CompoBus/S (16 output points)
SDR2 kit	EX140-SCS2	OMRON Corp.: CompoBus/S (8 output points)
SDV kit	EX140-SMJ1	CC-LINK (16 output points)

<⑦ U side end plate assembly>

(For F, P, T, S kit)

SSQ2000 - 2A - 3

(For L kit)

SSQ2000 - 2A - 3

Manifold mounting

Nil	DIN rail mounting type
E	Direct mounting type

<⑧ SUP/EXH block assembly>

SSQ2000 - PR - 3 - C8

Port size

C8	One-touch fitting for ø8
C10	One-touch fitting for ø10
N9	One-touch fitting for ø5/16"
N11	One-touch fitting for ø3/8"

Option

Nil	Common exhaust type
R	External pilot
S	Built-in silencer, direct exhaust

Note) Enter "RS" for both options.

<⑨ Manifold block assembly>

SSQ2000 - 1A - 3 - F0

Lead wire type

F0	Without lead wire
FS	F kit: D-sub connector kit Single wiring
FW	F kit: D-sub connector kit Double wiring
PS	P kit: Flat ribbon cable kit Single wiring
PW	P kit: Flat ribbon cable kit Double wiring
TS	T kit: Terminal block kit Single wiring
TW	T kit: Terminal block kit Double wiring
L0	L kit: Lead wire kit Lead wire length 0.6 m
L1	L kit: Lead wire kit Lead wire length 1.5 m
L2	L kit: Lead wire kit Lead wire length 3 m
SS	S kit: Serial transmission kit Single wiring
SW	S kit: Serial transmission kit Double wiring

Option

Nil	None
B	Back pressure check valve
R	External pilot specifications

Note) Enter "BR" for both options.

COM. (L kit only)

Nil	Positive common
N	Negative common

Applicable stations

01	Station 1
⋮	⋮
16	Station 16

Note 1) *F0*: Nil

Including gaskets ⁽¹⁴⁾

<⑩ Element>

SSQ2000 - SE

Note) Part number for a 10 piece set of element.

For replacement procedures, refer to page 711.

<⑪ Port plug>

VVQZ3000 - CP

<⑫ Fitting assembly>

(For P, R port)

VVQ2000 - 51A - C8

Port size

C8	One-touch fitting for ø8
C10	One-touch fitting for ø10
N9	One-touch fitting for ø5/16"
N11	One-touch fitting for ø3/8"

Note) Purchasing order is available in units of 10 pieces.

<⑬ Fitting assembly>

(For cylinder port)

VVQ1000 - 51A - C4

Port size

C4	One-touch fitting for ø4
C6	One-touch fitting for ø6
C8	One-touch fitting for ø8
N3	One-touch fitting for ø5/32"
N7	One-touch fitting for ø1/4"
N9	One-touch fitting for ø5/16"

Note) Purchasing order is available in units of 10 pieces.

<⑭ Gasket and screw assembly>

SQ2000 - GS

Note) Part number for 10 pieces each of gaskets and screws.

Plug Lead Unit

SQ1000 Series



How to Order Manifold

SS5Q14 - **08** **FD2** - **D** - -

Stations

01	1 station
⋮	⋮
24 (Note)	24 stations

Note) The maximum number of stations depends on the type of electrical entries. Refer to "Electrical entry" for details.

CE/UKCA-compliant

Nil	—
Q	CE/UKCA-compliant

1(P), 3(R) port size

Nil	1(P), 3(R) port, One-touch fittings for ø8
00T	1(P), 3(R) port, One-touch fittings for ø5/16"

Manifold mounting

D DIN rail mounting type

Option

Nil	None
02 to 24 (1)	DIN rail length specified
B (2)(3)	Back pressure check valve
K (4)	Special wiring specifications (Except double wiring)
N	With name plate (Side ported only)
R	External pilot specifications
S	Built-in silencer, direct exhaust

Note 1) Specify DIN rail length with "D□" at the end. (Enter the number of stations inside □). The number of stations that may be displayed is longer than the manifold number of stations. Example: -D09

Note 2) When "-B" is selected, a back pressure check valve is included in all stations of the manifold. If the back pressure check valve is used only for the station that need it, then specify the station location in the manifold specification. ("-B" is not necessary)

Note 3) Since 4 port specification valves (5 (R1) and 3 (R2) are common) are used, back pressure cannot be prevented with dual 3 port valves.

Note 4) Specify "-K" for wiring specification for cases below. (Except C kit)

- All single wiring
- Single and double mixed wiring.

Specify the wiring specification in the manifold specification so that the number of solenoids is the maximum number of solenoids or less. (Standard wiring specification is double wiring)

Note 5) For specifying two or more options, enter them alphabetically. Example: -BKN
* Refer to pages 688 to 692 and 698 to 700 for manifold option parts.

Electrical entry

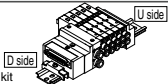
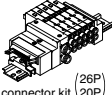
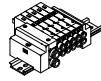
Kit type	Lead wire connector location	Cable specifications	Station	Max. number of solenoids for special wiring specifications (2)
F kit  D-sub Connector kit	D side	FD0	1 to 12 stations (Double wiring)	24
		FD1		
		FD2		
		FD3		
P kit  Flat ribbon cable connector kit (26P) (20P)	D side (1)	PD0	1 to 12 stations (Double wiring)	24
		PD1		
		PD2		
		PD3		
		PDC		
C kit  Connector kit	C	—	1 to 24 stations	—

Note 1) Separately order the 20P type cable assembly for the P kit.

Note 2) Specify the wiring so that the maximum number of solenoids is not exceeded. (The number of solenoids are counted as: 1 for single solenoids and 2 for type 3P and 4P double solenoids.)

* Refer to page 707 for manifold spare parts.

How to Order Valves

SQ1 1 4 0 - **5 L** - **1-C6** - - -

Seal

0	Metal seal
1	Rubber seal

Type of actuation

1	2 position single (A)4 2(B) (R1)5 1 3(R2) (P)
2	2 position double (Double solenoid) (1) (A)4 2(B) (A)4 2(B) (R1)5 1 3(R2) (R1)5 1 3(R2) (P) (P) Metal seal Rubber seal
3	3 position closed center (A)4 2(B) (R1)5 1 3(R2) (P)
4	3 position exhaust center (A)4 2(B) (R1)5 1 3(R2) (P)
5	3 position pressure center (A)4 2(B) (R1)5 1 3(R2) (P)
A (2)	4 position dual 3 port valve 4(A) 2(B) 1(P) 3(R)
B (2)	4 position dual 3 port valve 4(A) 2(B) 1(P) 3(R)
C (2)	4 position dual 3 port valve 4(A) 2(B) 1(P) 3(R)

Note 1) For double solenoid specification, the function symbol below is "D".
Note 2) Only rubber seal types are applicable.

Function

Symbol	Specifications
Nil	Standard type (0.4 W)
B (4)	Quick response type (0.95 W)
D (1)	2 position double (Double solenoid specifications)
K (4)	High pressure type (1 MPa, 0.95 W) [Applicable to metal seal only]
N	Negative common
R (2)	External pilot specifications

Note 1) "D" is specified for 2 position double.
Note 2) Except dual 3 port valves.
Note 3) When two or more symbols are specified, indicate them alphabetically.
Note 4) Function combination of "B" and "K" is not possible.

CE/UKCA-compliant

Nil	—
Q	CE/UKCA-compliant

With/Without manifold block

Nil	M	MB (Note)
Without manifold block 	With manifold block 	With manifold block, built-in back pressure check valve
• When ordering with manifolds • When only valves are required.		For adding stations

Note) Since 4 port specification valves (5 (R1) and 3 (R2) are common) are used, back pressure cannot be prevented with dual 3 port valves.

Port plug mounting port

Nil	None
A	Port 4(A)
B	Port 2(B)

Cylinder port

Symbol	Port size	Port location	
C3	One-touch fitting for ø3.2	Side ported 	
C4	One-touch fitting for ø4		
C6	One-touch fitting for ø6		
M5	M5 thread	Top (1) ported 	
L3	One-touch fitting for ø3.2		
L4	One-touch fitting for ø4		
L6	One-touch fitting for ø6		
L5	M5 thread		

Note 1) Can be changed to side ported configuration.
Note 2) Refer to page 700 for the inch-size One-touch fittings.

Manual override

Nil	B
Non-locking push type (Tool required) 	Locking type (Tool required)

Electrical entry

L	LO
Plug connector type With 300 mm lead wire 	Plug connector type without connector
For F, P, J kit manifolds (Note)	

Note) Indicate "LO" when ordering centralized wiring type manifolds, F, P, and J kits, since the lead wire will be attached to the manifold side.

Rated voltage

5	24 VDC
6	12 VDC

Note) Light/surge voltage suppressor is built-in.

SQ1000 Series

Manifold Options

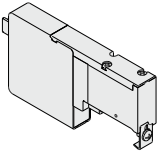
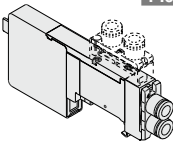
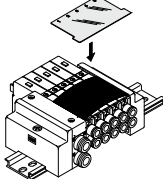
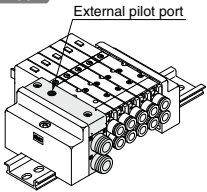
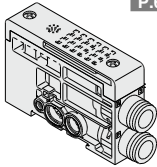
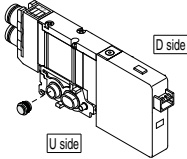
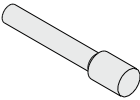
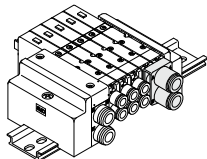
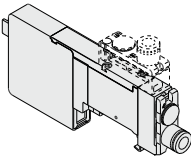
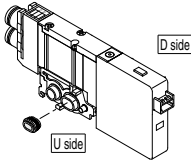
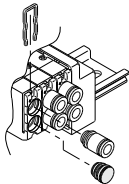
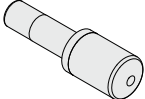
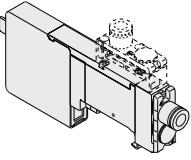
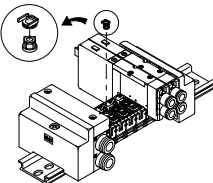
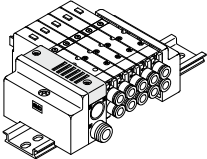
<p>Blanking plate SSQ1000-10A-4 P.688</p> 	<p>Individual SUP/EXH spacer SSQ1000-PR1-4-C₆L₆ P.689</p> 	<p>Name plate (-N) SSQ1000-N3-n P.691</p> 	<p>External pilot specifications (-R) P.692</p>  <p>External pilot port</p>																																							
<p>SUP/EXH block SSQ1000-PR-4-C8 (-S) P.688</p> 	<p>SUP block plate SSQ1000-B-P P.690</p>  <p>D side U side</p>	<p>Blanking plug KQ2P-23/04/06/08 P.691</p> 	<p>Dual flow fitting SSQ1000-52A-C₈N₉ P.692</p> 																																							
<p>Individual SUP spacer SSQ1000-P-4-C₆L₆ P.688</p> 	<p>EXH block plate SSQ1000-B-R P.690</p>  <p>D side U side</p>	<p>Port plug VVQZ100-CP P.691</p> 	<p>Silencer (For EXH port) P.692</p> 																																							
<p>Individual EXH spacer SSQ1000-R-4-C₆L₆ P.689</p> 	<p>Back pressure check valve (-B) SSQ1000-BP P.690</p> 	<p>Built-in silencer, direct exhaust (-S) P.691</p> 	<p>Special wiring specifications (-K) P.698</p> <p>D-sub connector</p> <table border="0"> <tr> <td>Terminal no.</td> <td></td> <td></td> </tr> <tr> <td>1 station</td> <td>~</td> <td>SOLA 1 (-)</td> </tr> <tr> <td>2 stations</td> <td>~</td> <td>SOLA 14 (-)</td> </tr> <tr> <td>3 stations</td> <td>~</td> <td>SOLA 2 (-)</td> </tr> <tr> <td>4 stations</td> <td>~</td> <td>SOLA 15 (-)</td> </tr> <tr> <td>5 stations</td> <td>~</td> <td>SOLA 3 (-)</td> </tr> <tr> <td>6 stations</td> <td>~</td> <td>SOLA 4 (-)</td> </tr> <tr> <td>7 stations</td> <td>~</td> <td>SOLA 17 (-)</td> </tr> <tr> <td>8 stations</td> <td>~</td> <td>SOLA 18 (-)</td> </tr> <tr> <td></td> <td>~</td> <td>SOLA 5 (-)</td> </tr> <tr> <td></td> <td>~</td> <td>SOLA 6 (-)</td> </tr> <tr> <td></td> <td>~</td> <td>SOLA 19 (-)</td> </tr> <tr> <td></td> <td>~</td> <td>COM. 13 (+)</td> </tr> </table> <p>Connector terminal no.</p> <p>Although the standard products come with double wiring, mixed single and double wiring is available upon request.</p>	Terminal no.			1 station	~	SOLA 1 (-)	2 stations	~	SOLA 14 (-)	3 stations	~	SOLA 2 (-)	4 stations	~	SOLA 15 (-)	5 stations	~	SOLA 3 (-)	6 stations	~	SOLA 4 (-)	7 stations	~	SOLA 17 (-)	8 stations	~	SOLA 18 (-)		~	SOLA 5 (-)		~	SOLA 6 (-)		~	SOLA 19 (-)		~	COM. 13 (+)
Terminal no.																																										
1 station	~	SOLA 1 (-)																																								
2 stations	~	SOLA 14 (-)																																								
3 stations	~	SOLA 2 (-)																																								
4 stations	~	SOLA 15 (-)																																								
5 stations	~	SOLA 3 (-)																																								
6 stations	~	SOLA 4 (-)																																								
7 stations	~	SOLA 17 (-)																																								
8 stations	~	SOLA 18 (-)																																								
	~	SOLA 5 (-)																																								
	~	SOLA 6 (-)																																								
	~	SOLA 19 (-)																																								
	~	COM. 13 (+)																																								

How to Order Manifold Assembly

Example: D-sub connector kit, with cable (3 m)

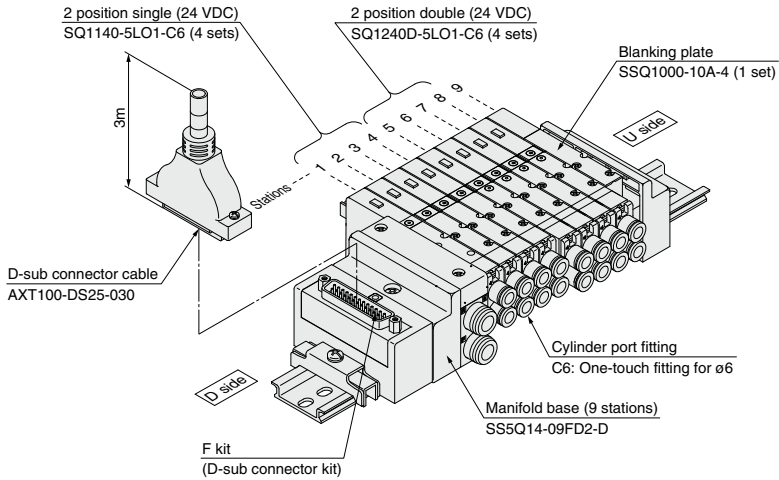

SS5Q14-09FD2-D 1 set (F kit 9-station manifold base)

* SQ1140-5LO1-C6 4 sets (2 position single)

* SQ1240D-5LO1-C6 4 sets (2 position double)

* SSQ1000-10A-4 1 set (Blanking plate)

↳ The asterisk denotes the symbol for assembly. Prefix it to the part nos. of the solenoid valve, etc.

Add the valve and option part numbers in order starting from the first station on the D side.
When entry of part numbers becomes complicated, indicate on the manifold specification sheet.

SQ1000 Series

Valve Specifications

Model

Series	Type of actuation	Seal	Model	Flow rate characteristics (1)						Response time (ms) (2)		Weight (g)	
				1→4/2 (P→A/B)			4→5 (A→R1)			Standard (0.4 W)	Quick response (0.95 W)		
				C [dm ³ /(s·bar)]	b	Cv	C [dm ³ /(s·bar)]	b	Cv				
SQ1000	2 position	Single	Metal seal	SQ1140	0.62	0.10	0.14	0.63	0.11	0.14	26 or less	12 or less	80
			Rubber seal	SQ1141	0.79	0.20	0.19	0.80	0.20	0.19	24 or less	15 or less	80
		Double	Metal seal	SQ1240D	0.62	0.10	0.14	0.63	0.11	0.14	13 or less	10 or less	95
			Rubber seal	SQ1241D	0.79	0.20	0.19	0.80	0.20	0.19	20 or less	15 or less	95
	3 position	Closed center	Metal seal	SQ1340	0.58	0.12	0.14	0.63	0.11	0.14	44 or less	29 or less	100
			Rubber seal	SQ1341	0.64	0.20	0.15	0.58	0.26	0.16	39 or less	25 or less	100
		Exhaust center	Metal seal	SQ1440	0.58	0.12	0.14	0.60	0.14	0.14	44 or less	29 or less	100
			Rubber seal	SQ1441	0.64	0.20	0.15	0.80	0.20	0.19	39 or less	25 or less	100
		Pressure center	Metal seal	SQ1540	0.62	0.12	0.14	0.63	0.14	0.14	44 or less	29 or less	100
			Rubber seal	SQ1541	0.79	0.21	0.19	0.59	0.20	0.14	39 or less	25 or less	100
	4 position	Dual 3 port valve	Rubber seal	SQ1641	0.59	0.28	0.15	0.59	0.28	0.15	27 or less	14 or less	95

Note 1) Values for the cylinder port size of C6, CYL → Values of EXH. Flow rate characteristics of 2 → 3 (B → R2) declines about 30% of 4 → 5 (A → R1).
 Note 2) Based on JIS B 8419:2010. (Values with a supply pressure of 0.5 MPa and light/surge voltage suppressor. Values fluctuate depending on the pressure and air quality.)

Specifications

Valve specifications	Valve construction	Metal seal	Rubber seal	
	Fluid	Air		
Maximum operating pressure	0.7 MPa (High pressure type (3) : 1.0 MPa)			
Min. operating pressure	Single	0.1 MPa	0.15 MPa	
	Double (Double solenoid)	0.1 MPa	0.1 MPa	
	3 position	0.1 MPa	0.2 MPa	
	4 position	—	0.15 MPa	
Ambient and fluid temperature	-10 to 50°C (1)			
Lubrication	Not required			
Pilot valve manual override	Push type/Locking type (Tool required)			
Vibration/Impact resistance (2)	30/150 m/s ²			
Protection structure	Dust tight			
Solenoid specifications	Coil rated voltage	12 VDC, 24 VDC		
	Allowable voltage fluctuation	±10% of rated voltage		
	Coil insulation type	Equivalent to class B		
	Power consumption (Current)	24 VDC	0.4 W DC (17 mA), 0.95 W DC (40 mA) (4)	
		12 VDC	0.4 W DC (34 mA), 0.95 W DC (80 mA) (4)	

Note 1) Use dry air to prevent condensation when operating at low temperatures.

Note 2) Vibration resistance: No malfunction occurred in a one-sweep test between 45 and 2000 Hz. Test was performed at both energized and de-energized states in the axial direction and at the right angles to the main valve and armature. (Values at the initial period)

Impact resistance: No malfunction occurred when it is tested with a drop tester in the axial direction and at the right angles to the main valve and armature in both energized and deenergized states every once for each condition.

Note 3) Metal seal type only.
 Note 4) Value for quick response, high pressure type.



Symbol

2 position single

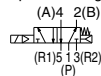

2 position double (Double solenoid)

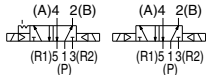

Metal seal Rubber seal

3 position closed center



3 position pressure center

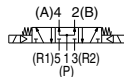

4 position dual 3 port valve (B)

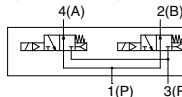

3 position exhaust center



4 position dual 3 port valve (A)

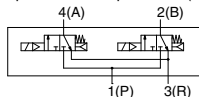

4 position dual 3 port valve (C)

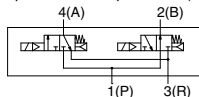

Manifold Specifications

Base model	Porting specifications			Applicable solenoid valve	Type of connection		Applicable stations (3)	5-station weight (4) (g)	Addition per station (4) (g)
	Port size (1)								
	1(P), 3(R)	Port location	4(A), 2(B) Port size						
SS5Q14-□□-□	C8 (For ø8)	Side	C3 (For ø3.2) C4 (For ø4) C6 (For ø6) M5 (M5 thread)	SQ1□40 SQ1□41	F kit: D-sub connector		1 to 12 stations	420	20
			Option Built-in silencer, (direct exhaust)		Top (2)	L3 (For ø3.2) L4 (For ø4) L6 (For ø6) L5 (M5 thread)	P kit: Flat ribbon cable	26P 20P	1 to 12 stations 1 to 9 stations
	C kit: Connector kit						1 to 24 stations	460	35

Note 1) One-touch fittings in inch sizes are also available. For details, refer to page 700.

Note 2) Can be changed to side ported configuration.

Note 3) An optional specification for special wiring is available to increase the maximum number of stations. Refer to page 698 for details.

Note 4) Except valves. For valve weight, refer to page 668.

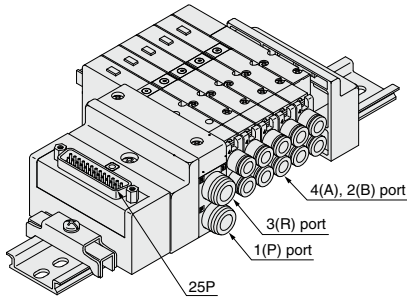

F kit

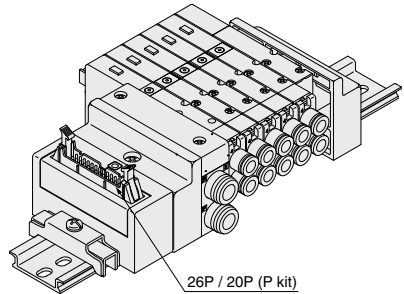

P kit

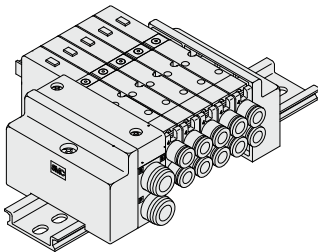

C kit

SQ1000 Series

F Kit (D-sub Connector Kit)

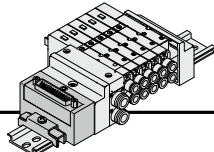

- The D-sub connector reduces installation labor for electrical connections.
- Using the D-sub connector (25P), conforming to MIL standard permits the use of connectors put on the market and gives a wide interchangeability.
- Top or side receptacle position can be selected in accordance with the available mounting space.

Manifold Specifications

Series	Port location	Porting specifications		Maximum number of stations (24 as a semi-standard)
		1(P), 3(R)	4(A), 2(B)	
SQ1000	Side, Top	C8	C3, C4, C6, M5	12 stations

D-sub connector (25 Pins)

015
AXT100-DS25-030
050

(The D-sub connector cable assemblies can be ordered with manifolds. Refer to "How to Order Manifold.")

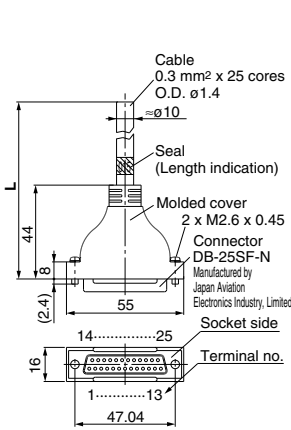

Cable assembly ●

D-sub Connector Cable Assembly Terminal No.

Terminal number	Lead wire color	Dot marking
1	Black	None
2	Brown	None
3	Red	None
4	Orange	None
5	Yellow	None
6	Pink	None
7	Blue	None
8	Purple	White
9	Gray	Black
10	White	Black
11	White	Red
12	Yellow	Red
13	Orange	Red
14	Yellow	Black
15	Pink	Black
16	Blue	White
17	Purple	None
18	Gray	None
19	Orange	Black
20	Red	White
21	Brown	White
22	Pink	Red
23	Gray	Red
24	Black	White
25	White	None

D-sub Connector Cable Assembly

Cable length (L)	Assembly part no.	Note
1.5 m	AXT100-DS25-015	Cable
3 m	AXT100-DS25-030	0.3 mm ² x 25 cores
5 m	AXT100-DS25-050	25 cores

* For other commercial connectors, use a 25 pins type with female connector conforming to MIL-C-24308.

* Cannot be used for movable wiring.
* Lengths other than the above are also available. Please contact SMC for details.

Electrical Characteristics

Item	Property
Conductor resistance Ω/km, 20°C	65 or less
Withstand voltage VAC, 1 min.	1000
Insulation resistance MΩ/km, 20°C	5 or more

Note) The minimum bending inner radius of D-sub connector cable is 20 mm.

Connector manufacturers' example

- Fujitsu Limited
- Japan Aviation Electronics Industry, Limited
- J.S.T. Mfg. Co., Ltd.
- HIROSE ELECTRIC CO., LTD.

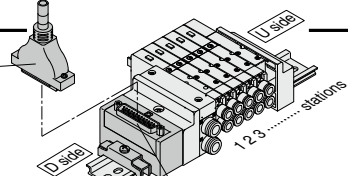

Electrical Wiring Specifications

D-sub connector

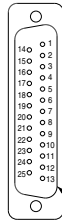

As the standard electrical wiring specifications, double wiring (connected to SOL. A and SOL. B) is adopted for the internal wiring of each station for 12 stations or less, regardless of valve and option types. Mixed single and double wiring is available as an option. For details, refer to page 698.

* Valves are numbered from the D side.

Connector terminal no.

D-sub connector assembly wire colors (AXT100-DS25-015-050)

Terminal no.	Polarity	Lead wire color	Dot marking
1 station	SOL_a 1 (-)	(+) Black	None
	SOL_b 14 (-)	(+) Yellow	Black
2 stations	SOL_a 2 (-)	(+) Brown	None
	SOL_b 15 (-)	(+) Pink	Black
3 stations	SOL_a 3 (-)	(+) Red	None
	SOL_b 16 (-)	(+) Blue	White
4 stations	SOL_a 4 (-)	(+) Orange	None
	SOL_b 17 (-)	(+) Purple	None
5 stations	SOL_a 5 (-)	(+) Yellow	None
	SOL_b 18 (-)	(+) Gray	None
6 stations	SOL_a 6 (-)	(+) Pink	None
	SOL_b 19 (-)	(+) Orange	Black
7 stations	SOL_a 7 (-)	(+) Blue	None
	SOL_b 20 (-)	(+) Red	White
8 stations	SOL_a 8 (-)	(+) Purple	White
	SOL_b 21 (-)	(+) Brown	White
9 stations	SOL_a 9 (-)	(+) Gray	Black
	SOL_b 22 (-)	(+) Pink	Red
10 stations	SOL_a 10 (-)	(+) White	Black
	SOL_b 23 (-)	(+) Gray	Red
11 stations	SOL_a 11 (-)	(+) White	Red
	SOL_b 24 (-)	(+) Black	White
12 stations	SOL_a 12 (-)	(+) Yellow	Red
	SOL_b 25 (-)	(+) White	None
	COM. 13 (+)	(-) Orange	Red

Positive common Negative common specifications specifications

Note) When using the negative common specifications, use valves for negative common.

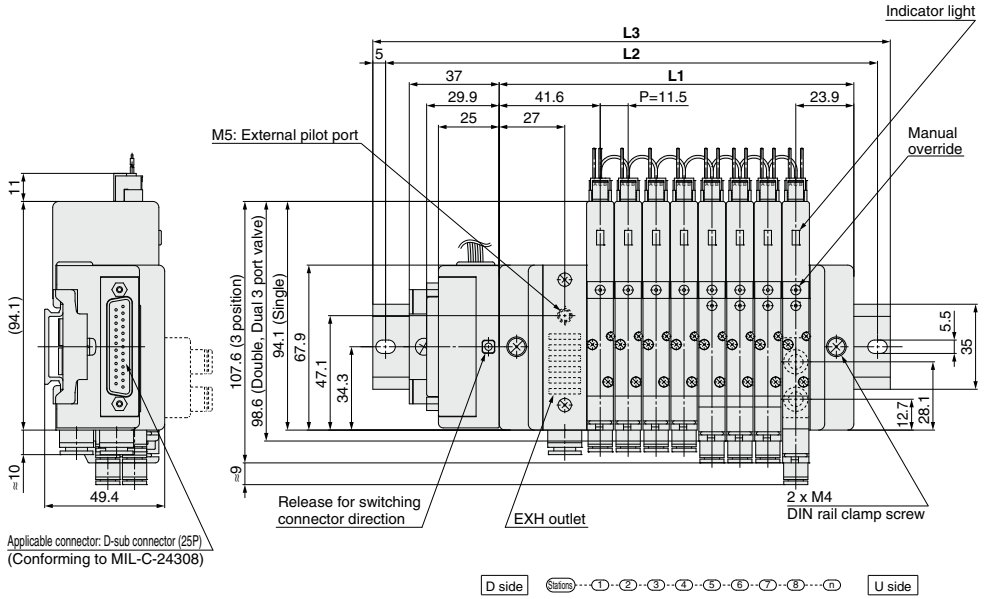

Applicable connector: D-sub connector (25P)
(Conforming to MIL-C-24308)

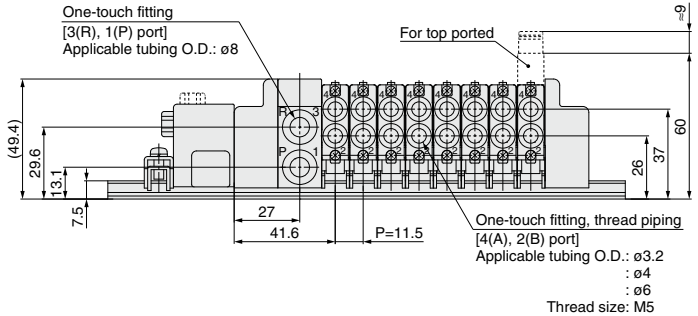

Dimensions

Formula: $L1 = 11.5n + 54$ n: Stations (Maximum 24 stations)

L	n	1	2	3	4	5	6	7	8	9	10	11	12	13	14	15	16	17	18	19	20	21	22	23	24
L1		65.5	77	88.5	100	111.5	123	134.5	146	157.5	169	180.5	192	203.5	215	226.5	238	249.5	261	272.5	284	295.5	307	318.5	330
L2		125	137.5	150	162.5	175	187.5	200	212.5	225	237.5	250	262.5	275	287.5	300	312.5	325	337.5	350	362.5	375	375	375	387.5
L3		135.5	148	160.5	173	185.5	198	210.5	223	235.5	248	260.5	273	285.5	298	310.5	323	335.5	348	360.5	373	385.5	385.5	385.5	398

SQ1000 Series

P Kit (Flat Ribbon Cable Connector)

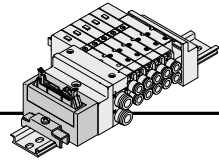

- Simplification and labor savings for wiring work can be achieved by using a MIL type for the electrical connection.
- Using the connector for flat ribbon cable (26P, 20P) conforming to MIL standard permits the use of connectors put on the market and gives a wide interchangeability.
- Top or side receptacle position can be selected in accordance with the available mounting space.

Manifold Specifications

Series	Porting specifications Port location	Port size		Maximum number of stations
		1(P), 3(R)	4(A), 2(B)	
SQ1000	Side, Top	C8	C3, C4, C6, M5	12 stations (24 as a semi-standard)

Flat Ribbon Cable (26 Pins, 20 Pins)

Cable assembly ●

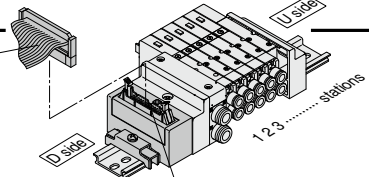

AXT100-FC ¹/₂₆ - ²/₂₀ - ³/₃

(Type 26P flat ribbon cable connector assemblies can be ordered with manifolds. Refer to "How to Order manifold".)

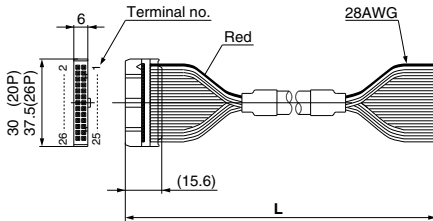

Flat Ribbon Cable Connector Assembly

Cable length (L)	Assembly part no.	
	26P	20P
1.5 m	AXT100-FC26-1	AXT100-FC20-1
3 m	AXT100-FC26-2	AXT100-FC20-2
5 m	AXT100-FC26-3	AXT100-FC20-3

- * For other commercial connectors, use a 26 pins or 20 pins with strain relief conforming to MIL-C-83503.
- * Cannot be used for movable wiring.
- * Lengths other than the above are also available. Please contact SMC for details.

Connector manufacturers' example

- HIROSE ELECTRIC CO., LTD.
- 3M Japan Limited
- Fujitsu Limited
- Japan Aviation Electronics Industry, Limited
- J.S.T. Mfg. Co., Ltd.
- Oki Electric Cable Co., Ltd.

Electrical Wiring Specifications

Flat ribbon cable connector

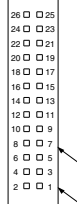

Double wiring (connected to SOL. A and SOL. B) is adopted for the internal wiring of each station, regardless of valve and option types. Mixed single and double wiring is available as an option.
For details, refer to page 698.

Connector terminal no.

Triangle mark indicator position

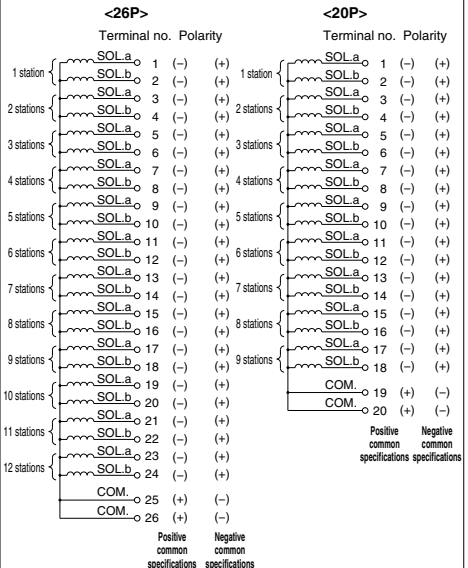

Note) When using the negative common specifications, use valves for negative common.

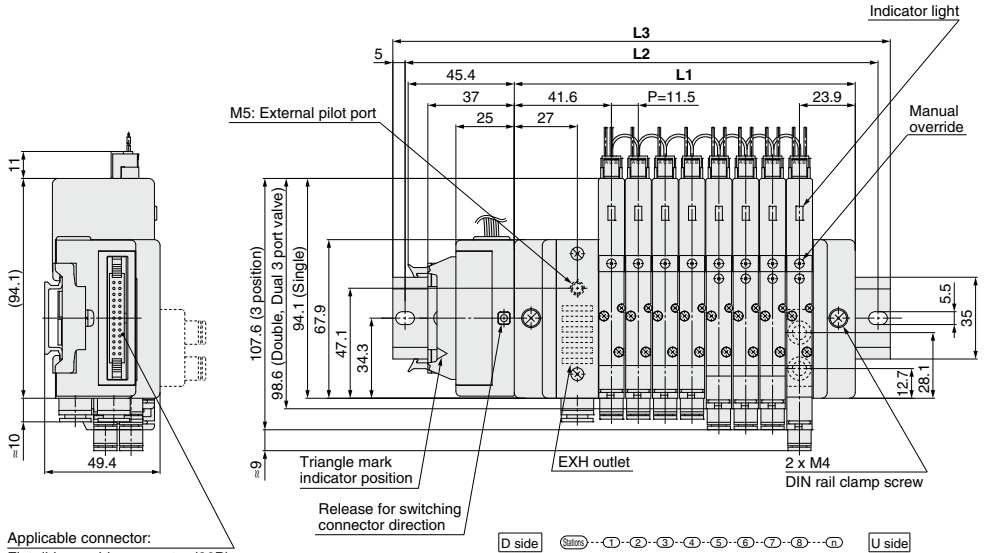

Applicable connector:
Flat ribbon cable connector (26P)
(Conforming to MIL-C-83503)

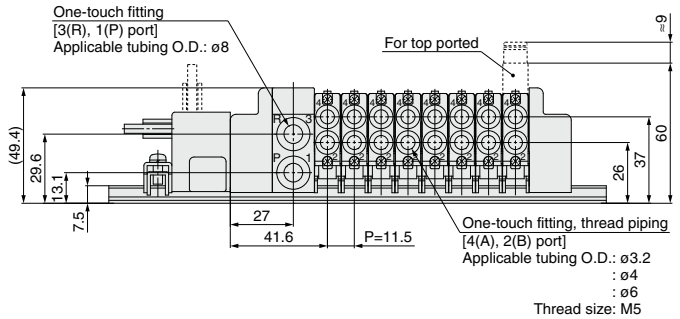

Dimensions

Formula: $L1 = 11.5n + 54$ n: Stations (Maximum 24 stations)

L	n	1	2	3	4	5	6	7	8	9	10	11	12	13	14	15	16	17	18	19	20	21	22	23	24
L1		65.5	77	88.5	100	111.5	123	134.5	146	157.5	169	180.5	192	203.5	215	226.5	238	249.5	261	272.5	284	295.5	307	318.5	330
L2		125	137.5	150	162.5	175	187.5	200	212.5	225	237.5	250	262.5	275	287.5	300	312.5	325	337.5	350	362.5	375	375	375	387.5
L3		135.5	148	160.5	173	185.5	198	210.5	223	235.5	248	260.5	273	285.5	298	310.5	323	335.5	348	360.5	373	385.5	385.5	385.5	398

SQ1000 Series

C Kit (Connector)

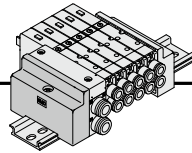

- Standard with lead wires connected to each valve individually.

Manifold Specifications

Series	Port location	Porting specifications		Maximum number of stations
		1(P), 3(R)	4(A), 2(B)	
SQ1000	Side, Top	C8	C3, C4, C6, M5	24 stations

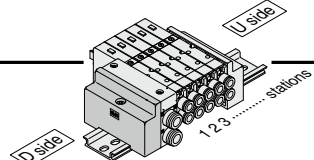

* Valves are numbered from the D side.

● Wiring Specifications: Positive Common Specifications

Since lead wires are connected to the valves as shown below, connect each wire to the power supply.

Single solenoid

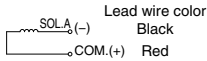

Lead wire color
Black
Red

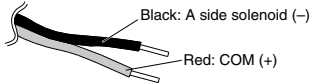

Double solenoid

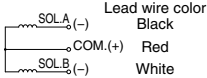

Lead wire color
Black
Red
White

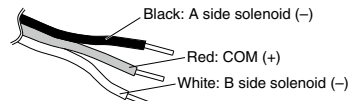

● Plug connector lead wire length

The lead wire length of the valves with lead wire is 300 mm. When ordering a lead wire length of 600 mm or longer, list the part numbers for the valve without connector and the connector assembly.
Example) For lead wire length of 1000 mm: SQ1140-5LO1-C6...3 pcs.
AXT661-14AL-10...3 pcs.

Connector Assembly Part No.

Lead wire length	Single solenoid	Double solenoid
Socket only (3 pcs.)	AXT661-12AL	
300 mm	AXT661-14AL	AXT661-13AL
600 mm	AXT661-14AL-6	AXT661-13AL-6
1000 mm	AXT661-14AL-10	AXT661-13AL-10
2000 mm	AXT661-14AL-20	AXT661-13AL-20
3000 mm	AXT661-14AL-30	AXT661-13AL-30

● Wiring Specifications: Negative Common Specifications (Semi-standard)

Since lead wires are connected to the valves as shown below, connect each wire to the power supply.

Single solenoid

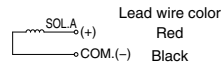

Lead wire color
Red
Black

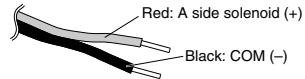

Double solenoid

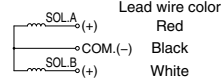

Lead wire color
Red
Black
White

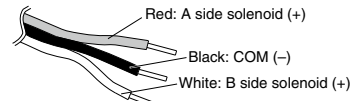

● Plug connector lead wire length

The lead wire length of the valves with lead wire is 300 mm. When ordering a lead wire length of 600 mm or longer, list the part numbers for the valve without connector and the connector assembly.
Example) For lead wire length of 1000 mm: SQ1140-5LO1-C6...3 pcs.
AXT661-14ANL-10...3 pcs.

Connector Assembly Part No.

Lead wire length	Single solenoid	Double solenoid
Socket only (3 pcs.)	AXT661-12AL	
300 mm	AXT661-14ANL	AXT661-13ANL
600 mm	AXT661-14ANL-6	AXT661-13ANL-6
1000 mm	AXT661-14ANL-10	AXT661-13ANL-10
2000 mm	AXT661-14ANL-20	AXT661-13ANL-20
3000 mm	AXT661-14ANL-30	AXT661-13ANL-30

Note) When using the negative common specifications, use valves for negative common.

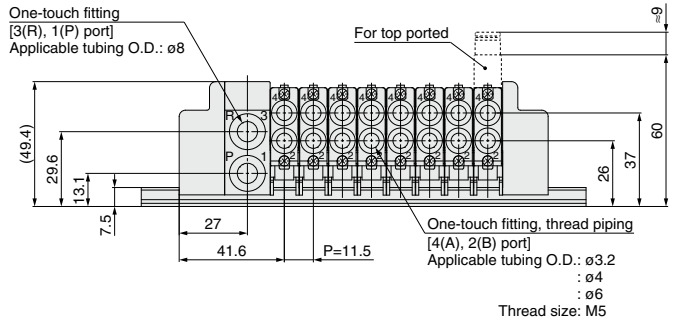
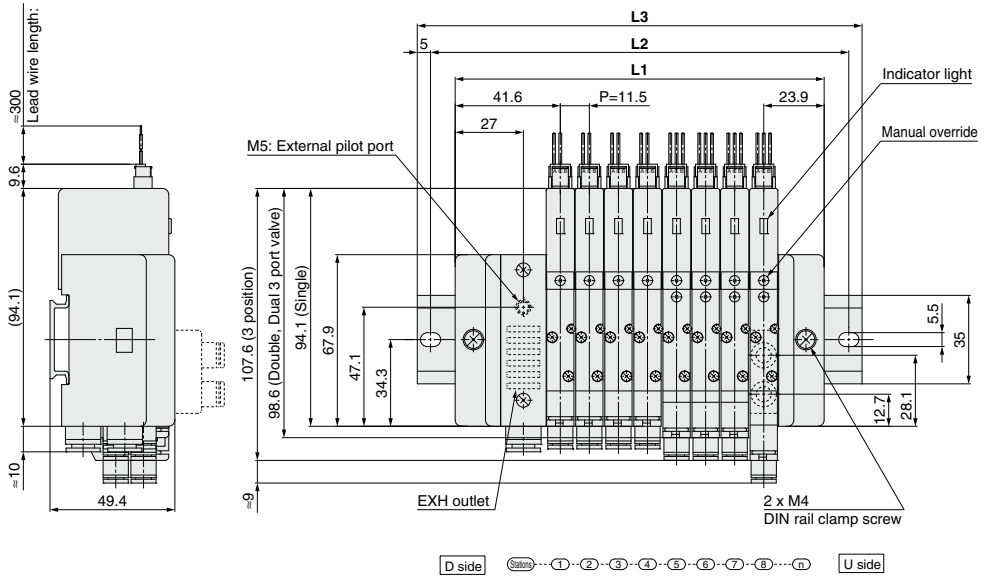

Dimensions

Formula: $L1 = 11.5n + 54$ n: Stations (Maximum 24 stations)

L	n	1	2	3	4	5	6	7	8	9	10	11	12	13	14	15	16	17	18	19	20	21	22	23	24
L1		65.5	77	88.5	100	111.5	123	134.5	146	157.5	169	180.5	192	203.5	215	226.5	238	249.5	261	272.5	284	295.5	307	318.5	330
L2		87.5	100	112.5	125	137.5	150	162.5	175	187.5	200	212.5	225	237.5	250	262.5	275	287.5	300	312.5	325	337.5	350	350	350
L3		98	110.5	123	135.5	148	160.5	173	185.5	185.5	198	210.5	223	235.5	248	260.5	273	285.5	298	310.5	323	335.5	348	360.5	360.5

Plug Lead Unit

SQ2000 Series



How to Order Manifold

SS5Q24 - **08** **FD2** - **D** □ - □ - □

Stations

01	1 station
⋮	⋮
16	16 stations

Refer to "Electrical entry" for details.

CE/UKCA-compliant

Nil	—
Q	CE/UKCA-compliant

1(P), 3(R) port size

Nil	1(P), 3(R) port, One-touch fittings for ø10
00T	1(P), 3(R) port, One-touch fittings for ø3/8"

Manifold mounting

D	DIN rail mounting type
E (Note)	Direct mounting type

(Note) Type E is only available with a C kit.
Refer to page 699 for details.

Option

Nil	None
02 to 16 (1)	DIN rail length specified
B	Back pressure check valve
K (3)	Special wiring specifications (Except double wiring)
N	With name plate (Side ported only)
R	External pilot specifications
S	Built-in silencer, direct exhaust

Note 1) Specify DIN rail length with "D□" at the end. (Enter the number of stations inside □.)
The number of stations that may be displayed is longer than the manifold number of stations. Example: -D09

Note 2) When "-B" is selected, a back pressure check valve is included in all stations of the manifold. If the back pressure check valve is used only for the station that need it, then specify the station location in the manifold specification. ("-B" is not necessary)

Note 3) Specify "-K" for wiring specification for cases below. (Except C kit)

- All single wiring
- Single and double mixed wiring.

Specify the wiring specification in the manifold specification so that the number of solenoids is the maximum number of solenoids or less. (Standard wiring specification is double wiring)

Note 4) For specifying two or more options, enter them alphabetically. Example: -BKN

* Refer to pages 693 to 700 for manifold option parts.

Electrical entry

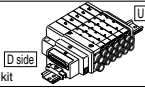
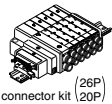
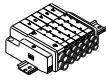
Kit type	Lead wire connector location	Cable specifications	Stations	Max. number of solenoids for special wiring specifications	Max. number of solenoids for special wiring specifications (2)	
F kit  D-sub Connector kit	D side	FD0	D-sub connector (25P) kit, without cable	1 to 12 stations (Double wiring)	16 stations	24
		FD1	D-sub connector (25P) kit, with 1.5 m cable			
		FD2	D-sub connector (25P) kit, with 3.0 m cable			
		FD3	D-sub connector (25P) kit, with 5.0 m cable			
P kit  Flat ribbon cable connector kit (26P / 20P)	D side (1)	PD0	Flat ribbon cable (26P) kit, without cable	1 to 12 stations (Double wiring)	16 stations	24
		PD1	Flat ribbon cable (26P) kit, with 1.5 m cable			
		PD2	Flat ribbon cable (26P) kit, with 3.0 m cable			
		PD3	Flat ribbon cable (26P) kit, with 5.0 m cable			
		PDC	Flat ribbon cable (20P) kit, without cable			1 to 9 stations (Double wiring)
C kit  Connector kit	C	—	Connector kit	1 to 16 stations	—	—

Note 1) Separately order the 20P type cable assembly for the P kit.

Note 2) Specify the number of the solenoid so that the maximum station number is not exceeded. (The number of solenoids are counted as: 1 for single solenoids and 2 for type 3P and 4P double solenoids.)

* Refer to page 707 for manifold spare parts.

How to Order Valves

SQ2 1 4 0 - **5 L** - **1 - C6** - - -

Seal

0	Metal seal
1	Rubber seal

Type of actuation

1	2 position single (A)4 2(B) (R1)5 1 3(R2) (P)
2	2 position double (Double solenoid) (1) (A)4 2(B) (A)4 2(B) (R1)5 1 3(R2) (R1)5 1 3(R2) (P) (P) Metal seal Rubber seal
3	3 position closed center (A)4 2(B) (R1)5 1 3(R2) (P)
4	3 position exhaust center (A)4 2(B) (R1)5 1 3(R2) (P)
5	3 position pressure center (A)4 2(B) (R1)5 1 3(R2) (P)
A (2)	4 position dual 3 port valve 4(A) 2(B) 5(R1) 1(P) 3(R2)
B (2)	4 position dual 3 port valve 4(A) 2(B) 5(R1) 1(P) 3(R2)
C (2)	4 position dual 3 port valve 4(A) 2(B) 5(R1) 1(P) 3(R2)

Note 1) For double solenoid specifications, the function symbol below is "D".
Note 2) Only rubber seal types are applicable.

Function

Symbol	Specifications
Nil	Standard type (0.4 W)
B	Quick response type (0.95 W)
D (1)	2 position double (Double solenoid specifications)
N	Negative common
R (2)	External pilot specifications

Note 1) "D" is specified for 2 position double.
Note 2) Except dual 3 port valves.
Note 3) When two or more symbols are specified, indicate them alphabetically.

CE/UKCA-compliant

Nil	—
Q	CE/UKCA-compliant

With/Without manifold block

Nil	M	MB
Without manifold block 	With manifold block 	With manifold block, built-in back pressure check valve
<ul style="list-style-type: none"> When ordering with manifolds When only valves are required. 		For adding stations

Port plug mounting port

Nil	None
A	Port 4(A)
B	Port 2(B)

Cylinder port

Symbol	Port size	Port location	
C4	One-touch fitting for ø4	Side ported	
C6	One-touch fitting for ø6		
C8	One-touch fitting for ø8		
L4	One-touch fitting for ø4	Top ported(1)	
L6	One-touch fitting for ø6		
L8	One-touch fitting for ø8		

Note 1) Can be changed to side ported configuration.
Note 2) Refer to page 700 for the inch-size One-touch fittings.

Manual override

Nil	B	D
Non-locking push type (Tool required)	Locking type (Tool required)	Slide locking type (Manual type) * Only side ported type applicable

Electrical entry

L	LO
Plug connector type With 300 mm lead wire	Plug connector type without connector
	For F, P, J kit manifolds (Note)

Note) Indicate "LO" when ordering centralized wiring type manifolds, F, P, and J kits, since the lead wire will be attached to the manifold side.

Rated voltage

5	24 VDC
6	12 VDC

Note) Light/surge voltage suppressor is built-in.

SQ2000 Series

Manifold Options

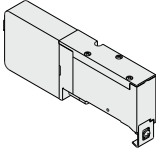
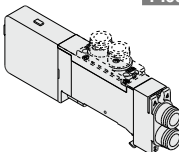
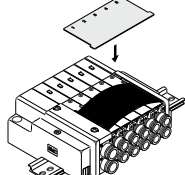
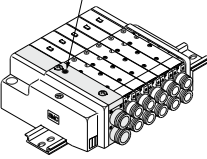
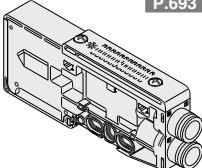
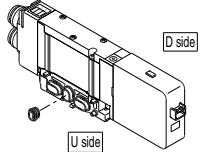
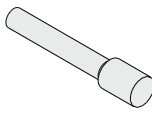
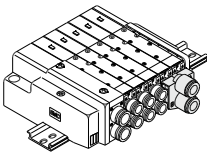
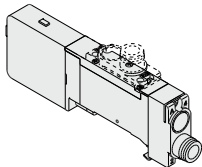
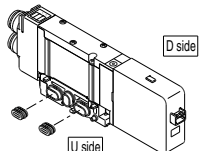
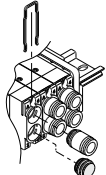
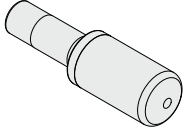
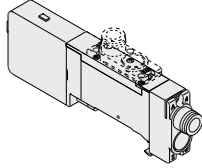
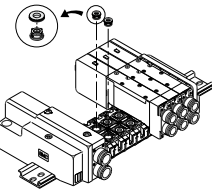
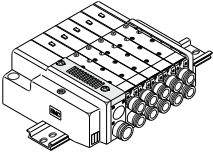
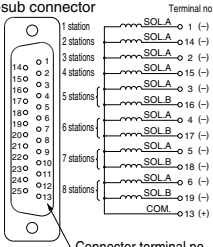
<p>Blanking plate SSQ2000-10A-4 P.693</p> 	<p>Individual SUP/EXH spacer SSQ2000-PR1-4-C⁸_{L⁸} P.694</p> 	<p>Name plate (-N) SSQ2000-N3-n P.696</p> 	<p>External pilot specifications (-R) P.697</p> <p>External pilot port</p> 
<p>SUP/EXH block SSQ2000-PR-3-C10(-S) P.693</p> 	<p>SUP block plate SSQ1000-B-R P.695</p> 	<p>Blanking plug KQ2P-04/06/08/10 P.696</p> 	<p>Dual flow fitting SSQ2000-52A-C¹⁰_{N11} P.697</p> 
<p>Individual SUP spacer SSQ2000-P-4-C⁸_{L⁸} P.693</p> 	<p>EXH block plate SSQ2000-B-R P.695</p> 	<p>Port plug VVQZ2000-CP P.696</p> 	<p>Silencer (For EXH port) P.697</p> 
<p>Individual EXH spacer SSQ2000-R-4-C⁸_{L⁸} P.694</p> 	<p>Back pressure check valve (-B) SSQ2000-BP P.695</p> 	<p>Built-in silencer, direct exhaust (-S) P.696</p> 	<p>Special wiring specifications (-K) P.698</p> <p>D-sub connector</p>  <p>Terminal no.</p> <p>Connector terminal no.</p> <p>Although the standard products come with double wiring, mixed single and double wiring is available upon request.</p>

How to Order Manifold Assembly

Example: D-sub connector kit, with cable (3 m)

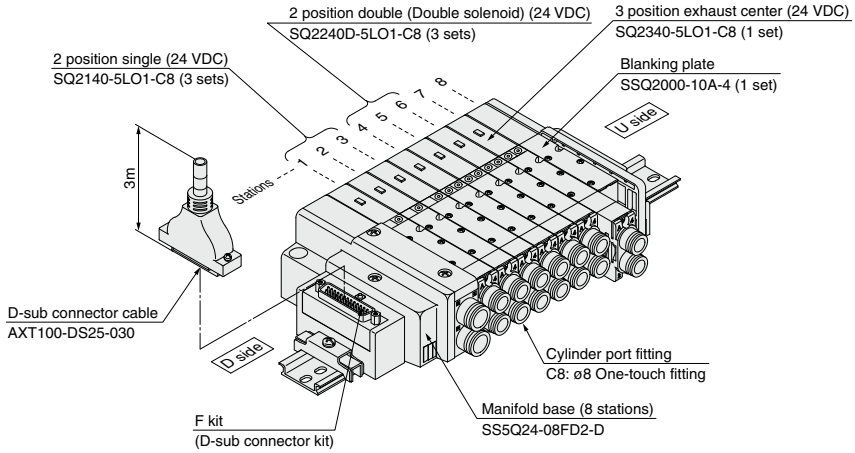

- SS5Q24-08FD2-D 1 set (F kit 8-station manifold base)
 * SQ2140-5LO1-C8 3 sets (2 position single)
 * SQ2240D-5LO1-C8 ... 3 sets (2 position double)
 * SQ2340-5LO1-C8 1 set (3 position exhaust center)
 * SSQ2000-10A-4 1 set (Blanking plate)

↳ The asterisk denotes the symbol for assembly. Prefix it to the part nos. of the solenoid valve, etc.

Add the valve and option part numbers in order starting from the first station on the D side.
 When entry of part numbers becomes complicated, indicate on the manifold specification sheet.

SQ2000 Series

Valve Specifications

Model

Series	Type of actuation	Seal	Model	Flow rate characteristics (1)						Response time (ms) (2)		Weight (g)	
				1→4/2 (P→A/B)			4/2→5/3 (A/B→R1/R2)			Standard (0.4 W)	Quick response (0.95 W)		
				C [dm ³ /(s·bar)]	b	Cv	C [dm ³ /(s·bar)]	b	Cv				
SQ2000	2 position	Single	Metal seal	SQ2140	2.2	0.17	0.51	2.4	0.14	0.57	35 or less	20 or less	145
			Rubber seal	SQ2141	2.3	0.17	0.51	3.1	0.18	0.71	31 or less	24 or less	140
		Double	Metal seal	SQ2240D	2.2	0.17	0.51	2.4	0.14	0.57	20 or less	15 or less	160
			Rubber seal	SQ2241D	2.3	0.17	0.51	3.1	0.18	0.71	26 or less	20 or less	155
	3 position	Closed center	Metal seal	SQ2340	1.9	0.17	0.46	2.1	0.15	0.47	56 or less	37 or less	180
			Rubber seal	SQ2341	1.9	0.17	0.46	1.8	0.29	0.45	44 or less	34 or less	175
		Exhaust center	Metal seal	SQ2440	1.9	0.17	0.46	2.4	0.14	0.55	56 or less	37 or less	180
			Rubber seal	SQ2441	1.9	0.17	0.46	3.1	0.14	0.58	44 or less	34 or less	175
		Pressure center	Metal seal	SQ2540	2.3	0.17	0.51	2.1	0.18	0.47	56 or less	37 or less	180
			Rubber seal	SQ2541	2.5	0.17	0.56	1.8	0.30	0.47	44 or less	34 or less	175
	4 position	Dual 3 port valve	Rubber seal	SQ2641	1.5	0.17	0.40	1.5	0.17	0.40	34 or less	19 or less	155

Note 1) Values for the top ported cylinder port size of C8, CYL → Values of EXH. The side ported type will be about 10% less.

Note 2) Based on JIS B 8419:2010. (Values with a supply pressure of 0.5 MPa and light/surge voltage suppressor. Values fluctuate depending on the pressure and air quality.)

Specifications

Valve specifications	Valve construction	Metal seal	Rubber seal	
	Fluid	Air		
	Maximum operating pressure	0.7 MPa		
	Min. operating pressure	Single	0.1 MPa	0.15 MPa
		Double (Double solenoid)	0.1 MPa	0.1 MPa
		3 position	0.1 MPa	0.2 MPa
		4 position	—	0.15 MPa
	Ambient and fluid temperature	-10 to 50°C (1)		
	Lubrication	Not required		
	Pilot valve manual override	Push type (Tool required)/Locking type (Tool required) Slide locking type (Manual type)		
Vibration/Impact resistance (2)	30/150 m/s ²			
Protection structure	Dust tight			
Solenoid specifications	Coil rated voltage	12 VDC, 24 VDC		
	Allowable voltage fluctuation	±10% of rated voltage		
	Coil insulation type	Equivalent to class B		
	Power consumption (Current)	24 VDC	0.4 W DC (17 mA), 0.95 W DC (40 mA) (3)	
12 VDC		0.4 W DC (34 mA), 0.95 W DC (80 mA) (3)		

Note 1) Use dry air to prevent condensation when operating at low temperatures.

Note 2) Vibration resistance: No malfunction occurred in a one-sweep test between 45 and 2000 Hz. Test was performed at both energized and de-energized states in the axial direction and at the right angles to the main valve and armature. (Values at the initial period)

Impact resistance: No malfunction occurred when it is tested with a drop tester in the axial direction and at the right angles to the main valve and armature in both energized and deenergized states every once for each condition.

Note 3) Value for quick response type.



Symbol

2 position single

(A)4 2(B)

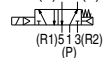

(R1)5 1 3(R2)

(P)

2 position double (Double solenoid)

(A)4 2(B) (A)4 2(B)

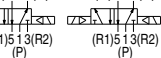

(R1)5 1 3(R2) (R1)5 1 3(R2)

(P)

3 position closed center

(A)4 2(B)

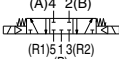

(R1)5 1 3(R2)

(P)

3 position exhaust center

(A)4 2(B)

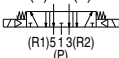

(R1)5 1 3(R2)

(P)

3 position pressure center

(A)4 2(B)

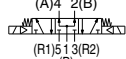

(R1)5 1 3(R2)

(P)

4 position dual 3 port valve (A)

4(A) 2(B)

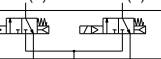

5(R1) 1(P)

4 position dual 3 port valve (B)

4(A) 2(B)

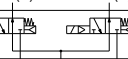

5(R1) 1(P)

4 position dual 3 port valve (C)

4(A) 2(B)

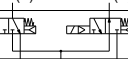

5(R1) 1(P)

Manifold Specifications

Base model	Porting specifications			Applicable solenoid valve	Type of connection		Applicable stations ⁽³⁾	5-station weight ⁽⁴⁾ (g)	Addition per station ⁽⁴⁾ (g)
	Port size ⁽¹⁾		Port location						
	1(P), 3(R)	4(A), 2(B)							
SS5Q24-□□-□	C10 (For ø10)	Side	C4 (For ø4) C6 (For ø6) C8 (For ø8)	SQ2□40 SQ2□41	F kit: D-sub connector		1 to 12 stations	580	35
			Option Built-in silencer, (direct exhaust)		Top ⁽²⁾	L4 (For ø4) L6 (For ø6) L8 (For ø8)	P kit: Flat ribbon cable	26P	1 to 12 stations
	20P	1 to 9 stations							
					C kit: Connector kit		1 to 16 stations	620	50

Note 1) One-touch fittings in inch sizes are also available. For details, refer to page 700.

Note 2) Can be changed to side ported configuration.

Note 3) An optional specification for special wiring is available to increase the maximum number of stations. Refer to page 698 for details.

Note 4) Except valves. For valve weight, refer to page 680.

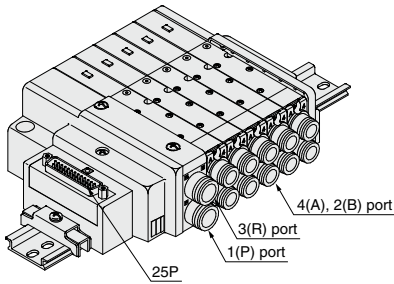

F kit

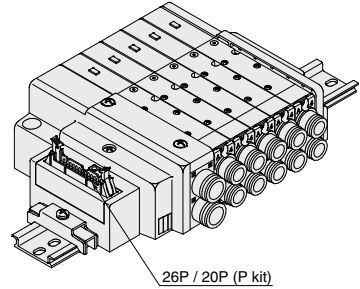

P kit

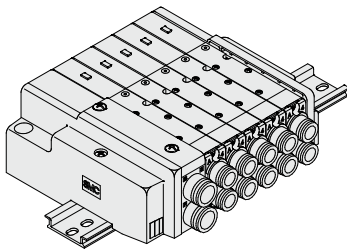

C kit

SQ2000 Series

F Kit (D-sub Connector Kit)

- The D-sub connector reduces installation labor for electrical connections.
- Using the D-sub connector (25P), conforming to MIL standard permits the use of connectors put on the market and gives a wide interchangeability.
- Top or side receptacle position can be selected in accordance with the available mounting space.

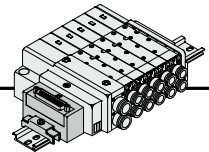

Manifold specifications

Series	Porting specifications		Maximum number of stations
	Port location	Port size	
SQ2000	Side, Top	1(P), 3(R)	12 stations (16 as a semi-standard)
		4(A), 2(B)	

D-sub Connector (25 Pins)

Cable assembly

015
AXT100-DS25-030
050

(The D-sub connector cable assemblies can be ordered with manifolds. Refer to "How to Order Manifold.")

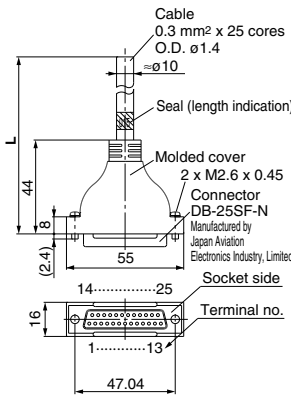

D-sub Connector Cable Assembly Terminal No.

Terminal number	Lead wire color	Dot marking
1	Black	None
2	Brown	None
3	Red	None
4	Orange	None
5	Yellow	None
6	Pink	None
7	Blue	None
8	Purple	White
9	Gray	Black
10	White	Black
11	White	Red
12	Yellow	Red
13	Orange	Red
14	Yellow	Black
15	Pink	Black
16	Blue	White
17	Purple	None
18	Gray	None
19	Orange	Black
20	Red	White
21	Brown	White
22	Pink	Red
23	Gray	Red
24	Black	White
25	White	None

D-sub Connector Cable Assembly

Cable length (L)	Assembly part no.	Note
1.5 m	AXT100-DS25-015	Cable
3 m	AXT100-DS25-030	0.3 mm ² x 25 cores
5 m	AXT100-DS25-050	25 cores

* For other commercial connectors, use a 25 pins type with female connector conforming to MIL-C-24308.

* Cannot be used for movable wiring.

* Lengths other than the above are also available. Please contact SMC for details.

Electrical Characteristics

Item	Property
Conductor resistance Ω/km, 20°C	65 or less
Withstand voltage VAC, 1 min.	1000
Insulation resistance MΩ/km, 20°C	5 or more

Note) The minimum bending inner radius of D-sub connector cable is 20 mm.

Connector manufacturers' example

- Fujitsu Limited
- Japan Aviation Electronics Industry, Limited
- J.S.T. Mfg. Co., Ltd.
- HIROSE ELECTRIC CO., LTD.

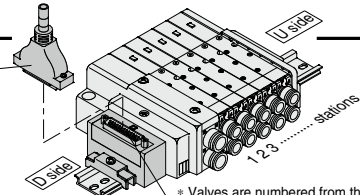

Electrical Wiring Specifications

D-sub connector

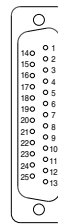

As the standard electrical wiring specifications, double wiring (connected to SOL. A and SOL. B) is adopted for the internal wiring of each station for 12 stations or less, regardless of valve and option types. Mixed single and double wiring is available as an option. For details, refer to page 698.

Connector terminal no.

D-sub connector assembly wire colors (AXT100-DS25-015/050)

	Terminal no.	Polarity	Lead wire color	Dot marking
1 station	SOL_a 1	(-)	(+)	Black None
	SOL_b 14	(-)	(+)	Yellow Black
2 stations	SOL_a 2	(-)	(+)	Brown None
	SOL_b 15	(-)	(+)	Pink Black
3 stations	SOL_a 3	(-)	(+)	Red None
	SOL_b 16	(-)	(+)	Blue White
4 stations	SOL_a 4	(-)	(+)	Orange None
	SOL_b 17	(-)	(+)	Purple None
5 stations	SOL_a 5	(-)	(+)	Yellow None
	SOL_b 18	(-)	(+)	Gray None
6 stations	SOL_a 6	(-)	(+)	Pink None
	SOL_b 19	(-)	(+)	Orange Black
7 stations	SOL_a 7	(-)	(+)	Blue None
	SOL_b 20	(-)	(+)	Red White
8 stations	SOL_a 8	(-)	(+)	Purple White
	SOL_b 21	(-)	(+)	Brown White
9 stations	SOL_a 9	(-)	(+)	Gray Black
	SOL_b 22	(-)	(+)	Pink Red
10 stations	SOL_a 10	(-)	(+)	White Black
	SOL_b 23	(-)	(+)	Gray Red
11 stations	SOL_a 11	(-)	(+)	White Red
	SOL_b 24	(-)	(+)	Black White
12 stations	SOL_a 12	(-)	(+)	Yellow Red
	SOL_b 25	(-)	(+)	White None
	COM.	(+)	(-)	Orange Red

Positive common specifications Negative common specifications

Note) When using the negative common specifications, use values for negative common.

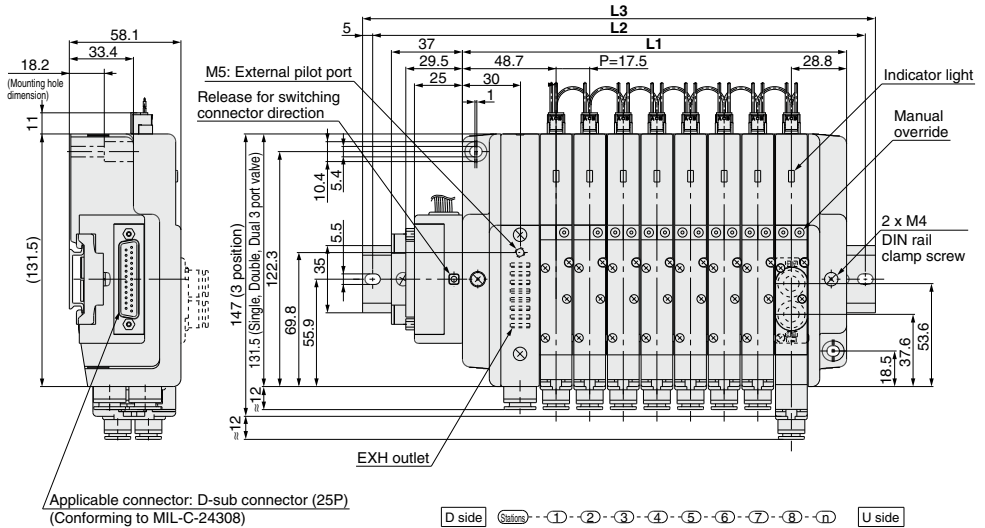

Dimensions

Formula: $L1 = 17.5n + 60$ n: Stations (Maximum 16 stations)

L	n	1	2	3	4	5	6	7	8	9	10	11	12	13	14	15	16
L1		77.5	95	112.5	130	147.5	165	182.5	200	217.5	235	252.5	270	287.5	305	322.5	340
L2		137.5	162.5	175	187.5	212.5	225	250	262.5	275	300	312.5	337.5	350	362.5	387.5	400
L3		148	173	185.5	198	223	235.5	260.5	273	285.5	310.5	323	348	360.5	373	398	410.5

SQ2000 Series

P Kit (Flat Ribbon Cable Connector)

- Simplification and labor savings for wiring work can be achieved by using a MIL type for the electrical connection.
- Using the connector for flat ribbon cable (26P, 20P) conforming to MIL standard permits the use of connectors up on the market and gives a wide interchangeability.
- Top or side receptacle position can be selected in accordance with the available mounting space.

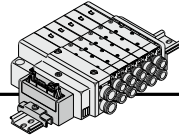

Manifold Specifications

Series	Porting specifications		Maximum number of stations
	Port location	Port size	
SQ2000	Side, Top	1(P), 3(R)	C4, C6, C8
		4(A), 2(B)	

Flat Ribbon Cable (26 Pins, 20 Pins)

AXT100-FC ²⁰/₂₆ ¹/₂ ³

(Type 26P flat ribbon cable connector assemblies can be ordered with manifolds. Refer to "How to Order manifold".)

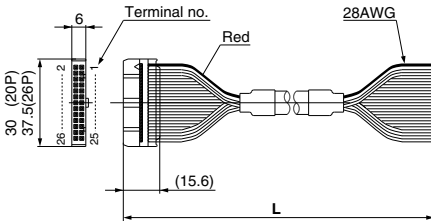

Flat Ribbon Cable Connector Assembly

Cable length (L)	Assembly part no.	
	26P	20P
1.5 m	AXT100-FC26-1	AXT100-FC20-1
3 m	AXT100-FC26-2	AXT100-FC20-2
5 m	AXT100-FC26-3	AXT100-FC20-3

- * For other commercial connectors, use a 26 pins or 20 pins with strain relief conforming to MIL-C-83503.
- * Cannot be used for movable wiring.
- * Lengths other than the above are also available. Please contact SMC for details.

Connector manufacturers' example

- HIROSE ELECTRIC CO., LTD.
- 3M Japan Limited
- Fujitsu Limited
- Japan Aviation Electronics Industry, Limited
- J.S.T. Mfg. Co., Ltd.
- Oki Electric Cable Co., Ltd.

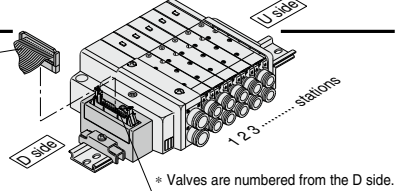

Electrical Wiring Specifications

Flat ribbon cable connector

Double wiring (connected to SOL. A and SOL. B) is adopted for the internal wiring of each station, regardless of valve and option types. Mixed single and double wiring is available as an option. For details, refer to page 698.

Connector terminal no.

Triangle mark indicator position

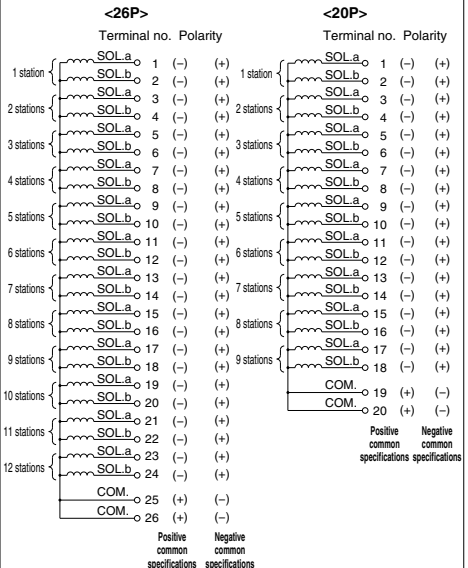

Note) When using the negative common specifications, use valves for negative common.

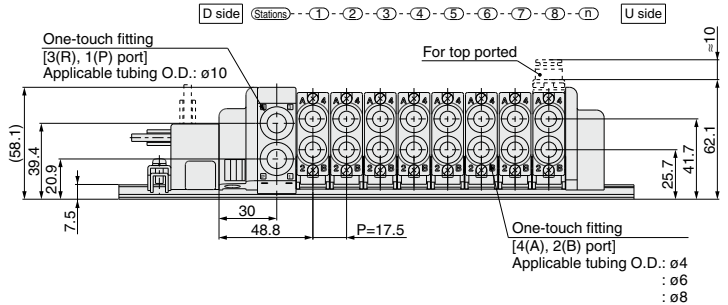
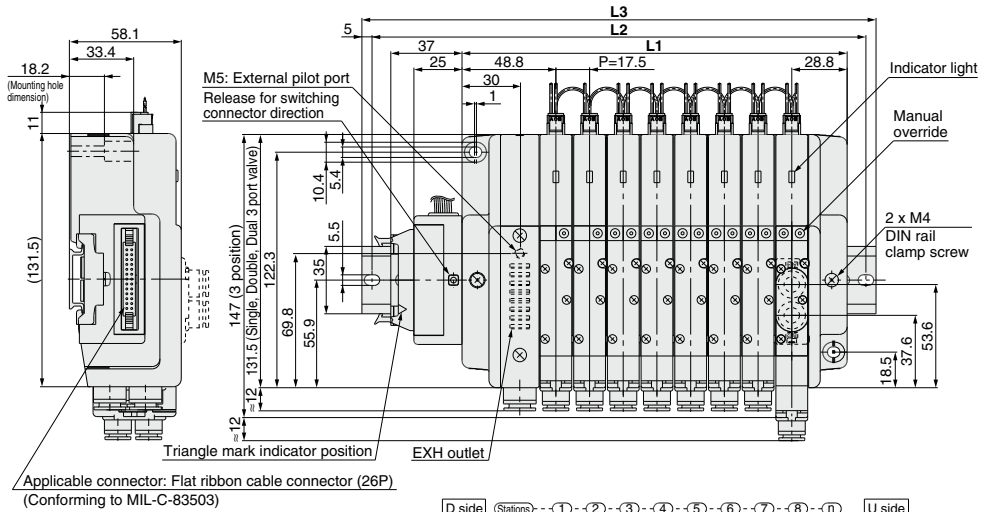

Dimensions

Formula: $L1 = 17.5n + 60$ n: Stations (Maximum 16 stations)

L	n	1	2	3	4	5	6	7	8	9	10	11	12	13	14	15	16
L1		77.5	95	112.5	130	147.5	165	182.5	200	217.5	235	252.5	270	287.5	305	322.5	340
L2		137.5	162.5	175	187.5	212.5	225	250	262.5	275	300	312.5	337.5	350	362.5	387.5	400
L3		148	173	185.5	198	223	235.5	260.5	273	285.5	310.5	323	348	360.5	373	398	410.5

SQ2000 Series

C Kit (Connector)

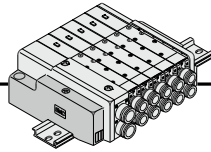

- Standard with lead wires connected to each valve individually.

Manifold Specifications

Series	Porting specifications		Maximum number of stations
	Port location	Port size	
SQ2000	Side, Top	1(P), 3(R)	4(A), 2(B)
		C10	C4, C6, C8

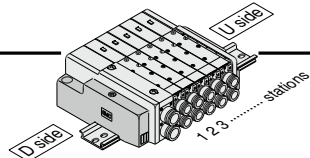

* Valves are numbered from the D side.

● Wiring Specifications: Positive Common Specifications

Since lead wires are connected to the valves as shown below, connect each wire to the power supply.

Single solenoid

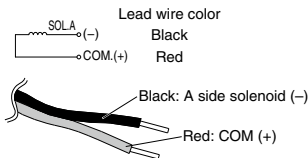

Double solenoid

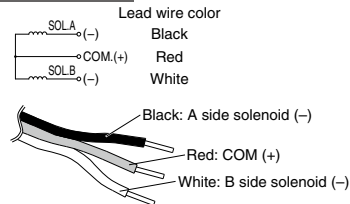

● Plug connector lead wire length

The lead wire length of the valves with lead wire is 300 mm. When ordering a lead wire length of 600 mm or longer, list the part numbers for the valve without connector and the connector assembly.
Example) For lead wire length of 1000 mm: SQ2140N-5LO1-C6...3 pcs.
AXT661-14AL-10...3 pcs.

Connector Assembly Part No.

Lead wire length	Single solenoid	Double solenoid
Socket only (3 pcs.)	AXT661-12AL	
300 mm	AXT661-14AL	AXT661-13AL
600 mm	AXT661-14AL-6	AXT661-13AL-6
1000 mm	AXT661-14AL-10	AXT661-13AL-10
2000 mm	AXT661-14AL-20	AXT661-13AL-20
3000 mm	AXT661-14AL-30	AXT661-13AL-30

● Wiring Specifications: Negative Common Specifications (Semi-standard)

Since lead wires are connected to the valves as shown below, connect each wire to the power supply.

Single solenoid

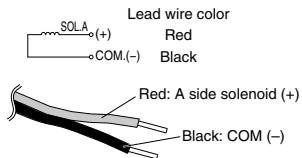

Double solenoid

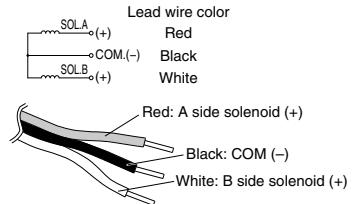

● Plug connector lead wire length

The lead wire length of the valves with lead wire is 300 mm. When ordering a lead wire length of 600 mm or longer, list the part numbers for the valve without connector and the connector assembly.
Example) For lead wire length of 1000 mm: SQ2140N-5LO1-C6...3 pcs.
AXT661-14ANL-10...3 pcs.

Connector Assembly Part No.

Lead wire length	Single solenoid	Double solenoid
Socket only (3 pcs.)	AXT661-12AL	
300 mm	AXT661-14ANL	AXT661-13ANL
600 mm	AXT661-14ANL-6	AXT661-13ANL-6
1000 mm	AXT661-14ANL-10	AXT661-13ANL-10
2000 mm	AXT661-14ANL-20	AXT661-13ANL-20
3000 mm	AXT661-14ANL-30	AXT661-13ANL-30

Note) When using the negative common specifications, use valves for negative common.

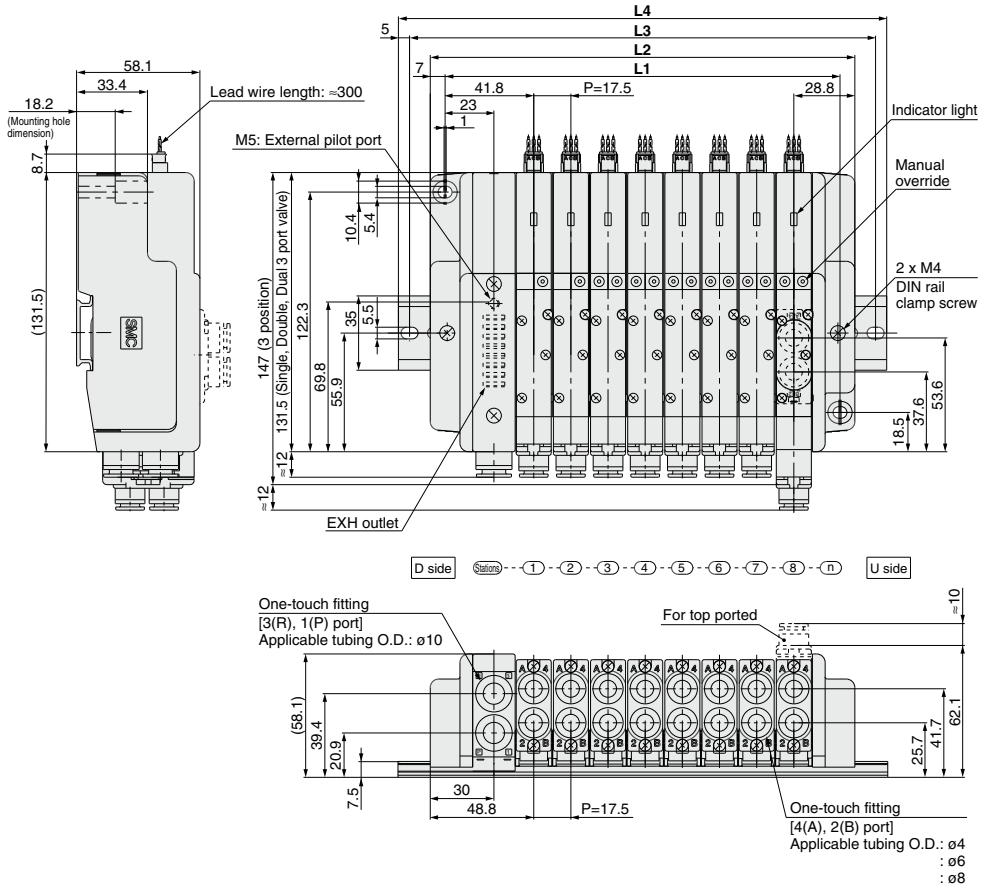

Dimensions

Formula: $L1 = 17.5n + 46$, $L2 = 17.5n + 60$ n: Stations (Maximum 16 stations)

L	n	1	2	3	4	5	6	7	8	9	10	11	12	13	14	15	16
L1		63.5	81	98.5	116	133.5	151	168.5	186	203.5	221	238.5	256	273.5	291	308.5	326
L2		77.5	95	112.5	130	147.5	165	182.5	200	217.5	235	252.5	270	287.5	305	322.5	340
L3		100	125	137.5	150	175	187.5	212.5	225	237.5	262.5	275	300	312.5	325	350	362.5
L4		110.5	135.5	148	160.5	185.5	198	223	235.5	248	273	285.5	310.5	323	335.5	360.5	373

SQ1000 Series

Manifold Option Parts for SQ1000

Blanking plate

SSQ1000-10A-4

It is used by attaching on the manifold block for being prepared for removing a valve for maintenance reasons or planning to mount a spare valve, etc.

* Electrical wiring is connected to the manifold station with the blanking plate.

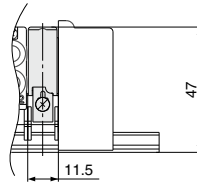
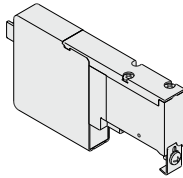

Symbol



SUP/EXH block

SSQ1000-PR-4-C8-□

Port size

C8	One-touch fittings for ø8
N9	One-touch fittings for ø5/16"

Option

Nil	Standard
R	External pilot specifications
S	Built-in silencer

Note) When specifying both options, indicate "RS".

* Specify the spacer mounting position on the manifold specification sheet.

For standard type manifolds, the SUP/EXH block is mounted on the D side.

It is added to the manifold to increase SUP/EXH capacity.

* The number of SUP/EXH blocks that can be added is limited to two sets, one between manifold stations and another on the U side of the manifold, due to the length of the lead wire.

* SUP/EXH blocks are not included in the number of manifold stations.

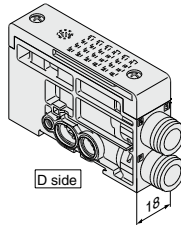

Description/Model	Stations				
	1	2	3	4	5
Valve	Single	Single	Single	Single	Single
Option				●	
SUP/EXH block SSQ1000-PR-4-C8-□					

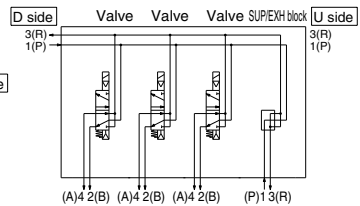

Individual SUP spacer

SSQ1000-P-4-C6

Port size

Side ported	C6	One-touch fittings for ø6
	N7	One-touch fittings for ø1/4"
Top ported	L6	One-touch fittings for ø6
	LN7	One-touch fittings for ø1/4"

This is used as a supply port for different pressures when using different pressures in the same manifold (for one station). Both sides of the station which is used with supply pressure from the individual SUP spacer are shut off. (Refer to application example.)

* Specify the spacer mounting position and SUP passage shut off positions on the manifold specification sheet. Up to two shut off positions can be specified per unit.

(Two pieces of SUP block plate that shut off the supply pressure are included with the individual SUP spacer, therefore, it is not necessary to order them separately.)

* No electrical wiring is connected to the manifold station with the individual SUP spacer. When the wiring needs to be connected to the stations with the individual SUP spacer mounted, specify it on the manifold specification sheet.

* By changing the fitting shown in the drawing and the block plates, the spacer's specification can be changed later (from the individual SUP spacer to the individual EXH spacer).

* The number of spacers is not limited when ordered with the manifold. However, when adding individual for F, P, and J kits, it is limited to two units, one between manifold stations and another on the U side, due to the length of the lead wire.

* Model no. with manifold block:

SSQ1000-P-4-C6-M

Side ported

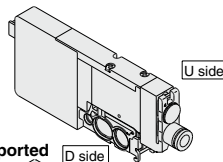

Top ported

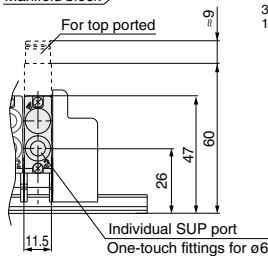
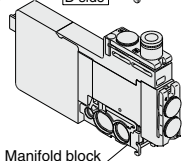

Description/Model	Stations				
	1	2	3	4	5
Valve	Single	Single	Single	Single	Single
Option			●	●	
Individual SUP spacer SSQ1000-P-4-C6					
SUP shut off position: Please specify.					

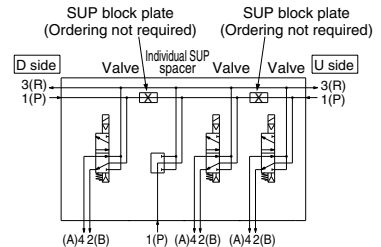

Individual EXH spacer

SSQ1000-R-4-C6

Port size

Side ported	C6	One-touch fittings for $\phi 6$
Top ported	N7	One-touch fittings for $\phi 1/4"$
Side ported	L6	One-touch fittings for $\phi 6$
Top ported	LN7	One-touch fittings for $\phi 1/4"$

This is used to exhaust an individual valve when the exhaust from a valve interferes with other stations in the circuit (used for one station). Both sides of the station which is to be individually exhausted are shut off. (Refer to application example.)

* Specify the spacer mounting position and EXH passage shut off positions on the manifold specification sheet. Up to two shut off positions can be specified per unit.

(Two pieces of EXH block plate that shut off the exhaust are included with the individual EXH spacer, therefore, it is not necessary to order them separately.)

* No electrical wiring is connected to the manifold station with the individual EXH spacer.

When the wiring needs to be connected to the stations with the individual EXH spacer mounted, specify it on the manifold specification sheet.

* By changing the fitting shown in the drawing and the block plates, the spacer's specification can be changed later (from the individual EXH spacer to the individual SUP spacer).

* The number of spacers is not limited when ordered with the manifold. However, when adding individual for F, P, and J kits, it is limited to two units, one between manifold stations and another on the U side, due to the length of the lead wire.

* Model no. with manifold block:
SSQ1000-R-4-C6-M
L6-M

Side ported

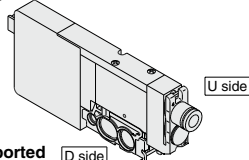

Top ported

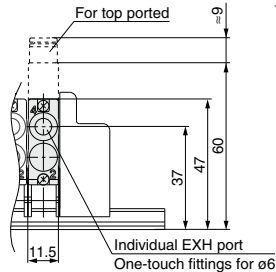
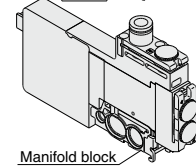

Description/Model	Stations				
	1	2	3	4	5
Valve	Single	<input checked="" type="checkbox"/>	<input checked="" type="checkbox"/>	<input checked="" type="checkbox"/>	<input checked="" type="checkbox"/>
Option	Individual EXH spacer SSQ1000-R-4-C6	<input checked="" type="checkbox"/>	<input checked="" type="checkbox"/>	<input type="checkbox"/>	<input type="checkbox"/>
	EXH shut off position: Please specify.	<input checked="" type="checkbox"/>	<input checked="" type="checkbox"/>	<input type="checkbox"/>	<input type="checkbox"/>

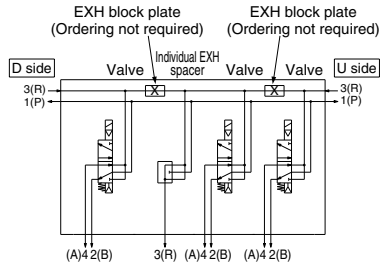

Individual SUP/EXH spacer

SSQ1000-PR1-4-C6

Port size

Side ported	C6	One-touch fittings for $\phi 6$
Top ported	N7	One-touch fittings for $\phi 1/4"$
Side ported	L6	One-touch fittings for $\phi 6$
Top ported	LN7	One-touch fittings for $\phi 1/4"$

This has both functions of the individual SUP and EXH spacers above.

(Refer to application example.)

* Specify the spacer mounting position and SUP and EXH passage shut off positions on the manifold specification sheet. Up to two shut off positions each for SUP and EXH can be specified per unit.

(Two pieces each of block plate that shut off the SUP and EXH passages are included with the individual SUP/EXH spacer, therefore, it is not necessary to order them separately.)

* No electrical wiring is connected to the manifold station with the individual SUP/EXH spacer.

When the wiring needs to be connected to the stations with the individual SUP/EXH spacer mounted, specify it on the manifold specification sheet.

* By changing the fitting shown in the drawing and the block plates, the spacer's specification can be changed later.

* The number of spacers is not limited when ordered with the manifold. However, when adding individual for F, P, and J kits, it is limited to two units, one between manifold stations and another on the U side, due to the length of the lead wire.

* Model no. with manifold block:
SSQ1000-PR1-4-C6-M
L6-M

* Do not install any back pressure check valve on the manifold station, on which the spacer is to be mounted. When installing the back pressure check valve on other manifold station, be sure to specify the manifold station position on the manifold specification sheet instead of ordering by specifying the manifold option symbol "B".

Side ported

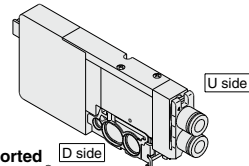

Top ported

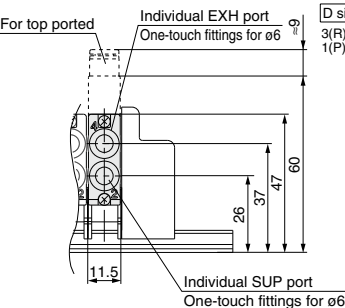
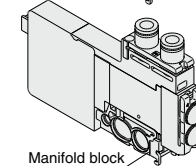

Description/Model	Stations				
	1	2	3	4	5
Valve	Single	<input checked="" type="checkbox"/>	<input checked="" type="checkbox"/>	<input checked="" type="checkbox"/>	<input checked="" type="checkbox"/>
Option	Individual SUP/EXH spacer SSQ1000-PR1-4-C6	<input checked="" type="checkbox"/>	<input checked="" type="checkbox"/>	<input type="checkbox"/>	<input type="checkbox"/>
	SUP shut off position: Please specify.	<input checked="" type="checkbox"/>	<input checked="" type="checkbox"/>	<input type="checkbox"/>	<input type="checkbox"/>
	EXH shut off position: Please specify.	<input checked="" type="checkbox"/>	<input checked="" type="checkbox"/>	<input type="checkbox"/>	<input type="checkbox"/>

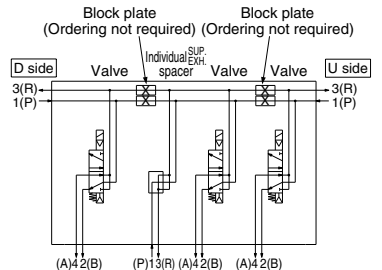

SQ1000 Series

Manifold Option Parts for SQ1000

SUP block plate

SSQ1000-B-P

When supplying two different pressures, high and low, to one manifold, this is used between stations with different pressures. Also, it is used with an individual SUP spacer to shut off the air supply.

* Specify the station position on the manifold specification sheet.

<Block indication label>

When using block plates for SUP passage, indication label for confirmation of the blocking position from outside is attached. (One label of each)

* When ordering a block plate for SUP incorporated with the manifold, a block indication label is attached to the manifold.

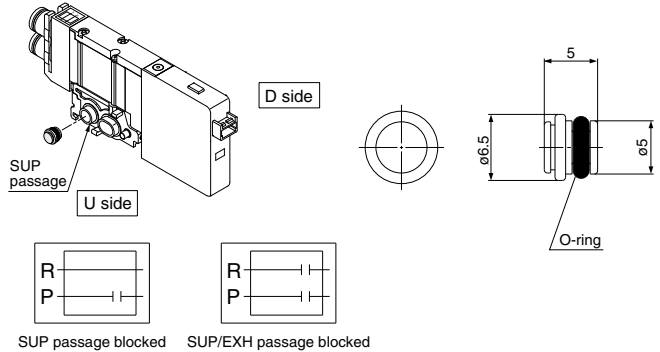

EXH block plate

SSQ1000-B-R

When the exhaust from a valve interferes with other stations in the circuit, this is used between stations to separate exhausts. Also, it is used with an individual EXH spacer to shut off the exhaust of individual valves.

* Specify the station position on the manifold specification sheet.

* Be sure to discharge the exhaust inside the EXH passage from the R port of the SUP/EXH block, etc. so that the exhaust pressure is not sealed.

<Block indication label>

When using block plates for EXH passage, indication label for confirmation of the blocking position from outside is attached. (One label of each)

* When ordering a block plate for EXH incorporated with the manifold, a block indication label is attached to the manifold.

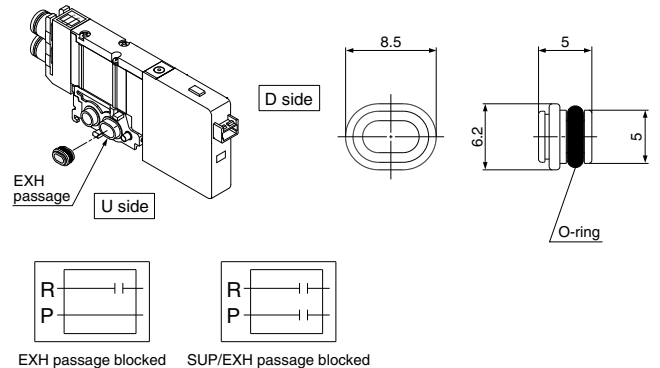

Back pressure check valve [-B]

SSQ1000-BP

It prevents cylinder malfunction caused by other valve exhaust. Insert it into R (EXH) port on the manifold side of a valve which is affected. It is effective when a single action cylinder is used or an exhaust center type solenoid valve is used.

* When a check valve for back pressure prevention is desired, and is to be installed only in certain manifold stations, clearly write the part number and specify the number of stations on the manifold specification sheet.

* When ordering this option incorporated with a manifold, suffix "-B" to the end of the manifold part number.

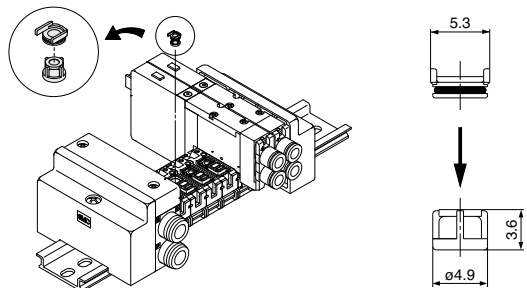

⚠ Caution

1. The back pressure check valve assembly is assembly parts with a check valve structure. However, as slight air leakage is allowed for the back pressure, take care the exhaust air will not be restricted at the exhaust port.
2. When a back pressure check valve is mounted, the effective area of the valve will decrease by about 20%.
3. Since 4 port specification valves (5 (R1) and 3 (R2) are common) are used, back pressure cannot be prevented with dual 3 port valves.

Name plate [-N]

SSQ1000-N3-Stations (1 to maximum)

It is a transparent resin plate for placing a label that indicates solenoid valve function, etc.

Insert it into the groove on the side of the end plate and bend it as shown in the figure. Also, the plate is difficult to bend for manifolds with only a few stations, therefore, remove the silencer cover to install it.

* When ordering this option incorporated with a manifold, suffix "-N" to the end of the manifold part number.

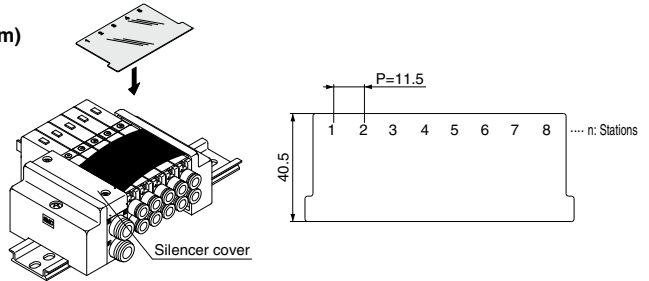

Blanking plug (For One-touch fitting)

23
KQ2P-04
06
08

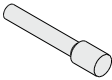

It is inserted into an unused cylinder port and SUP/EXH ports.

Purchasing order is available in units of 10 pieces.

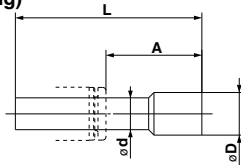

Dimensions

Applicable fittings size ød	Model	A	L	D
3.2	KQ2P-23	16	31.5	5
4	KQ2P-04	16	32	6
6	KQ2P-06	18	35	8
8	KQ2P-08	20.5	39	10

Port plug

VVQZ100-CP

The plug is used to block the cylinder port when using a 5-port valve as a 3-port valve.

* Add "A" or "B" at the end of the valve part number when ordering with valves.

Example) SQ1141-5L1-C6-A (N.O. specifications)

↓ 4 (A) port plug

Example) SQ1141-5L1-C6-B (N.C. specifications)

↓ 2 (B) port plug

Example) SQ1141-5L1-C6-B-M

(B port plug with manifold block)

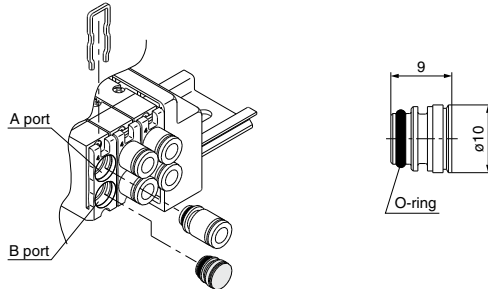

Direct EXH outlet, built-in silencer [-S]

This is a type with an exhaust port atop the manifold end plate. The built-in silencer exhibits an excellent noise suppression effect. (Noise reduction: 30 dB)

Note) A large quantity of drainage generated in the air source results in exhaust of air together with drainage.

* When ordering this option incorporated with a manifold, suffix "-S" to the end of the manifold part number.

* For precautions on handling and how to replace elements, refer to page 711.

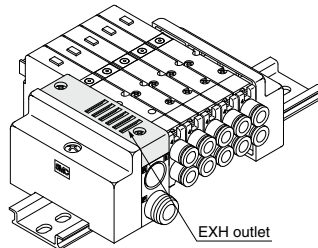

SQ1000 Series

Manifold Option Parts for SQ1000

External pilot specifications [-R]

This can be used when the air pressure is 0.1 to 0.2 MPa lower than the minimum operating pressure of the solenoid valves or used for vacuum specifications.

Add "R" to the part numbers of manifolds and valves to indicate the external pilot specification. An M5 port will be installed on the top side of the manifold's SUP/EXH block.

- How to order valves (Example)
SQ1140 **R** -5L1-C6

↓ External pilot specifications

- How to order manifold (Example)

* Indicate "R" for an option.

SSSQ14-08FD1-**DR**

↓ External pilot specifications

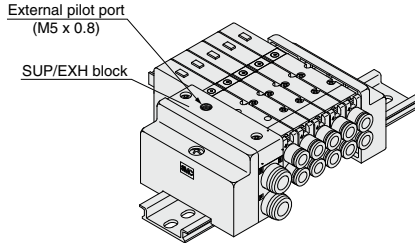

Note 1) Not applicable for dual 3 port valves.

Note 2) Valves with the external pilot specifications have a pilot EXH with individual exhaust specifications and EXH can be pressurized. However, the pressure supplied from EXH should be 0.4 MPa or lower.

Dual flow fitting

SSQ1000-52A-**C8**

Port size	
C8	ø8
N9	ø5/16"

To drive a large bore cylinder, two valve stations are operated simultaneously to double the air flow. This fitting is used on the cylinder ports in this situation. Available sizes are ø8 and ø5/16" One-touch fitting.

* When ordering with valves, specify the valve part number without One-touch fitting and list the dual flow fitting part number.

Example) Valve part number (without One-touch fitting part number)

SQ1141-5L1-**C0**..... 2 sets

* SSSQ1000-52A-**C8**..... 1 set

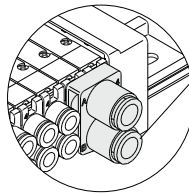

C8: ø8 One-touch fitting
N9: ø5/16" One-touch fitting

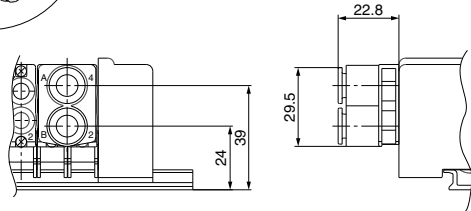

Silencer (For EXH port)

This is inserted into the centralized type EXH port (One-touch fitting).

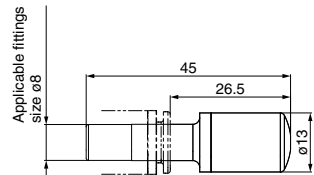
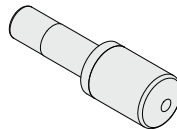

Specifications

Series	Model	Effective area (mm ²) (Cv factor)	Noise reduction (dB)
SQ1000	AN15-C08	20 (1.1)	30

Manifold Option Parts for SQ2000

Blanking plate

SSQ2000-10A-4

It is used by attaching on the manifold block for being prepared for removing a valve for maintenance reasons or planning to mount a spare valve, etc.

* Electrical wiring is connected to the manifold station with the blanking plate.

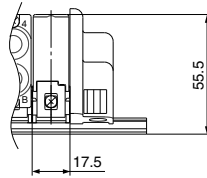
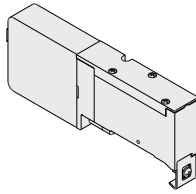

Symbol



SUP/EXH block

SSQ2000-PR-3-C10-□

Port size

C8	One-touch fittings for ø8
C10	One-touch fittings for ø10
N9	One-touch fittings for ø5/16"
N11	One-touch fittings for ø3/8"

(Note) When specifying both options, indicate "RS".

* Specify the spacer mounting position on the manifold specification sheet.

For standard type manifolds, the SUP/EXH block is mounted on the D side.

It is added to the manifold to increase SUP/EXH capacity.

* The number of SUP/EXH blocks that can be added is limited to two sets, one between manifold stations and another on the U side of manifold, due to the length of the lead wire.

* SUP/EXH blocks are not included in the number of manifold stations.

Option

N11	Standard
R	External pilot specifications
S	Built-in silencer

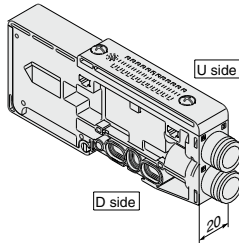

Description/Model	Stations			
	1	2	3	4
Valve	Single	●	●	●
Option	SUP/EXH block SSQ2000-PR-3-C10-□			●

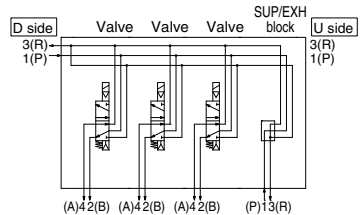

Individual SUP spacer

SSQ2000-P-4-C8

Port size

Side ported	C8	One-touch fittings for ø8
Top ported	N9	One-touch fittings for ø5/16"
Top ported	L8	One-touch fittings for ø8
Top ported	LN9	One-touch fittings for ø5/16"

This is used as a supply port for different pressures when using different pressures in the same manifold (for one station).

Both sides of the station which is used with supply pressure from the individual SUP spacer shut off. (Refer to application example.)

* Specify the spacer mounting position and SUP passage shut off positions on the manifold specification sheet. Up to two shut off positions can be specified per unit.

(Two pieces of SUP block plate that shut off the supply pressure are included with the individual SUP spacer, therefore, it is not necessary to order them separately.)

* No electrical wiring is connected to the manifold station with the individual SUP spacer. When the wiring needs to be connected to the stations with the individual SUP spacer mounted, specify it on the manifold specification sheet.

* By changing the fitting shown in the drawing and the block plates, the spacer's specification can be changed later (from the individual SUP spacer to the individual EXH spacer).

* The number of spacers is not limited when ordered with the manifold. However, when adding individual for F, P, and J kits, it is limited to two units, one between manifold stations and another on the U side, due to the length of the lead wire.

* Model no. with manifold block:
SSQ2000-P-4-C8-M

Side ported

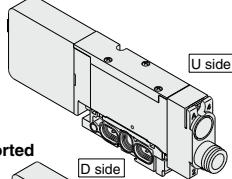

Top ported

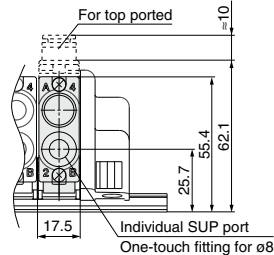
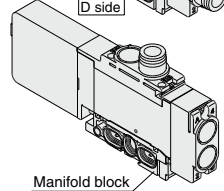

Description/Model	Stations				
	1	2	3	4	5
Valve	Single	●	●	●	
Option	Individual SUP spacer SSQ2000-P-4- <u>C8</u>				●
	SUP shut off position: Please specify.				●

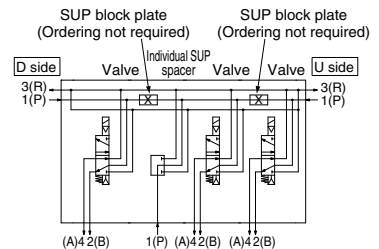

SQ2000 Series

Manifold Option Parts for SQ2000

Individual EXH spacer

SSQ2000-R-4-C8

Port size

Side ported	C8	One-touch fittings for ø8
ported	N9	One-touch fittings for ø5/16"
Top ported	L8	One-touch fittings for ø8
ported	LN9	One-touch fittings for ø5/16"

This is used to exhaust an individual valve when the exhaust from a valve interferes with other stations in the circuit (used for one station). Both sides of the station which is to be individually exhausted are shut off. (Refer to application example.)

* Specify the spacer mounting position and EXH passage shut off positions on the manifold specification sheet. Up to two shut off positions can be specified per unit.

(Four pieces of EXH block plate that shut off the exhaust are included with the individual EXH spacer, therefore, it is not necessary to order them separately.)

* No electrical wiring is connected to the manifold station with the individual EXH spacer.

When the wiring needs to be connected to the stations with the individual EXH spacer mounted, specify it on the manifold specification sheet.

* By changing the fitting shown in the drawing and the block plates, the spacer's specification can be changed later (from the individual EXH spacer to the individual SUP spacer).

* The number of spacers is not limited when ordered with the manifold. However, when adding individual for F, P, and J kits, it is limited to two units, one between manifold stations and another on the U side, due to the length of the lead wire.

* Model no. with manifold block:
SSQ2000-R-4-C8-M
L8

Side ported

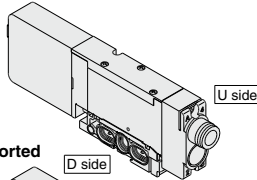

Top ported

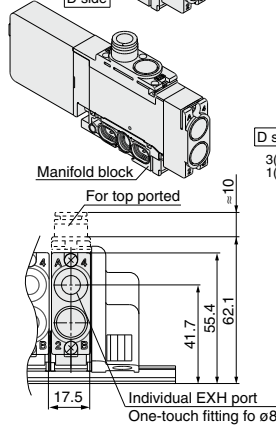

Description/Model	Stations				
	1	2	3	4	5
Valve	Single	●	●	●	●
Option	Individual EXH spacer SSQ2000-R-4-C8				
Option	EXH shut off position: Please specify.				

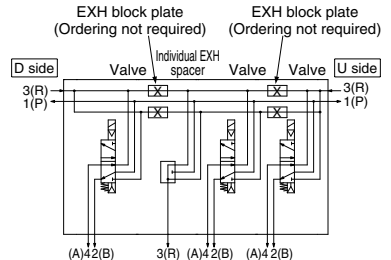

Individual SUP/EXH spacer

SSQ2000-PR1-4-C8

Port size

Side ported	C8	One-touch fittings for ø8
ported	N9	One-touch fittings for ø5/16"
Top ported	L8	One-touch fittings for ø8
ported	LN9	One-touch fittings for ø5/16"

This has both functions of the individual SUP and EXH spacers above. (Refer to application example.)

* Specify the spacer mounting position and SUP and EXH passage shut off positions on the manifold specification sheet. Up to two shut off positions each for SUP and EXH can be specified per unit. [Block plates that shut off the SUP and EXH passages are included with the individual SUP/EXH spacer, therefore, it is not necessary to order them separately (2 pcs. of SUP block plate and 4 pcs. of EXH block plate).]

* No electrical wiring is connected to the manifold station with the individual SUP/EXH spacer.

When the wiring needs to be connected to the stations with the individual SUP/EXH spacer mounted, specify it on the manifold specification sheet.

* By changing the fitting shown in the drawing and the block plates, the spacer's specification can be changed later.

* The number of spacers is not limited when ordered with the manifold. However, when adding individual for F, P, and J kits, it is limited to two units, one between manifold stations and another on the U side, due to the length of the lead wire.

* Model no. with manifold block:
SSQ2000-PR1-4-C8-M
L8

* Do not install any back pressure check valve on the manifold station, on which the spacer is to be mounted.

When installing the back pressure check valve on other manifold station, be sure to specify the manifold station position on the manifold specification sheet instead of ordering by specifying the manifold option symbol "B".

Side ported

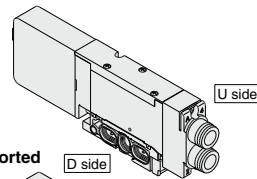

Top ported

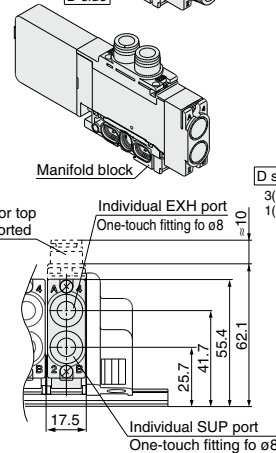

Description/Model	Stations				
	1	2	3	4	5
Valve	Single	●	●	●	●
Option	Individual SUP/EXH spacer SSQ2000-PR1-4-C8				
Option	SUP shut off position: Please specify.				
Option	EXH shut off position: Please specify.				

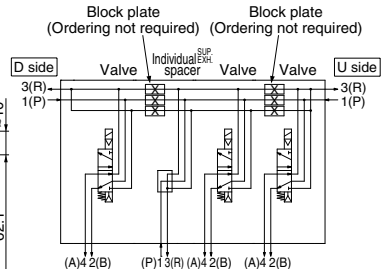

SUP block plate

SSQ1000-B-R

When supplying two different pressures, high and low, to one manifold, this is used between stations with different pressures. Also, it is used with an individual SUP spacer to shut off the air supply.

* Specify the station position on the manifold specification sheet.

<Block indication label>

When using block plates for SUP passage, indication label for confirmation of the blocking position from outside is attached. (One label of each)

* When ordering a block plate for SUP incorporated with the manifold, a block indication label is attached to the manifold.

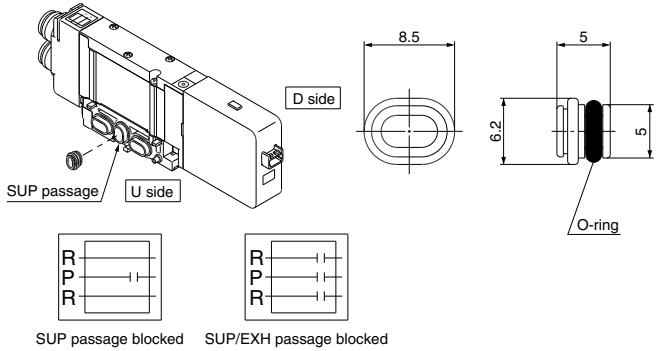

EXH block plate

SSQ2000-B-R

When the exhaust from a valve interferes with other stations in the circuit, this is used between stations to separate exhausts. Also, it is used with an individual EXH spacer to shut off the exhaust of individual valves.

* Specify the station position on the manifold specification sheet.

* Be sure to discharge the exhaust inside the EXH passage from the R port of the SUP/EXH block, etc. so that the exhaust pressure is not sealed.

<Block indication label>

When using block plates for EXH passage, indication label for confirmation of the blocking position from outside is attached. (One label of each)

* When ordering a block plate for EXH incorporated with the manifold, a block indication label is attached to the manifold.

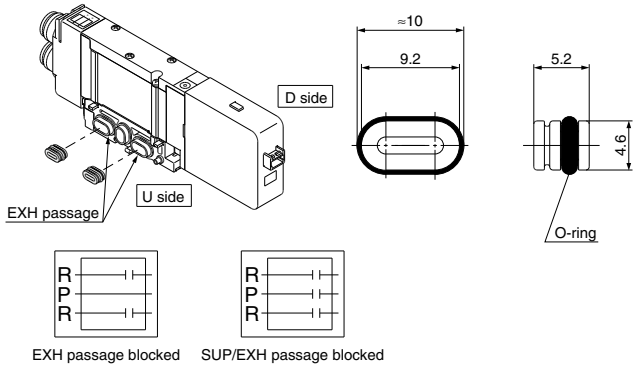

Back pressure check valve [-B]

SSQ2000-BP

It prevents cylinder malfunction caused by other valve exhaust. Insert it into R (EXH) port on the manifold side of a valve which is affected. It is effective when a single action cylinder is used or an exhaust center type solenoid valve is used.

* When a check valve for back pressure prevention is desired, and is to be installed only in certain manifold stations, clearly write the part number and specify the number of stations on the manifold specification sheet.

* When ordering this option incorporated with a manifold, suffix "-B" to the end of the manifold part number.

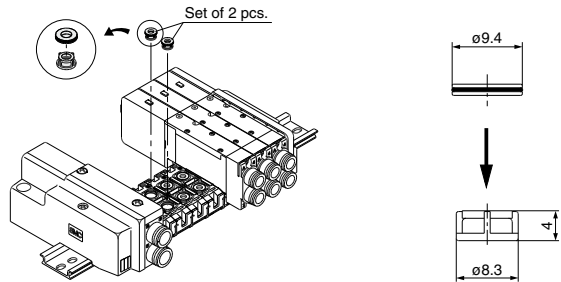

⚠ Caution

1. The back pressure check valve assembly is assembly parts with a check valve structure. However, as slight air leakage is allowed for the back pressure, take care the exhaust air will not be restricted at the exhaust port.
2. When a back pressure check valve is mounted, the effective area of the valve will decrease by about 20%.

SQ2000 Series

Manifold Option Parts for SQ2000

Name plate [-N]

SSQ2000-N3-Stations (1 to maximum)

It is a transparent resin plate for placing a label that indicates solenoid valve function, etc.

Insert it into the groove on the side of the end plate and bend it as shown in the figure. Also, the plate is difficult to bend for manifolds with only a few stations, therefore, remove the silencer cover to install it.

* When ordering this option incorporated with a manifold, suffix "-N" to the end of the manifold part number.

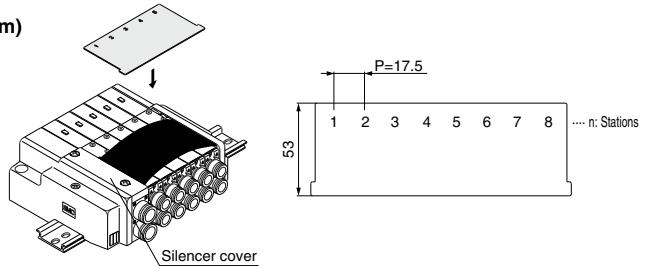

Blanking plug (For One-touch fitting)

04
KQ2P-06
08
10

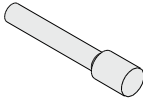

It is inserted into an unused cylinder port and SUP/EXH ports.

Purchasing order is available in units of 10 pieces.

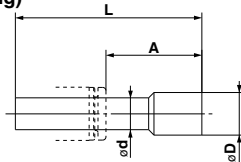

Dimensions

Applicable fittings size ød	Model	A	L	D
4	KQ2P-04	16	32	6
6	KQ2P-06	18	35	8
8	KQ2P-08	20.5	39	10
10	KQ2P-10	22	43	12

Port plug

VVQZ2000-CP

The plug is used to block the cylinder port when using a 5-port valve as a 3-port valve.

* Add "A" or "B" at the end of the valve part number when ordering with valves.

Example) SQ2141-5L1-C8-A (N.O. specifications)

↓
4(A) port plug

Example) SQ2141-5L1-C8-B (N.C. specifications)

↓
2(B) port plug

Example) SQ2141-5L1-C8-B-M

(B port plug with manifold block)

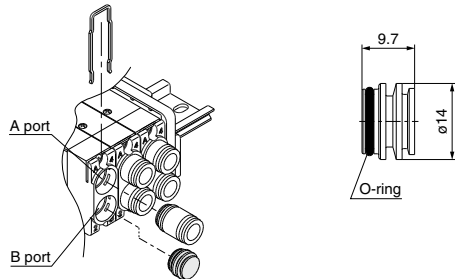

Direct EXH outlet, built-in silencer [-S]

This is a type with an exhaust port atop the manifold end plate. The built-in silencer exhibits an excellent noise suppression effect. (Noise reduction: 30 dB)

Note) A large quantity of drainage generated in the air source results in exhaust of air together with drainage.

* When ordering this option incorporated with a manifold, suffix "-S" to the end of the manifold part number.

* For precautions on handling and how to replace elements, refer to page 711.

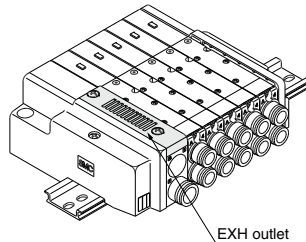

External pilot specifications [-R]

This can be used when the air pressure is 0.1 to 0.2 MPa lower than the minimum operating pressure of the solenoid valves or used for vacuum specifications.
 Add "R" to the part numbers of manifolds and valves to indicate the external pilot specifications.
 Add "R" to the part numbers of manifolds and valves to indicate the external pilot specifications.
 An M5 port will be installed on the top side of the manifold's SUP/EXH block.

- How to order valves (Example)
 SQ2140 **R** -5L1-C6
 ↓ External pilot specifications
- How to order manifold (Example)
 * Indicate "R" for an option.
 SS5Q24-08FD1-D**R**
 ↓ External pilot specifications

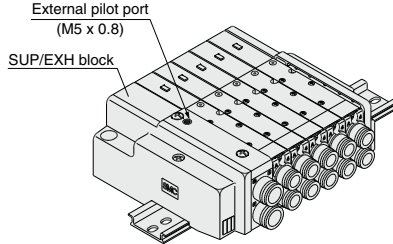

Note 1) Not applicable for dual 3 port valves.
 Note 2) Valves with the external pilot specifications have a pilot EXH with individual exhaust specifications and EXH can be pressurized. However, the pressure supplied from EXH should be 0.4 MPa or lower.

Dual flow fitting

SSQ2000-52A-**C10**

● Port size	
C10	ø10
N11	ø3/8"

To drive a large bore cylinder, two valve stations are operated simultaneously to double the air flow. This fitting is used on the cylinder ports in this situation. Available sizes are ø10 and ø3/8" One-touch fittings.
 * When ordering with valves, specify the valve part number without One-touch fitting and list the dual flow fitting part number.

Example) Valve part number (without Onetouch fitting)
 SQ2141-5L1-**C10**..... 2 sets
 * SSQ2000-52A-**C10**..... 1 set
 N11

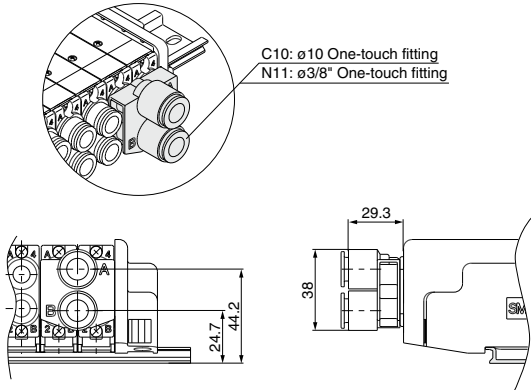

Silencer (For EXH port)

This is inserted into the centralized type EXH port (One-touch fitting).

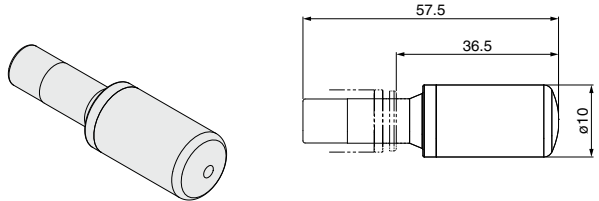

Specifications

Series	Model	Effective area (mm ²) (Cv factor)	Noise reduction (dB)
SQ2000	AN20-C10	30 (1.6)	30

SQ1000/2000 Series

Manifold Option for SQ1000/2000

Special Wiring Specifications

In the internal wiring of F kit and P kit, double wiring (connected to SOL. A and SOL. B) is adopted for each station regardless of the valve and option types. Mixed wiring of single and double wiring can be specified for the wiring specification.

1. How to order

Indicate option symbol "-K" in the manifold part number and be sure to specify station positions for single or double wiring on the manifold specification sheet.

Example) **SS5Q14 - 09 FD0 DKS**

↓ Others, option symbols: to be indicated alphabetically.

2. Wiring specifications

Connector terminal numbers are connected from solenoid station 1 on the A side in the order indicated by the arrows without skipping any terminal numbers.

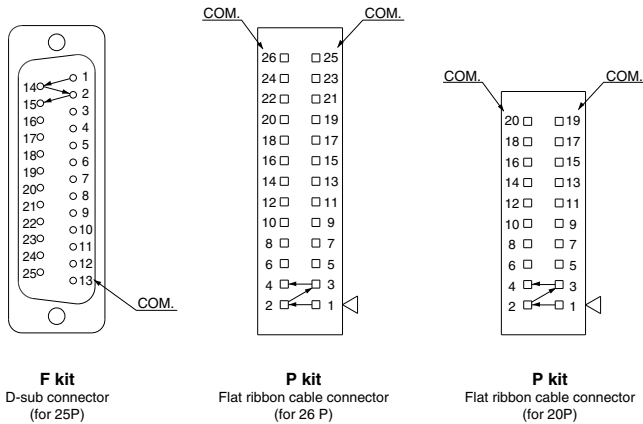

3. Maximum stations

The maximum number of manifold stations is determined by the number of solenoids. Count one point for a single solenoid type and two points for a double solenoid type. Determine the number of stations so that the total number of solenoids is no more than the maximum points in the table below.

Kit	F kit (D-sub connector)		P kit (Flat ribbon cable connector)	
	Type	FD□ 25P	PD□ 26P	PDC 20P
Max. points		24 points	24 points	18 points

Note) Maximum stations SQ1000: 24 stations
SQ2000: 16 stations

Special DIN Rail Length (DIN Rail Mounting (-D) Only)

The standard DIN rail provided is approximately 30 mm longer than the overall length of the manifold with a specified number of stations. The following options are also available.

● DIN rail length longer than the standard type (for stations to be added later, etc.)

In the manifold part number, specify "-D" for the manifold mounting symbol and add the number of required stations after the symbol.

Example) **SS5Q14-08FD0-D09BNK**



● Ordering DIN rail only

DIN rail part number

AXT100-DR-n

Note) For "n", enter a number from the "No." line in the table below.
For L dimension, refer to the dimensions of each kit.

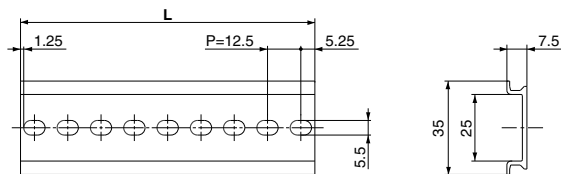

L Dimension

$$L = 12.5 \times n + 10.5$$

No.	1	2	3	4	5	6	7	8	9	10
L dimension	23	35.5	48	60.5	73	85.5	98	110.5	123	135.5
No.	11	12	13	14	15	16	17	18	19	20
L dimension	148	160.5	173	185.5	198	210.5	223	235.5	248	260.5
No.	21	22	23	24	25	26	27	28	29	30
L dimension	273	285.5	298	310.5	323	335.5	348	360.5	373	385.5
No.	31	32	33	34	35	36	37	38	39	40
L dimension	398	410.5	423	435.5	448	460.5	473	485.5	498	510.5

Direct Mounting Type (-E) (SQ2000 C Kit Only)

Manifold is mounted by using mounting holes of both sides of the manifold.

DIN rail is not sticking out of the edge of end plate.

Furthermore, the reinforcing part that comes to the bottom of the DIN rail is attached to the end plate assembly.

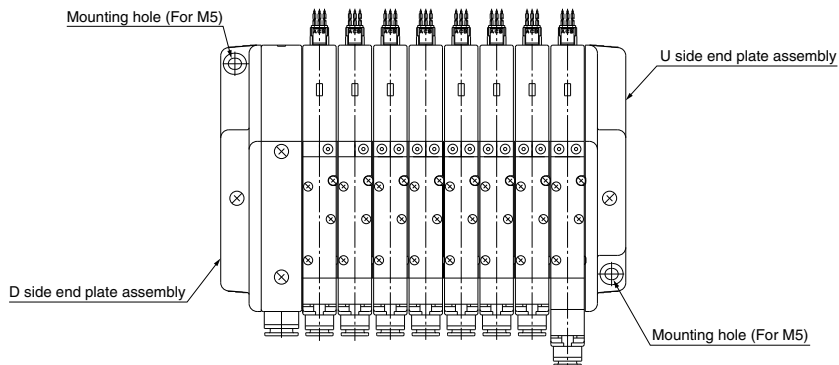

SQ1000/2000 Series

Manifold Option for SQ1000/2000

Negative Common Specifications

The following valve part numbers are for negative common specifications. Manifold part numbers are the same as standard.

● How to order negative common valves (Example)

SQ1140 N -5L1-C6

↓ Negative common specifications

Inch-size One-touch Fittings

For One-touch fittings in inch sizes, use the following part numbers. Also, the color of the release button is orange.

● How to order valves (Example)

SQ1140-5L1-□ N7

Port location	
Nil	Side ported
L	Top ported

↓ Cylinder port

Symbol	N1	N3	N7	N9
Applicable tubing O.D. (Inch)	ø1/8"	ø5/32"	ø1/4"	ø5/16"
4(A), 2(B) port	●	●	●	—
	—	●	●	●

● How to order manifold (Example)

Add "00T" at the end of the part number.

SS5Q14-08FD0-DN-00T

↓ 1 (P), 3 (R) port in inch size
 { SQ1000: ø5/16" (N9)
 { SQ2000: ø3/8" (N11)

How to Increase Manifold Stations for SQ1000/2000

1. How to Increase Manifold Stations

What to order

- Valves with manifold block (refer to pages 665 and 677) or the manifold blocks shown below. For F kit, P kit, and J kit, also order the lead wire assemblies in the next section.

Manifold Block Part No.

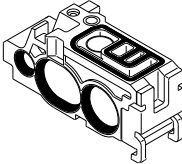
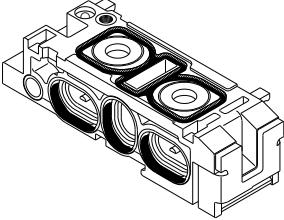
SQ1000	SQ2000												
													
<p>SSQ1000-1A-4-□</p> <p>Option ●</p> <table border="1"> <tbody> <tr> <td>Nil</td> <td>None</td> </tr> <tr> <td>B</td> <td>Back pressure check valve</td> </tr> <tr> <td>R</td> <td>External pilot specifications</td> </tr> </tbody> </table> <p>Note) Enter "-BR" for both options.</p>	Nil	None	B	Back pressure check valve	R	External pilot specifications	<p>SSQ2000-1A-4-□</p> <p>Option ●</p> <table border="1"> <tbody> <tr> <td>Nil</td> <td>None</td> </tr> <tr> <td>B</td> <td>Back pressure check valve</td> </tr> <tr> <td>R</td> <td>External pilot specifications</td> </tr> </tbody> </table> <p>Note) Enter "-BR" for both options.</p>	Nil	None	B	Back pressure check valve	R	External pilot specifications
Nil	None												
B	Back pressure check valve												
R	External pilot specifications												
Nil	None												
B	Back pressure check valve												
R	External pilot specifications												

How to Increase Manifold Stations for SQ1000/2000

For F kit, P kit

What to order: Lead wire assembly

SQ1000

D-sub connector kit (F kit)

● For single wiring **SSQ1000-40A-F-205**

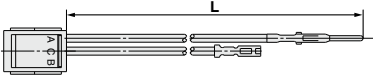

● For double wiring **SSQ1000-41A-F-280**

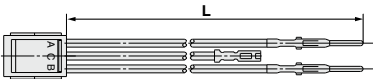

Stations	Symbol (L dimension)	Stations	Symbol (L dimension)
Station 2	165	Station 14	320
Station 3	175	Station 15	335
Station 4	190	Station 16	350
Station 5	205	Station 17	365
Station 6	215	Station 18	375
Station 7	230	Station 19	385
Station 8	245	Station 20	400
Station 9	260	Station 21	405
Station 10	280	Station 22	420
Station 11	290	Station 23	435
Station 12	300	Station 24	450
Station 13	310		

Flat ribbon cable kit (P kit)

● For single wiring **SSQ1000-40A-P-200**

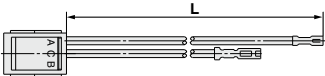

● For double wiring **SSQ1000-41A-P-275**

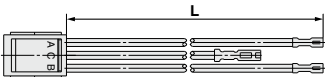

Stations	Symbol (L dimension)	Stations	Symbol (L dimension)
Station 2	160	Station 14	315
Station 3	170	Station 15	330
Station 4	185	Station 16	345
Station 5	200	Station 17	360
Station 6	210	Station 18	370
Station 7	225	Station 19	380
Station 8	240	Station 20	395
Station 9	255	Station 21	400
Station 10	275	Station 22	415
Station 11	285	Station 23	430
Station 12	295	Station 24	445
Station 13	305		

SQ2000

D-sub connector kit (F kit)

● For single wiring **SSQ1000-40A-F-250**

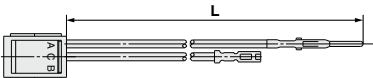

● For double wiring **SSQ1000-41A-F-350**



Stations	Symbol (L dimension)	Stations	Symbol (L dimension)
Station 2	190	Station 14	430
Station 3	210	Station 15	450
Station 4	230	Station 16	470
Station 5	250	Station 17	490
Station 6	270	Station 18	510
Station 7	290	Station 19	530
Station 8	310	Station 20	550
Station 9	330	Station 21	570
Station 10	350	Station 22	590
Station 11	370	Station 23	610
Station 12	390	Station 24	630
Station 13	410		

Flat ribbon cable kit (P kit)

● For single wiring **SSQ1000-40A-P-250**

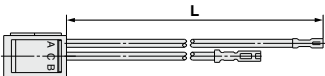

● For double wiring **SSQ1000-41A-P-350**

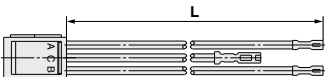

Stations	Symbol (L dimension)	Stations	Symbol (L dimension)
Station 2	190	Station 14	430
Station 3	210	Station 15	450
Station 4	230	Station 16	470
Station 5	250	Station 17	490
Station 6	270	Station 18	510
Station 7	290	Station 19	530
Station 8	310	Station 20	550
Station 9	330	Station 21	570
Station 10	350	Station 22	590
Station 11	370	Station 23	610
Station 12	390	Station 24	630
Station 13	410		

SQ1000/2000 Series

How to Increase Manifold Stations for SQ1000/2000

Steps for adding stations

- 1 Loosen the clamp screw on the U side end plate and open the manifold.
- 2 Mount the manifold block or valve with manifold block to be added.
- 3 Press on the end plate to eliminate any space between the manifold blocks and tighten the clamp screw.
(Proper tightening torque: 0.8 to 1.0 N·m)
- 4 In the case of F kit or P kit, remove the connector housing from the DIN rail and connect the wiring.

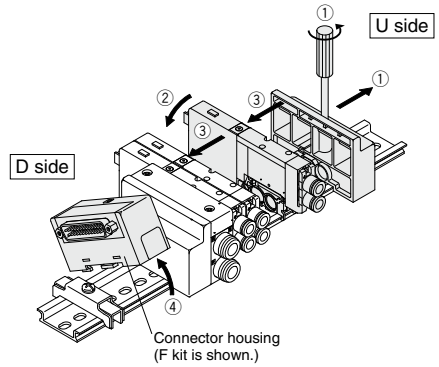

2. Connection Method

(1) Connecting common wire

Insert the red lead wire (common wire) of the connector to be added into the adjacent connector as shown in the drawing below. After inserting, lightly pull on the wire to confirm that the socket is locked.

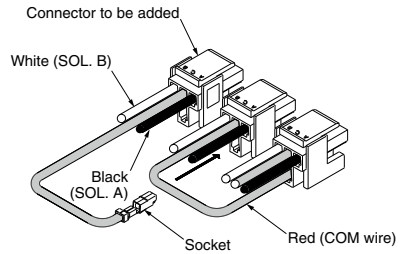

(2) Pulling out connector

Pull out the connector to connect the lead wires for SOL. A and SOL. B. Insert a flat head screwdriver into the slot of the housing cover and remove it. Remove the manual lever and pull out the connector.

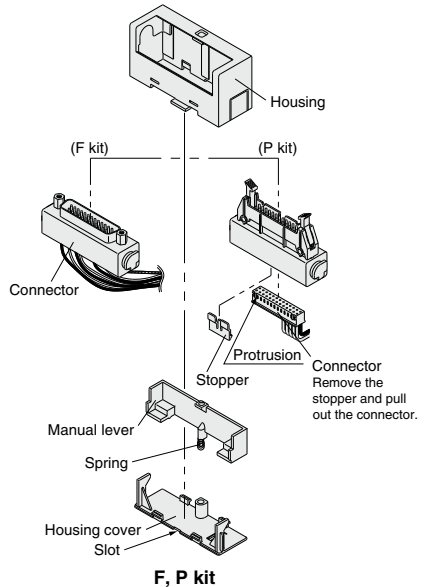

(3) Connector connection/Connect the black and white lead wire pins to the positions shown below in accordance with each kit.

- ⚠ Caution**
- After inserting the pin, confirm that the pin hook is locked by lightly pulling the lead wire.
 - Do not pull the lead wire forcefully when connecting. Also, take care that lead wires do not get caught between manifolds or when remounting the housing.

Wiring (F Kit: D-sub Connector Kit)

Procedure) Based on the manifold specifications, station 1 of SOL.A (black wire) will be terminal number 1 of the D-sub connector, and for station 2 and thereafter, connect black wires, then white wires in the order as shown below by the arrows.

Manifold Specifications' Example

Stations	1	2	3	4	5	6
Single wiring	○	○				
Double wiring			○	○	○	

* The drawing above shows connections based on the manifold specifications' example in the table to the left.

Wiring (P Kit: Flat Ribbon Cable Kit)

Procedure) Based on the manifold specifications, station 1 of SOL.A (black wire) will be terminal number 1B of the flat ribbon cable connector, and for station 2 and thereafter, connect black wires, then white wires in the order as shown below by the arrows.

Manifold Specifications' Example

Stations	1	2	3	4	5	6
Single wiring	○	○				○
Double wiring			○	○	○	

* The drawing above shows connections for type 26P flat ribbon wiring cable connector based on the manifold specifications' example in the table to the left. For type 20P, the connection will be the same as above except that COM changes to 10A and 10B.

SQ1000 Series

Construction: SQ1000 Series Plug Lead Type Main Parts and Pilot Valve Assembly

Metal seal type

Single: SQ1140

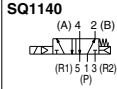
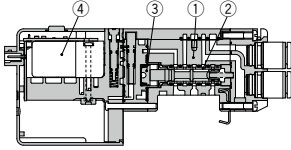

Double: SQ1240D

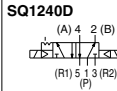
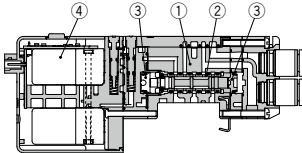

3 position: SQ1440^{3/5}

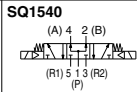
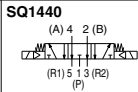
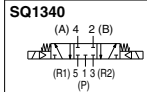
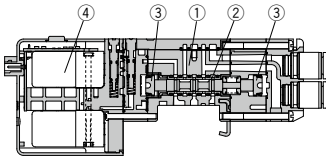

Component Parts

No.	Description	Material
1	Body	Zinc die-casted
2	Spool/Sleeve	Stainless steel (Metal seal)
3	Piston	Resin
4	Pilot valve assembly	—

Rubber seal type

Single: SQ1141

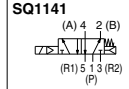
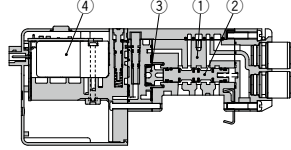

Double: SQ1241D

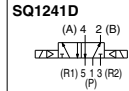
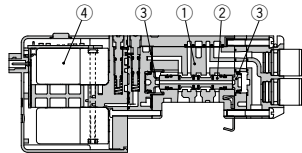

3 position: SQ1441^{3/5}

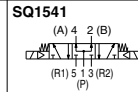
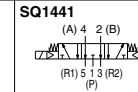
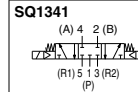
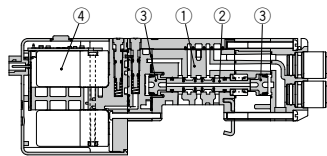

Dual 3 port valve: SQ1^A_B41^C

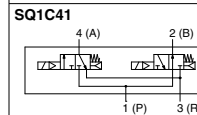
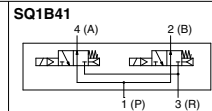
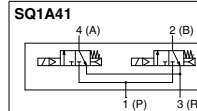
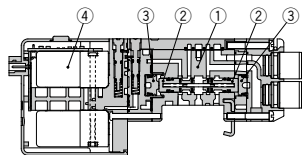

Construction: SQ2000 Series Plug Lead Type Main Parts and Pilot Valve Assembly

Metal seal type

Single: SQ2140

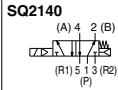
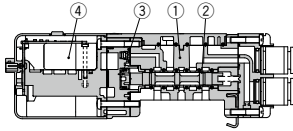

Double: SQ2240D

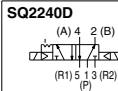
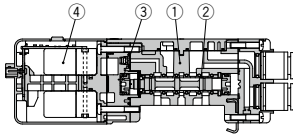

3 position: SQ2440^{3/5}

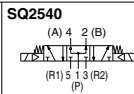
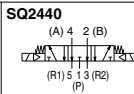
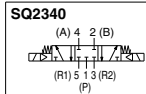
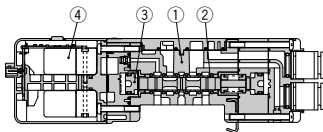

Rubber seal type

Single: SQ2141

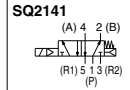
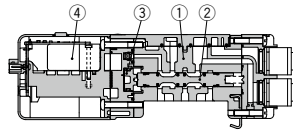

Double: SQ2241D

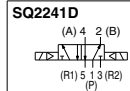
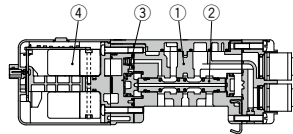

3 position: SQ2441^{3/5}

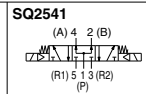
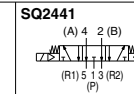
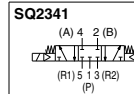
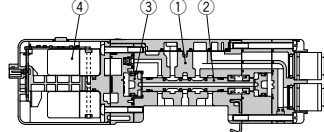

Component Parts

No.	Description	Material
1	Body	Aluminum die-casted
2	Spool/Sleeve	Stainless steel (Metal seal)
2	Spool	Aluminum (Rubber seal)
3	Piston	Resin
4	Pilot valve assembly	—

Dual 3 port valve: SQ2^A_B41^C

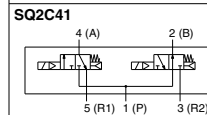
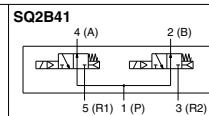
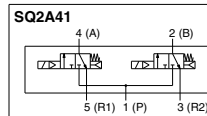
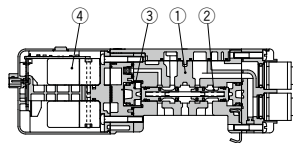

SQ1000 Series

Manifold Exploded View: SQ1000 (Plug Lead Type Manifold) SS5Q14

(F, P, C kit)

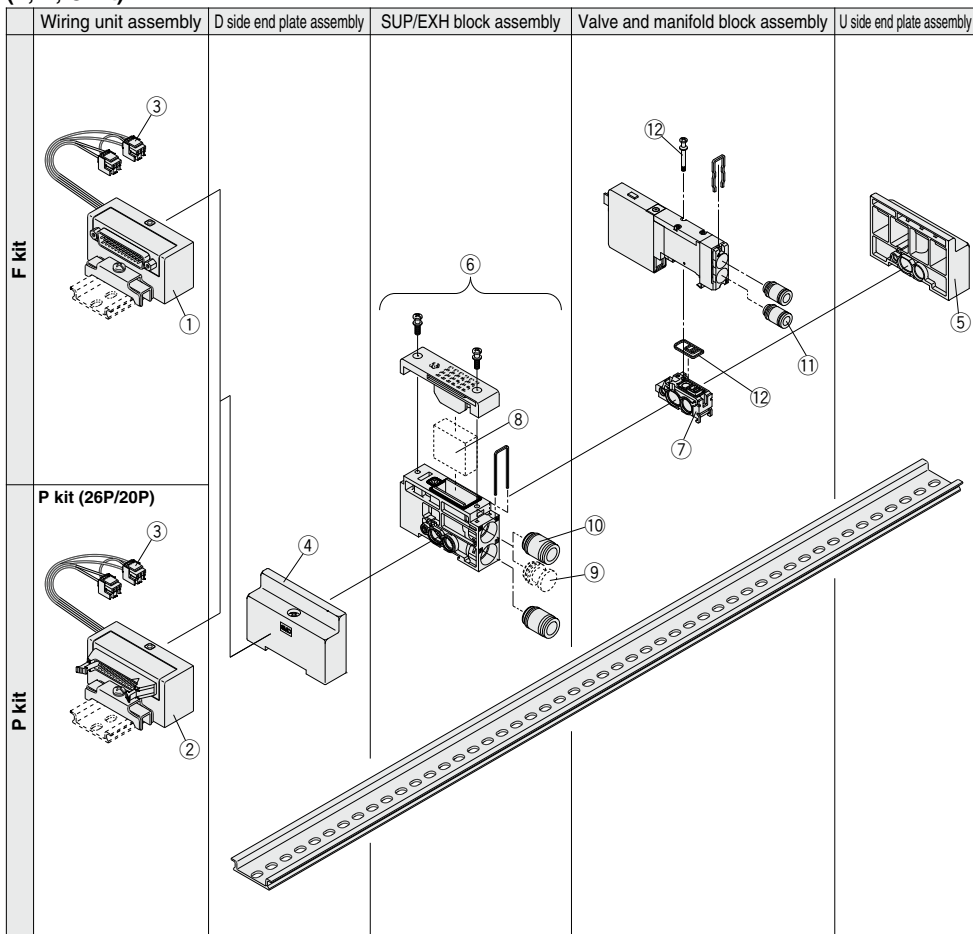

Manifold Spare Parts

Refer to pages 701 to 703 of "How to Increase Manifold Stations" regarding the mounting of each spare parts.

<① D-sub connector housing assembly>

AXT100-40-FL25-S **03**

Wiring		Stations	
S	Single wiring	01	For 1 station
D	Double wiring	⋮	⋮
		24	For 24 stations

<② Flat ribbon cable connector housing assembly>

AXT100-40-PL26-PL20-S **03**

Wiring		Stations (Note)	
S	Single wiring	01	For 1 station
D	Double wiring	⋮	⋮
		24	For 24 stations

Note) PL26: 01 to 24 (P kit, 26P)
PL20: 01 to 18 (P kit, 20P)

<③ Lead wire assembly>

(For F kit)

For station 1 **SSQ1000-4** **1** **B-F-155**

Wiring	
0	For single (2-wire)
1	For double (3-wire)

For station 2 to 24 **SSQ1000-4** **1** **A-F-205**

Wiring	
0	For single (2-wire)
1	For double (3-wire)

Lead wire length

Stations	L dimension (mm)	Stations	L dimension (mm)	Stations	L dimension (mm)	Stations	L dimension (mm)
Station 2	165	Station 8	245	Station 14	320	Station 20	400
Station 3	175	Station 9	260	Station 15	335	Station 21	405
Station 4	190	Station 10	280	Station 16	350	Station 22	420
Station 5	205	Station 11	290	Station 17	365	Station 23	435
Station 6	215	Station 12	300	Station 18	375	Station 24	450
Station 7	230	Station 13	310	Station 19	385		

(For P kit)

For station 1 **SSQ1000-4** **1** **B-P-150**

Wiring	
0	For single (2-wire)
1	For double (3-wire)

For station 2 to 24 **SSQ1000-4** **1** **A-P-200**

Wiring	
0	For single (2-wire)
1	For double (3-wire)

Lead wire length

Stations	L dimension (mm)	Stations	L dimension (mm)	Stations	L dimension (mm)	Stations	L dimension (mm)
Station 2	160	Station 8	240	Station 14	315	Station 20	395
Station 3	170	Station 9	255	Station 15	330	Station 21	400
Station 4	185	Station 10	275	Station 16	345	Station 22	415
Station 5	200	Station 11	285	Station 17	360	Station 23	430
Station 6	210	Station 12	295	Station 18	370	Station 24	445
Station 7	225	Station 13	305	Station 19	380		

(For C kit)

AXT661-1 **3** **AL-**

Wiring	
3	For double (3-wire)
4	For single (2-wire)

Symbol	L dimension (mm)
Nil	300
6	600
10	1000
15	1500
20	2000
25	2500
30	3000
50	5000

<④ D side end plate assembly>

SSQ1000-3A-4

<⑤ U side end plate assembly>

SSQ1000-2A-4

<⑥ SUP/EXH block assembly>

SSQ1000-PR-4-C8

Port size	
C6	One-touch fitting for ø6
C8	One-touch fitting for ø8
N7	One-touch fitting for ø1/4"
N9	One-touch fitting for ø5/16"

Option	
Nil	Common exhaust type
R	External pilot
S	Built-in silencer, direct exhaust

Note) Enter "-RS" for both options.

<⑦ Manifold block assembly>

SSQ1000-1A-4 Including gaskets ^⑫

Option	
Nil	None
B	Back pressure check valve
R	External pilot specifications

Note) Enter "-BR" for both options.

<⑧ Element>

SSQ1000-SE

Note) Part number for a 10 piece set of elements. Refer to page 711 for replacement procedures.

<⑨ Port plug>

VVQZ200-CP

<⑩ Fitting assembly>

(For P, R port)

VVQ1000-51A-C8

Port size	
C6	One-touch fitting for ø6
C8	One-touch fitting for ø8
N7	One-touch fitting for ø1/4"
N9	One-touch fitting for ø5/16"

Note) Purchasing order is available in units of 10 pieces.

<⑪ Fitting assembly>

(For cylinder port)

VVQ1000-50A-C6

Port size	
C3	One-touch fitting for ø3.2
C4	One-touch fitting for ø4
C6	One-touch fitting for ø6
M5	M5 thread
N1	One-touch fitting for ø1/8"
N3	One-touch fitting for ø5/32"
N7	One-touch fitting for ø1/4"

Note) Purchasing order is available in units of 10 pieces.

<⑫ Gasket and screw assembly>

SQ1000-GS

Note) Part number for 10 pieces each of gaskets and screws.

SQ2000 Series

Manifold Exploded View: SQ2000 (Plug Lead Type Manifold) SS5Q24

(F, P, C kit)

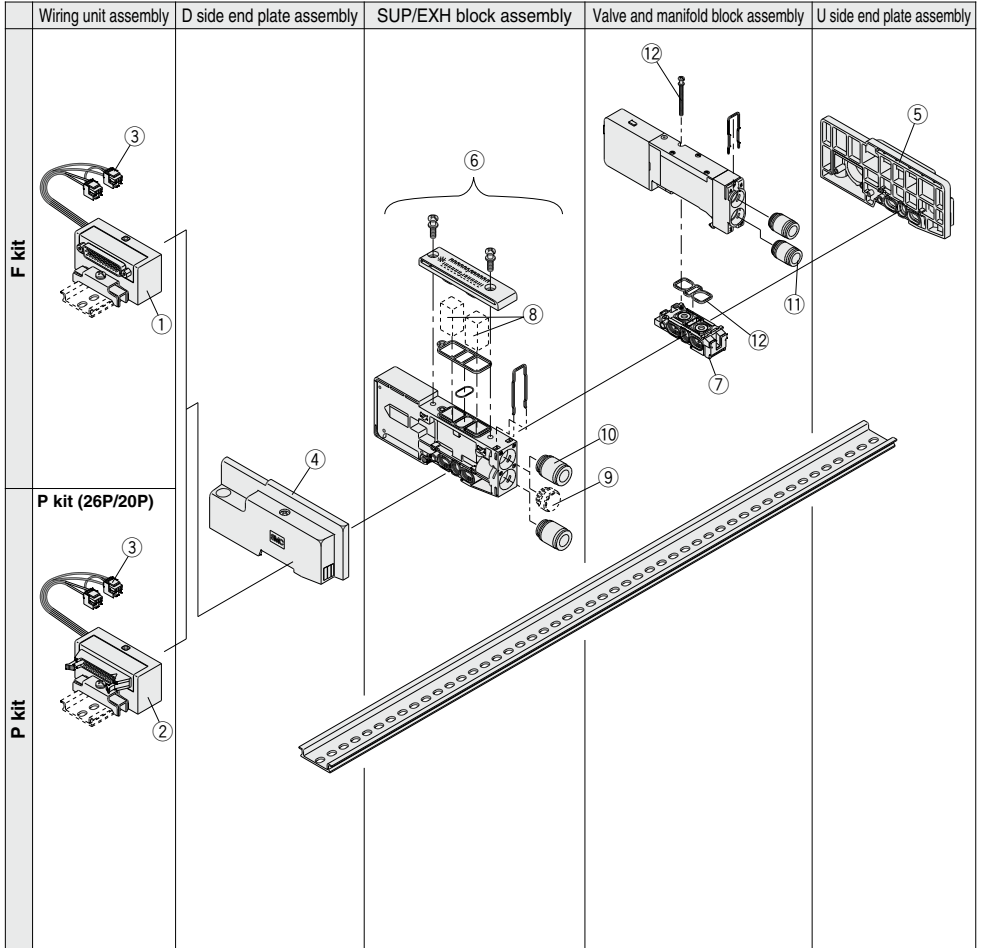

Manifold Spare Parts

Refer to pages 701 to 703 of "How to Increase Manifold Stations" regarding the mounting of each spare parts.

<① D-sub connector housing assembly>

AXT100 - 41 - FL25 - S 03

Wiring		Stations	
S	Single wiring	01	For 1 station
D	Double wiring	:	:
		12	For 12 stations

<② Flat ribbon cable connector housing assembly>

**AXT100 - 41 - PL26
PL20 - S 03**

Wiring		Stations (Note)		Note
S	Single wiring	01	For 1 station	PL26: 01 to 12 (P kit, 26P)
D	Double wiring	:	:	PL20: 01 to 09 (P kit, 20P)
		12	For 12 stations	

<③ Lead wire assembly>

(For F kit)

For station 1 **SSQ1000 - 4 1 B - F - 170**

Wiring	
0	For single (2-wire)
1	For double (3-wire)

For station 2 to 24 **SSQ1000 - 4 1 A - F - 230**

Wiring	
0	For single (2-wire)
1	For double (3-wire)

Lead wire length

Stations	L dimension (mm)	Stations	L dimension (mm)	Stations	L dimension (mm)	Stations	L dimension (mm)
Station 2	190	Station 8	310	Station 14	430	Station 20	550
Station 3	210	Station 9	330	Station 15	450	Station 21	570
Station 4	230	Station 10	350	Station 16	470	Station 22	590
Station 5	250	Station 11	370	Station 17	490	Station 23	610
Station 6	270	Station 12	390	Station 18	510	Station 24	630
Station 7	290	Station 13	410	Station 19	530		

(For P kit)

For station 1 **SSQ1000 - 4 1 B - P - 170**

Wiring	
0	For single (2-wire)
1	For double (3-wire)

For station 2 to 24 **SSQ1000 - 4 1 A - P - 310**

Wiring	
0	For single (2-wire)
1	For double (3-wire)

Lead wire length

Stations	L dimension (mm)	Stations	L dimension (mm)	Stations	L dimension (mm)	Stations	L dimension (mm)
Station 2	190	Station 8	310	Station 14	430	Station 20	550
Station 3	210	Station 9	330	Station 15	450	Station 21	570
Station 4	230	Station 10	350	Station 16	470	Station 22	590
Station 5	250	Station 11	370	Station 17	490	Station 23	610
Station 6	270	Station 12	390	Station 18	510	Station 24	630
Station 7	290	Station 13	410	Station 19	530		

(For C kit)

AXT661 - 1 3 AL - 6

Wiring		Lead wire length	
3	For double (3-wire)	Symbol	L dimension (mm)
4	For single (2-wire)	Nil	300

6	600
10	1000
15	1500
20	2000
25	2500
30	3000
50	5000

<④ D side end plate assembly>

SSQ2000 - 3A - 4

Manifold mounting	
Nil	DIN rail mounting type
E	Direct mounting type

<⑤ U side end plate assembly>

SSQ2000 - 2A - 4 - 1

Manifold mounting	
Nil	DIN rail mounting type
E	Direct mounting type

<⑥ SUP/EXH block assembly>

SSQ2000 - PR - 3 - C10

Port size		Option	
C8	One-touch fitting for ø8	Nil	Common exhaust type
C10	One-touch fitting for ø10	R	External pilot
N9	One-touch fitting for ø5/16"	S	Built-in silencer, direct exhaust
N11	One-touch fitting for ø3/8"		

Note) Enter "-RS" for both options.

<⑦ Manifold block assembly>

SSQ2000 - 1A - 4 -

Including gaskets ⑫

Option	
Nil	None
B	Back pressure check valve
R	External pilot specifications

Note) Enter "-BR" for both options.

<⑧ Element>

SSQ2000 - SE

Note) Part number for a 10 piece set of elements. Refer to page 711 for replacement procedure.

<⑨ Port plug>

VVQZ3000 - CP

<⑩ Fitting assembly>

(For P, R port)

VVQ2000 - 51A - C10

Port size	
C8	One-touch fitting for ø8
C10	One-touch fitting for ø10
N9	One-touch fitting for ø5/16"
N11	One-touch fitting for ø3/8"

Note) Purchasing order is available in units of 10 pieces.

<⑪ Fitting assembly>

(For cylinder port)

VVQ1000 - 51A - C8

Port size	
C4	One-touch fitting for ø4
C6	One-touch fitting for ø6
C8	One-touch fitting for ø8
N3	One-touch fitting for ø5/32"
N7	One-touch fitting for ø1/4"
N9	One-touch fitting for ø5/16"

Note) Purchasing order is available in units of 10 pieces.

<⑫ Gasket and screw assembly>

SQ2000 - GS

Note) Part number for 10 pieces each of gaskets and screws.



SQ1000/2000 Series Specific Product Precautions 1

Be sure to read this before handling the products.

Refer to page 8 for safety instructions and pages 9 to 15 for 3/4/5 port solenoid valve precautions.

Manual Override

⚠ Warning

Use to switch the main valve.

Push Type (Tool Required)

Push down on the manual override button with a small screwdriver until it stops.

SQ1000

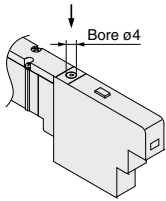

SQ2000

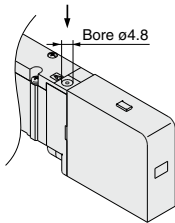

Locking Type (Tool Required)

Push down completely on the manual override button with a small screwdriver. While down, turn clockwise 90° to lock it. Turn it counterclockwise to release it.

SQ1000

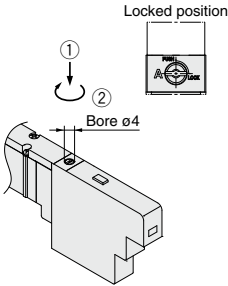

SQ2000

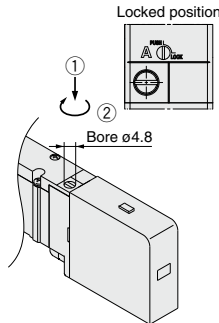

Slide Locking Type (Manual Type) (SQ2000 only)

The manual override is locked by sliding it all the way to the pilot valve side (ON side) with a small flat head screwdriver or finger. Slide it to the fitting side (OFF side) to release it. In addition, it can also be used as a push type by using a screwdriver, etc., of $\phi 2$ or less.

SQ2000

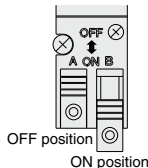
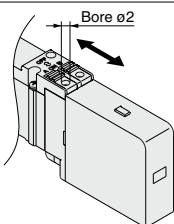

Light/Surge Voltage Suppressor

⚠ Caution

Indicator lights are all positioned on one side for both single solenoid and double solenoid types.

For double, 3 position, and 4 position dual 3 port types, 2 colors are used to indicate the energization of A side or B side.

SQ1000

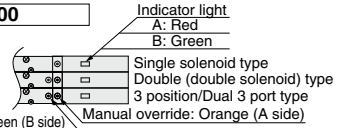

SQ2000

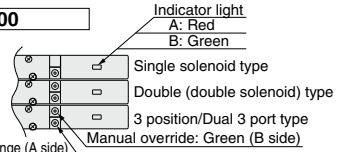

● Single Solenoid Type (SQ1000/2000)

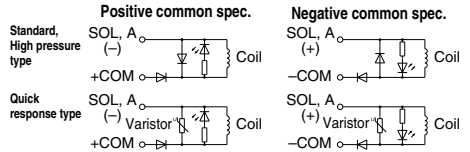

(Note) With quick response type, approximately -40 V of coil surge voltage is generated when the valve is switched OFF.

● Double Type (SQ1000/2000)

● 3 Position Type (SQ1000/2000)

● 4 Position Dual 3 Port Type (SQ1000/2000)

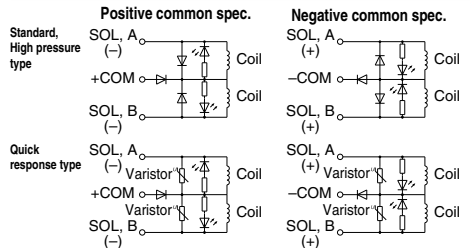

(Note) With quick response type, approximately -40 V of coil surge voltage is generated when the valve is switched OFF.

Continuous Duty

⚠ Caution

If a valve is energized continuously for a long period of time, the rise in temperature due to heat-up of the coil assembly may cause a decline in solenoid valve performance, reduce service life, or have adverse effects on peripheral equipment. When the valve is continuously energized, use the standard type (0.4 W) at ambient temperature of 40°C or less with proper heat radiation. In particular, if three or more adjacent stations on the manifold are energized simultaneously for extended periods of time or if the valves on A side and B side of the dual 3 port valve are energized simultaneously for a long period of time, take special care as the temperature rise will be greater.



SQ1000/2000 Series Specific Product Precautions 2

Be sure to read this before handling the products.

Refer to page 8 for safety instructions and pages 9 to 15 for 3/4/5 port solenoid valve precautions.

Mounting and Removal of Valves

⚠ Caution

Mounting

- Insert the hook of the valve into the bracket on the manifold block, then push the valve down into place and tighten the mounting screw.
- Tighten the screw with the appropriate tightening torque shown below.

SQ1000	0.17 to 0.23 N·m
SQ2000	0.25 to 0.35 N·m

- When pushing the valve down, press it on the area near the manual override. Be careful not to push the solenoid cover.

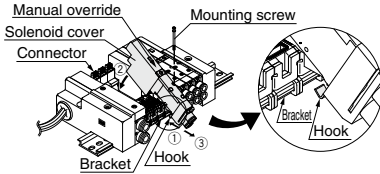

Removing

- Loosen the valve mounting screw, lift the valve from the solenoid cover side and remove it by sliding it in the direction of arrow ③.

If it is difficult to loosen the screw, loosen it while pressing the valve gently on the area near the manual override.

Mounting and Removal of Manifold with DIN Rail

⚠ Caution

Removing Manifold from DIN Rail

- ① Loosen the end plate clamping screws on both sides until they turn freely. (The screws do not come out.)
- ② Remove the manifold from the DIN rail by lifting it from the solenoid cover side.

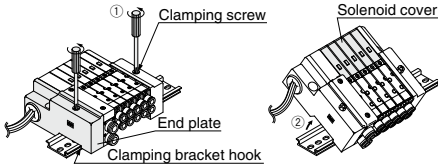

When a manifold contains a large number of stations and it is difficult to remove all at once, separate the manifold into several sections before removing it.

Mounting Manifold on DIN Rail

The procedure is the reverse of that above. After tightening the clamping screw on one side, push on the opposite end plate so that there are no gaps between the manifold blocks and then tighten the other clamping screw.

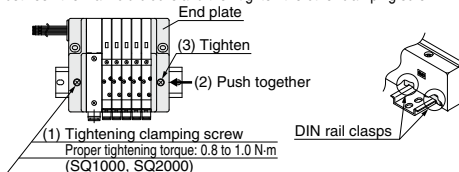

Confirm that the DIN rail clasps are securely hooked into the DIN rail.

Replacement of Cylinder Port Fittings

⚠ Caution

The cylinder port fittings are a cassette for easy replacement. Fittings are secured with a clip that is inserted from the top side of the valve. Remove the clip with a flat head screwdriver, etc., to replace the fittings.

To mount a fitting, insert the fitting assembly until it stops and reinsert the clip to its designated position.

Applicable tubing O.D. (mm)	Fitting assembly part no.	
	SQ1000	SQ2000
3.2	VVQ1000-50A-C3	—
4	VVQ1000-50A-C4	VVQ1000-51A-C4
6	VVQ1000-50A-C6	VVQ1000-51A-C6
8	—	VVQ1000-51A-C8

* Part numbers above are for one fitting; however, order them in 10 piece units.

⚠ Caution

Use caution that O-rings must be free from scratches and dust. Otherwise, air leakage may result.

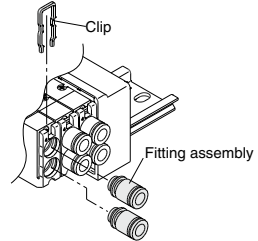

Built-in Silencer Replacement Element

⚠ Caution

A filter element is built into the manifold base end plate. When the element becomes dirty and clogged, this will cause trouble such as a drop in the cylinder speed, etc. Therefore, replace the element regularly.

Element part no.

Type	Element part no.	
	SQ1000	SQ2000
Built-in silencer direct exhaust (-S)	SSQ1000-SE	SSQ2000-SE

* Part numbers above are for a set of ten elements.

To replace an element, remove the cover on the top side of the end plate and remove the old element with a flat head screwdriver, etc.

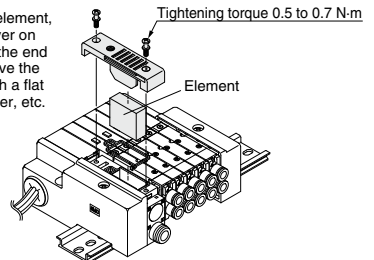

How to Calculate the Flow Rate

For obtaining the flow rate, refer to the [Web Catalog](#).

■ Trademark

DeviceNet® is a registered trademark of ODVA, Inc.