

Sponge Pad

Symbol/Form

S: Sponge

Pad diameter $\varnothing 4, \varnothing 6, \varnothing 8, \varnothing 10, \varnothing 15$

■ For the adsorption of workpieces with bumps

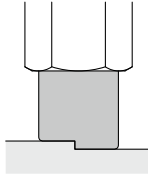

Mounting Bracket Part Nos.

Adapter Assembly p. 293

How to Order

Pad unit ZP2- S GC

* Pad unit's sales unit: 10 pcs.



1 Pad O.D.

Symbol	Pad O.D.
04	$\varnothing 4$
06	$\varnothing 6$
08	$\varnothing 8$
10	$\varnothing 10$
15	$\varnothing 15$

2 Double-sided tape

Symbol	Double-sided tape
Nil	None
D	With double-sided tape

3 Pad material

Symbol	Material
GC	Conductive CR sponge

Dimensions: Pad Unit

ZP2-04S GC

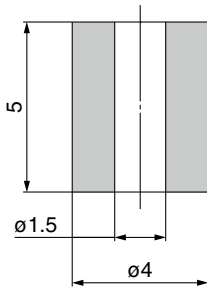

ZP2-06S GC

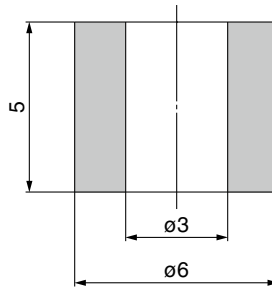

ZP2-08S GC

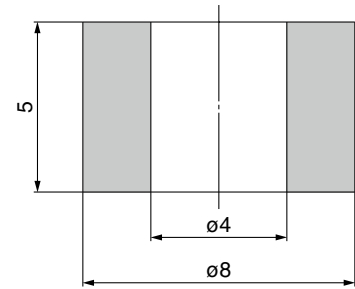

ZP2-10S GC

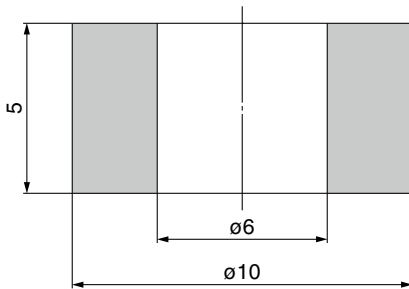

ZP2-15S GC

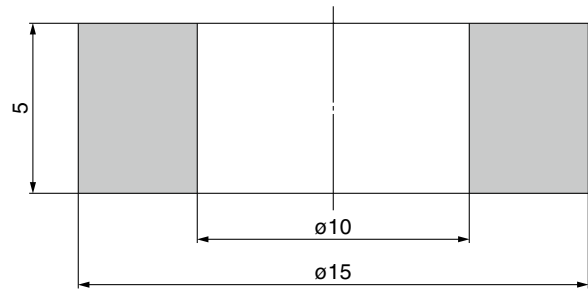

Adapter Mounting Dimensions

If an adapter will be made by the customer, design the adapter with the dimensions shown below.

Applicable pad 04S

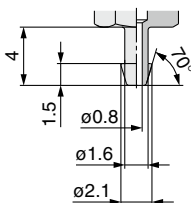

Applicable pad 06S

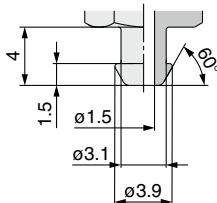

Applicable pad 08S

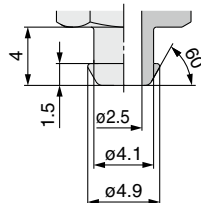

Applicable pad 10S

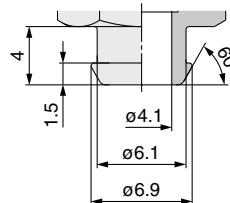

Applicable pad 15S

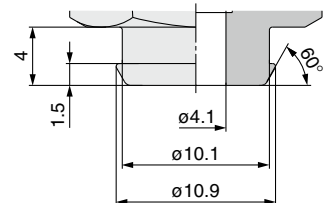

Model Selection

For Special Applications

Mark-free

For Film Adsorption

Multistage

Flat

Nozzle

Sponge

For Disk Adsorption

For Panel Holding

Ball Spine Buffer

Construction

Mounting Bracket Assembly

Precautions

Sponge Pad **ZP2 Series**

How to Order

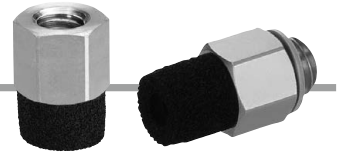

With adapter **ZP2 - T** **S** **GC -**

1
2
3
4
5

•Sponge

1 Vacuum inlet direction

Symbol	Direction
T	Vertical

2 Pad O.D.

Symbol	Pad O.D.
04	ø4
06	ø6
08	ø8
10	ø10
15	ø15

3 Double-sided tape

Symbol	Double-sided tape
Nil	None
D	With double-sided tape

4 Pad material

Symbol	Material
GC	Conductive CR sponge

5 Connection thread

Symbol	Thread size	Applicable pad O.D. symbol				
		ø04	ø06	ø08	ø10	ø15
A3	M3 x 0.5 (Male thread)	●	—	—	—	—
A5	M5 x 0.8 (Male thread)	—	●	●	●	●
B3	M3 x 0.5 (Female thread)	●	—	—	—	—
B5	M5 x 0.8 (Female thread)	—	●	●	●	●

Dimensions: With Adapter

ZP2-T04SGC-A3

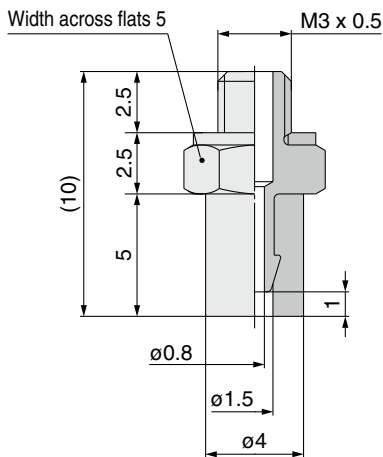

ZP2-T06SGC-A5

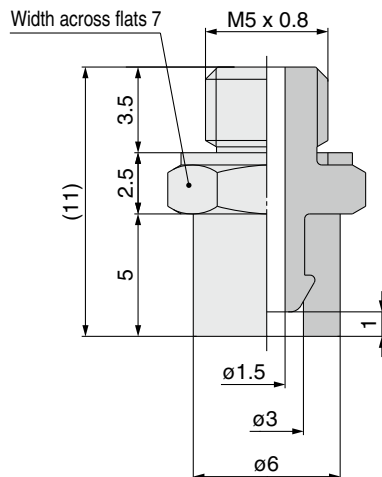

ZP2-T08SGC-A5

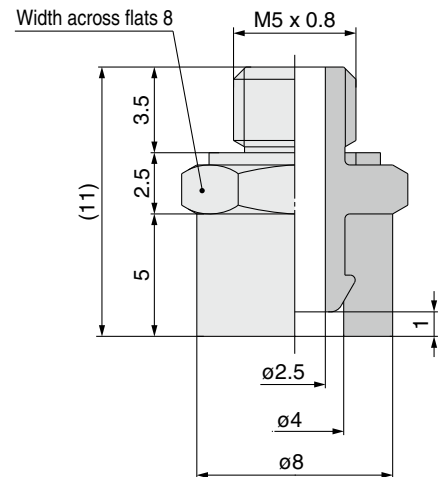

Dimensions: With Adapter

ZP2-T10S □ GC-A5

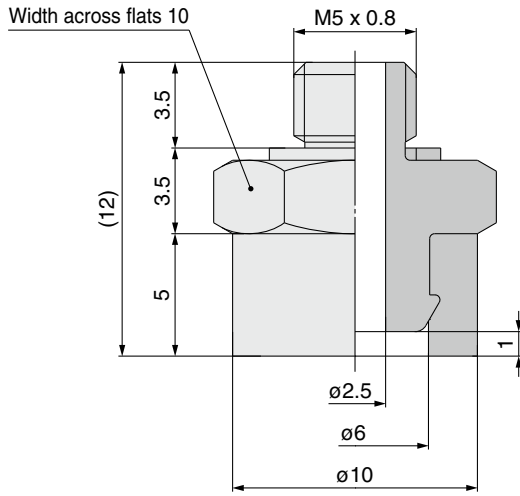

ZP2-T15S □ GC-A5

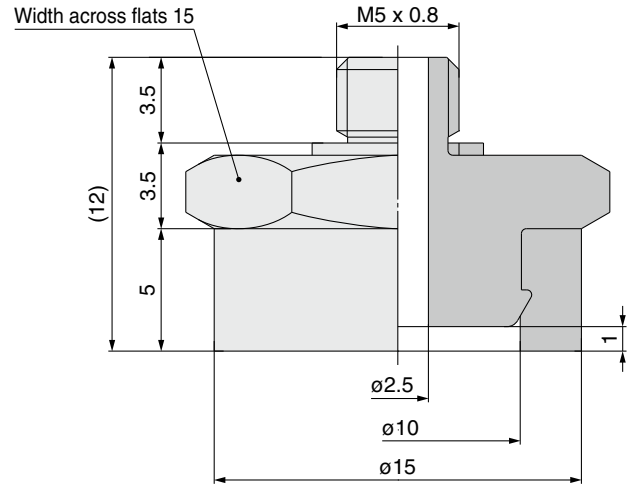

ZP2-T04S □ GC-B3

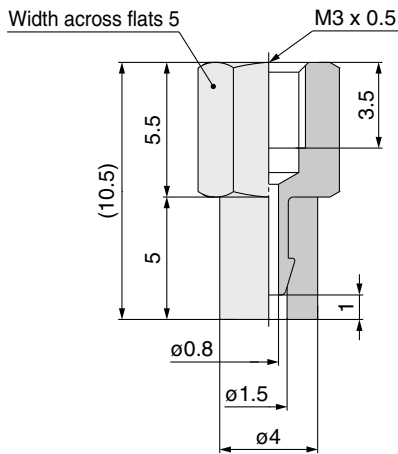

ZP2-T06S □ GC-B5

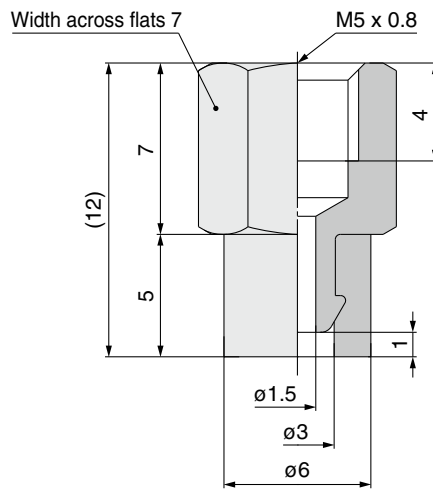

ZP2-T08S □ GC-B5

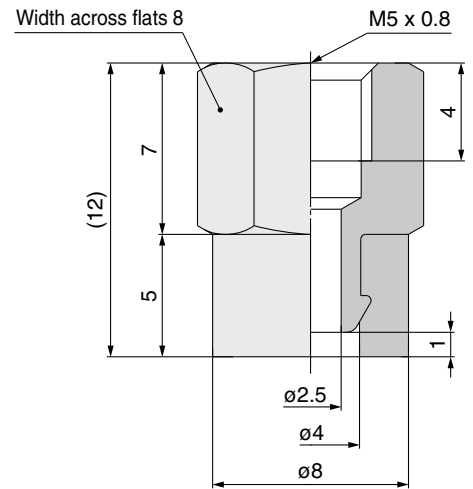

ZP2-T10S □ GC-B5

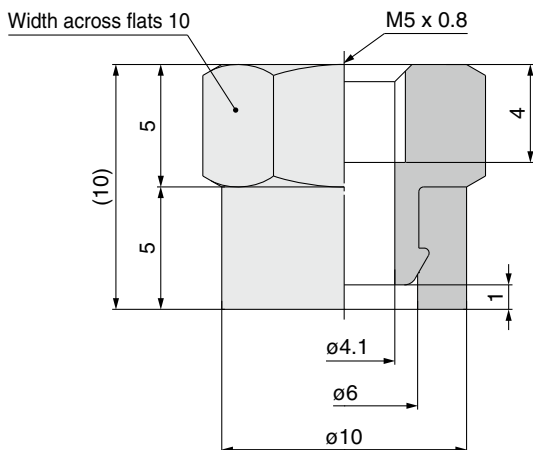

ZP2-T15S □ GC-B5

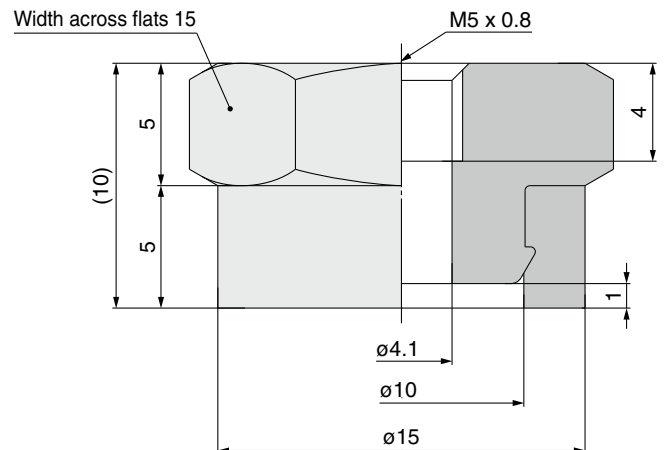

Model Selection

For Special Applications

Mark-free

For Film Adsorption

Multistage

Flat

Nozzle

Sponge

For Disk Adsorption

For Panel Holding

Ball Spine Buffer

Construction

Mounting Bracket Assembly

Precautions

Sponge Pad *ZP2 Series* Mounting Bracket Assembly

Adapter Assembly

Product part no.	<p>ZP2 - T ① S □ GC - ②</p> <p>Pad diameter Sponge Pad material Connection thread (Male/Female thread)</p> <p>Double-sided tape</p>
Component parts	<div style="display: flex; justify-content: space-around;"> <div style="text-align: center;"> <p>Male thread</p> <p>Ⓐ Adapter (With gasket) Ⓑ Gasket</p> </div> <div style="text-align: center;"> <p>Female thread</p> <p>Ⓐ Adapter</p> </div> </div>

		Symbol	① Pad diameter symbol					
			04	06	08	10	15	
Ⓐ Adapter	② Connection thread	Male thread	M3 x 0.5	A3	ZP2A-S01P	—		
		M5 x 0.8	A5	—	ZP2A-S02P	ZP2A-S03P	ZP2A-S04P	ZP2A-S05P
	Female thread	M3 x 0.5	B3	ZP2A-S11	—			
		M5 x 0.8	B5	—	ZP2A-S12	ZP2A-S13	ZP2A-S14	ZP2A-S15
Ⓑ Gasket (Single unit)		10 pcs.*1	M-3G2	ZP-5G2				
		100 pcs.*1		M-5G2				

*1 The gasket (single unit) sales unit is shown.

⚠ Sponge Pad/Specific Product Precautions

- Be sure to read this before handling the products.
- Refer to page 375 for safety instructions. For vacuum equipment and vacuum pad precautions, refer to pages 376 to 379.

Mounting

⚠ Caution

1. Attach the sponge pad with double-sided tape on the back after the adapter assembly mounting surface has been degreased and allowed to air dry.