

3-Step Setting (Switch Point Change Mode)

Simple setting of the switch point value (point at which the clearance reaches the switch point value)

Snap shot function

Pressing the Δ and ∇ buttons simultaneously for a minimum of 1 second then releasing the buttons when the displayed switch point value disappears will make the switch point the same as the current displayed value.



Features of the 2-Screen, 3-Color Digital Display

The seating condition can be checked at a glance. The sub screen can display 1 of 6 display options.

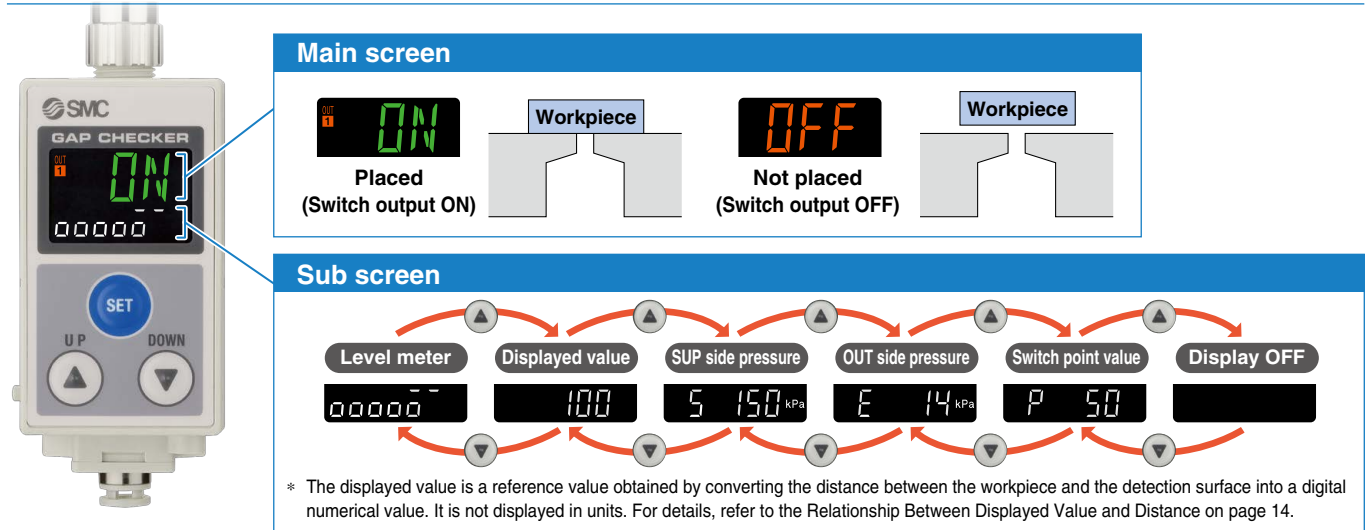

Improved Environmental Resistance

Easier maintenance

The internal orifice part can be removed for cleaning. It is not necessary to remove the piping or metal connection fitting for cleaning even when the product is installed in the user's equipment.



* Once the orifice has been removed, the switch point will need to be set again.

Measures against drainage

Drainage resistance: increased by **10 times** or more

* Based on SMC's specific testing conditions (Oil proof test)
* Compared with the ISA2

Withstand pressure increased by **3 times**^{*1} compared with the ISA2

Max.: 600 kPa

*1 Compared with the ISA2 with a 0.2 MPa pressure gauge

High-pressure flushing

* The switch output will be OFF during flushing.

Noise reduction

Energy saving

Measures against clogging

A Exhaust noise: **Noise reduction**
Zero

The current model (ISA2) needs to exhaust air from the exhaust port due to its bridge circuit. However, the ISA3 does not exhaust air from the product body. This reduces noise considerably compared with the current model.

B Air consumption: **Energy saving**
60% reduction^{*1}

The new detection principle eliminates the need for air to be exhausted from the product. This makes the flow consumption 0 L/min when a workpiece is seated. The result is a great reduction in air consumption compared with the current model.

^{*1} Conditions: Unseated for 5 seconds and seated for 20 seconds (For the G type)

Comparison of detection circuit

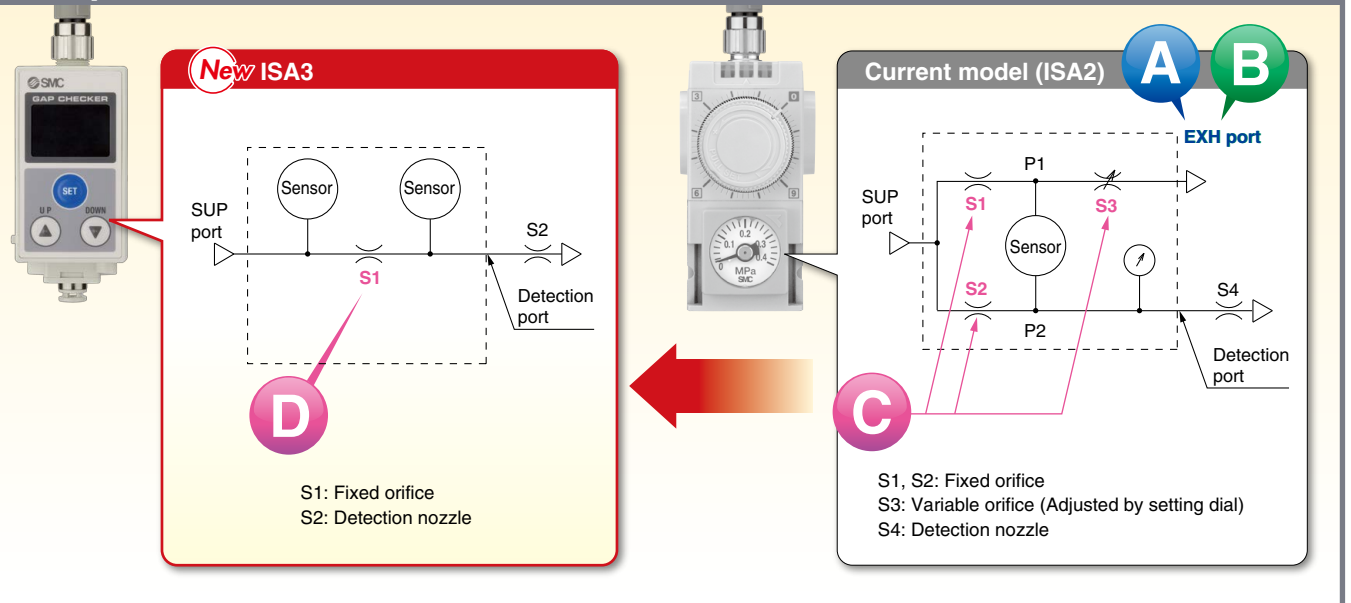

C Number of orifices: **Measures against clogging**
3 → 1

By reducing the number of internal orifices from 3 to 1, there is less possibility of fluctuations in the output due to clogging. By removing the setting dial for S3, fluctuations in the detection distance can be prevented.

D Orifice area ratio: **Measures against clogging**
68% increase^{*1}

A larger orifice area lowers the possibility of clogging. However, even if the orifice does become clogged with foreign matter, the product construction allows for the internal orifice to be removed for cleaning.

^{*1} Excludes the F type

2 Outputs Type

1. Outlet pressure, 2. Gap size, or 3. Supply pressure can be selected for OUT2.

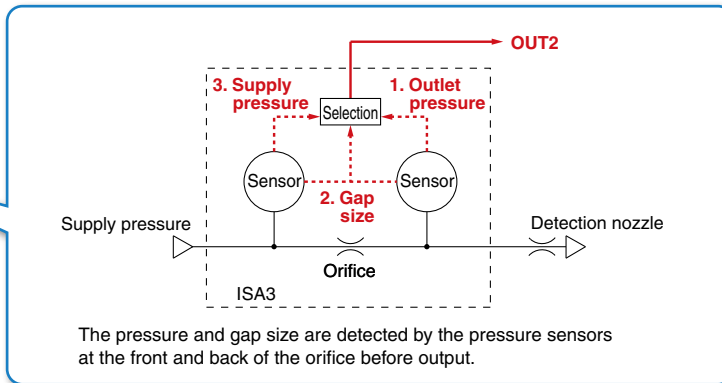

1. Monitoring of the Outlet Pressure

OUT2 detection of rising pressure when a workpiece is not placed that signifies detection nozzle clogging.

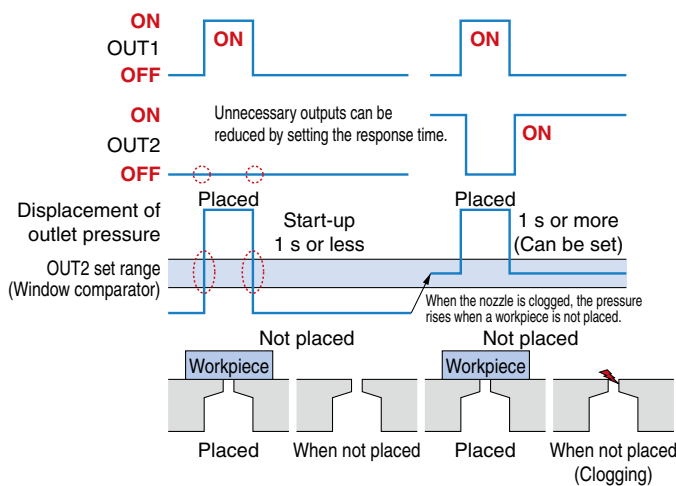

Only nozzle clogging can be detected by the window comparator mode and setting the response time.

Can discern between 2 different types of workpiece
Can detect raw material workpieces and defective workpieces via the **pressure (OUT2)**

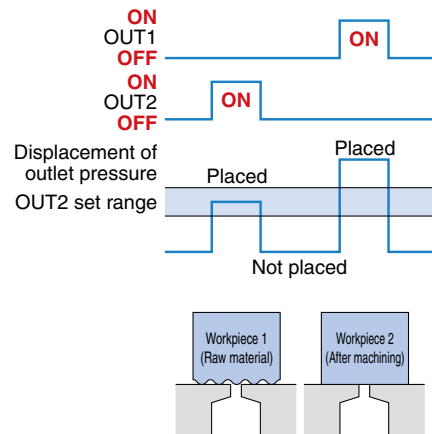

2. Monitoring of the Gap Size

Can discern between 2 different types of workpiece
Can detect the difference between raw material workpieces and defective workpieces via the **gap size**

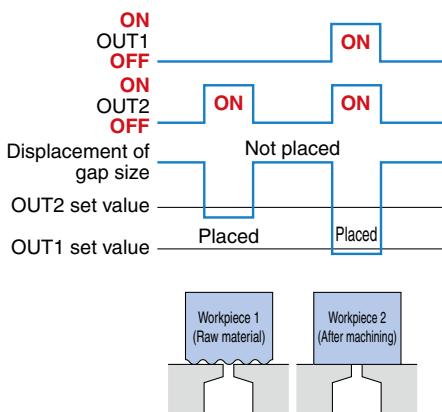

3. Monitoring of the Supply Pressure

Detection of rated pressure range via OUT2

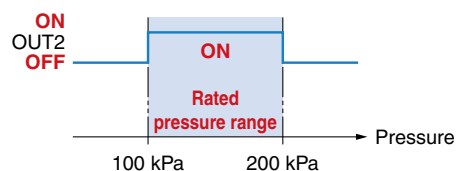

Compact & Lightweight

Volume: **40% reduction**

Weight: **55% reduction**

(Comparison between the ISA3-GC and the current model ISA2 with One-touch fitting)

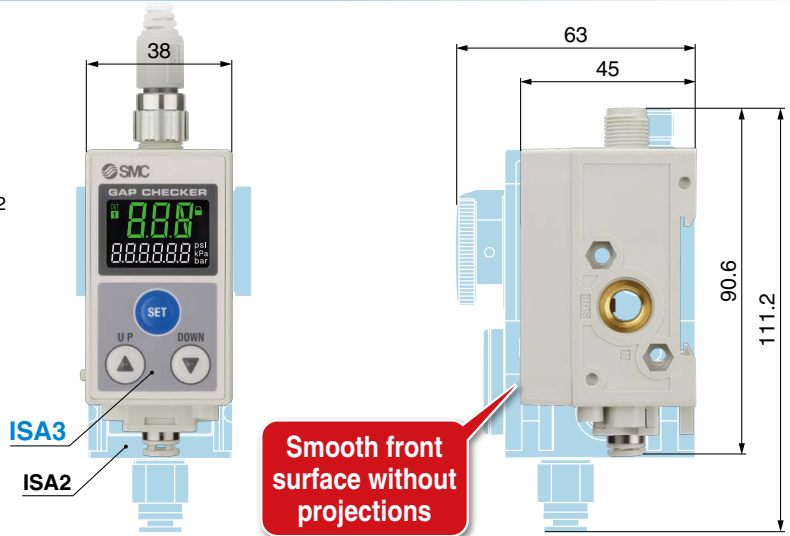

Space Saving & Reduced Wiring Labor (Centralized Lead Wire)

Installation space:
30 mm reduction

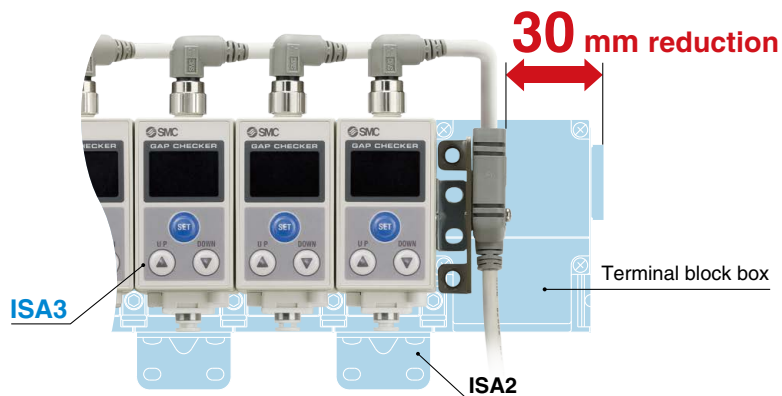

Requires less wiring labor

Current model

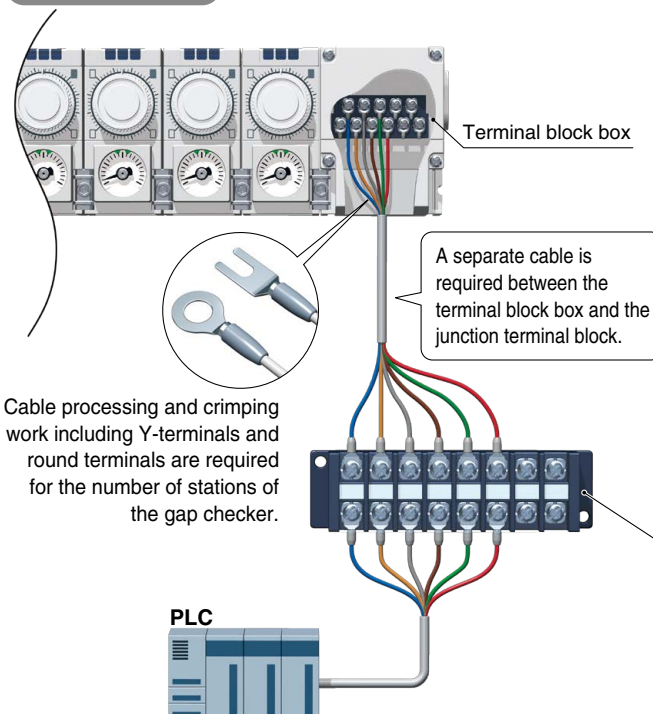

ISA3

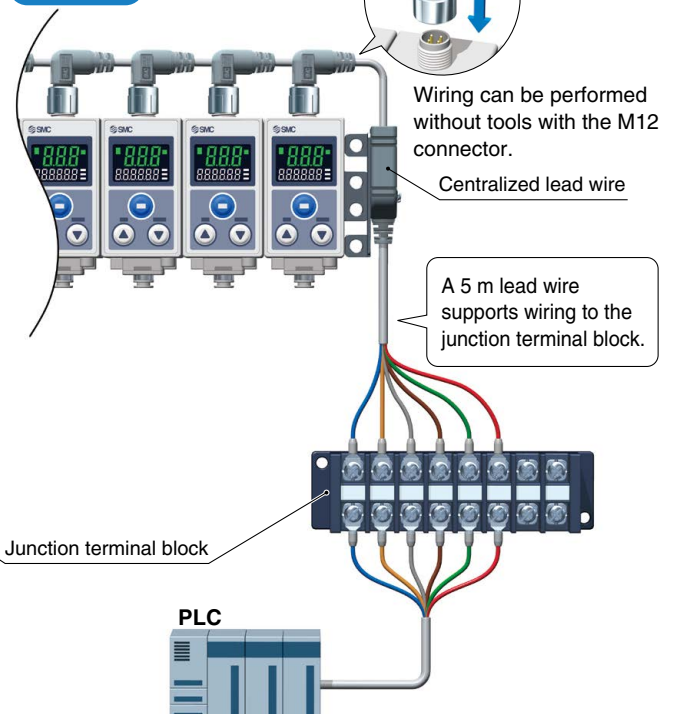

Keylock Function

A key LED turns ON when the product is locked and button operation is disabled to prevent unintentional changes to set values.



Piping Variations

Piping specification:
C type



Piping specification:
F type



Mounting

Bracket



DIN rail



Manifold

With control unit

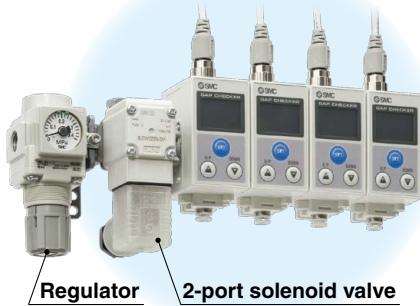

* Bracket mounting only

Without control unit



Centralized lead wire



Supply port: Left side

Centralized lead wire



Supply port: Right side

* The electrical entry of the centralized lead wire for the M12 connector is on the right side.
When using a right-sided supply port, arrange the centralized lead wire so that it does not interfere with the control unit.

Application Examples

Confirmation of the reference plane for the press fitting of shafts

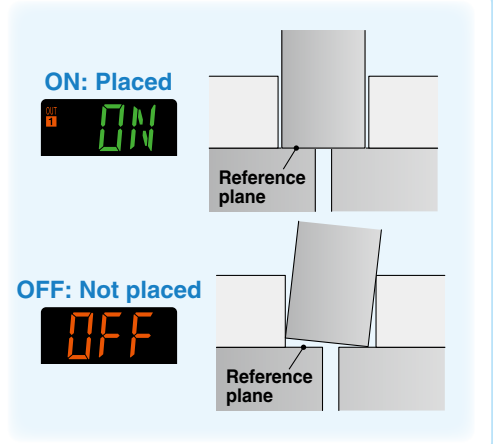
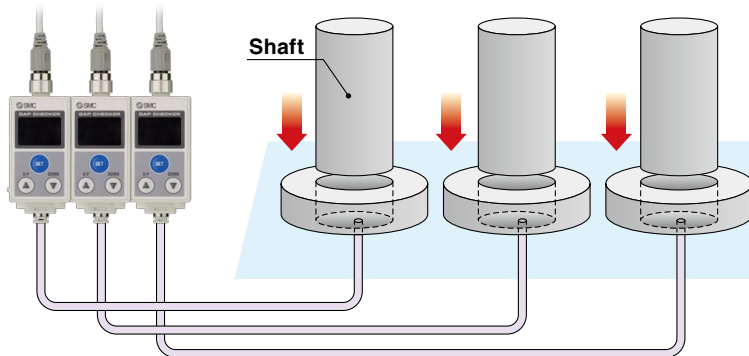

Confirmation of close contact with the reference plane for machining

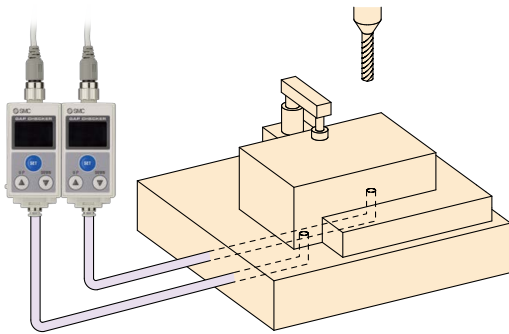

Confirmation of close contact with the workpiece for machining

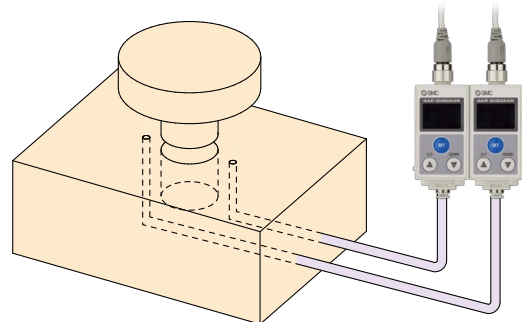

Main Functions

Display OFF mode

Display OFF mode can be selected. The display can be turned OFF to reduce power consumption.



Security code

When the security code is activated, the code needs to be entered before the product can be operated.



Security code:
Input an arbitrary 3-digit code.

Display color

The color of the main display can be set to change depending upon the output activity. The display color change makes visual identification of the output ON/OFF easier.

When ON: Green	When OFF: Orange
When ON: Orange	When OFF: Green
Normally: Orange	
Normally: Green	

Unit conversion

The pressure unit displayed on the sub screen can be changed.

Display unit	kPa	bar	psi
Minimum setting resolution	1	0.01	0.1

Displayed value compensation

The displayed value can be corrected within $\pm 20\%$ R.D. of the displayed value at the time of shipment.

Forced output

The output can be fixed to an ON/OFF state when starting the system or during maintenance. This enables the confirmation of the wiring and prevents system errors due to unexpected output.

Zero-clear of pressure value

The pressure value displayed on the sub screen can be cleared to zero.

CONTENTS

ISA3 Series

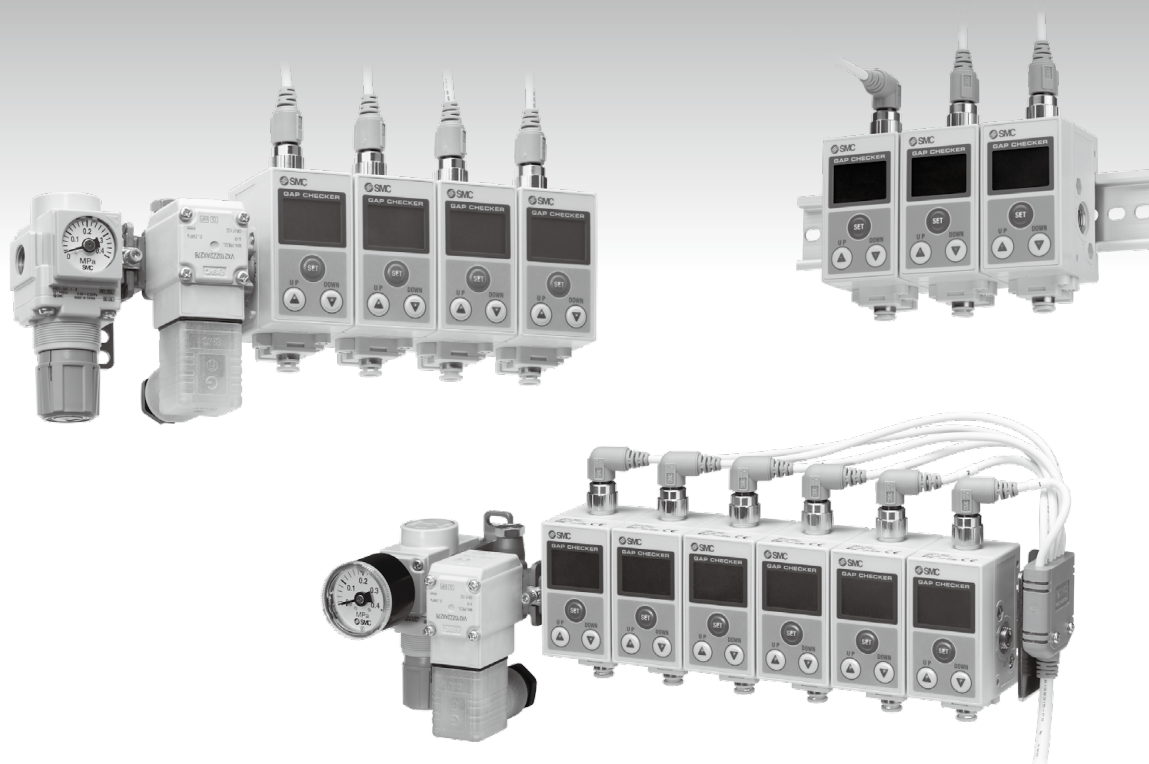

● 3-Color Display Digital Gap Checker ISA3 Series

How to Order (Without Control Unit)	p. 9
How to Order (With Control Unit)	p. 10
Specifications	p. 11
Supply Pressure Dependence Characteristics	p. 12
Response Time	p. 13
Relationship Between Displayed Value and Distance	p. 14
Detection Nozzle Shape	p. 14
Internal Circuits and Wiring Examples	p. 14
Construction Diagram	p. 15, 16
Parts List	p. 17, 18
Dimensions	p. 19 to 21-1
Error Indication	p. 22
Relationship Between Supply Pressure and Display	p. 22

3-Color Display Digital Gap Checker Without Control Unit ISA3 Series



How to Order

ISA3-GCN-M2

Rated distance range

F	0.01 to 0.03 mm
G	0.02 to 0.15 mm
H	0.05 to 0.30 mm

Piping specifications

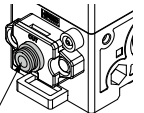
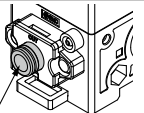
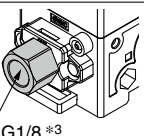
	Supply side	Detection side
C	Rc1/8	 ø4 One-touch fitting *1
		 ø6 One-touch fitting *2
F	G1/8 *3	 G1/8 *3

- *1 When F is selected for the rated distance range
- *2 When G or H is selected for the rated distance range
- *3 Conforming to ISO 1179-1

Output specifications

N	NPN 1 output
P	PNP 1 output
A *11	NPN 2 outputs
B *11	PNP 2 outputs

- *11 2 switch outputs type
OUT1: Gap size detection
OUT2: Gap size, outlet pressure, supply pressure detection (Select from the above.)

Unit specifications of pressure value

Nil	With unit conversion function *9
M	Fixed SI unit *10

- *9 Under the New Measurement Act, digital gap checkers with the unit conversion function are not permitted for use in Japan.
- *10 Unit: kPa

Stations

1	1 station
2	2 stations
3	3 stations
4	4 stations
5	5 stations
6	6 stations

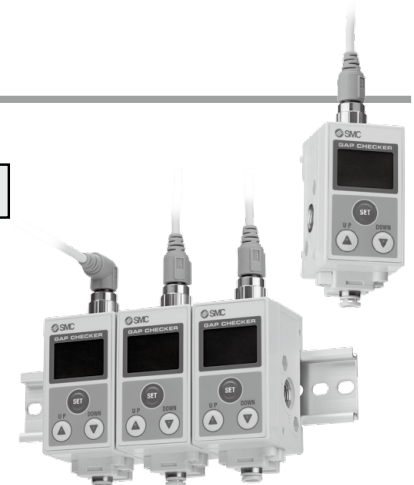

Option 2 (Bracket)

Nil	None (DIN rail mounting) *7
B	With bracket *5 *8

- *7 Order DIN rail separately. (Refer to page 17.)
- *8 About the number of brackets, 1 station: 1 piece is packed, 2 stations or more: 2 pieces are packed.

Bracket mounting position

2 stations
(Mount to 1st and 2nd stations)



n stations
(Mount to 1st and nth stations)

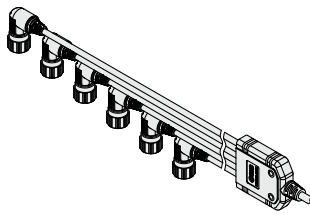
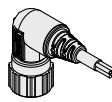

Option 1 (Cable)

Nil	Straight *5 *6		S	Centralized lead wire (Lead wire only) *4 *5	
L	Right angle *5 *6			T	Centralized lead wire (With bracket) *4 *5

- *4 Cannot be selected for 1 station. One set is provided per manifold. A centralized lead wire is provided with M12 connectors for the number of stations. Refer to page 21 for details.
- *5 At the factory, the options are not attached to the product, but packed together with it for shipment.
- *6 Cables are provided for the number of stations.

3-Color Display Digital Gap Checker With Control Unit ISA3 Series



How to Order

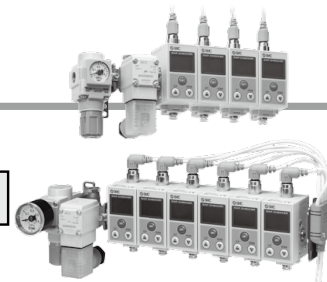

ISA3 - **G** **C** **N** - **M** **2** **B** - **L** **1**

Rated distance range

F	0.01 to 0.03 mm
G	0.02 to 0.15 mm
H	0.05 to 0.30 mm

Piping specifications

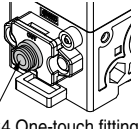
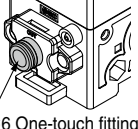
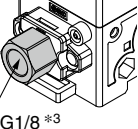
	Supply side	Detection side
C	Rc1/8	 ø4 One-touch fitting *1
		 ø6 One-touch fitting *2
F	G1/8 *3	 G1/8 *3

- *1 When F is selected for the rated distance range
- *2 When G or H is selected for the rated distance range
- *3 Conforming to ISO 1179-1

Output specifications

N	NPN 1 output
P	PNP 1 output
A *14	NPN 2 outputs
B *14	PNP 2 outputs

- *14 2 switch outputs type
OUT1: Gap size detection
OUT2: Gap size, outlet pressure, supply pressure detection (Select from the above.)

Unit specifications of pressure value

Nil	With unit conversion function *12
M	Fixed SI unit *13

- *12 Under the New Measurement Act, digital gap checkers with the unit conversion function are not permitted for use in Japan.
- *13 Unit: kPa

Stations

1	1 station
2	2 stations
3	3 stations
4	4 stations
5	5 stations
6	6 stations

Option 1 (Cable)

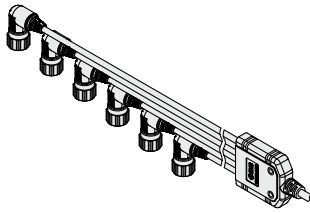
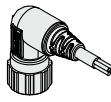
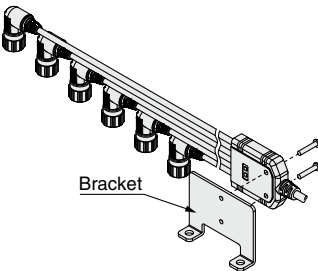
Nil	Straight *5 *6 	S	Centralized lead wire (Lead wire only) *4 *5 
L	Right angle *5 *6 		Centralized lead wire (With bracket) *4 *5 
N	None	T	

- *4 Cannot be selected for 1 station. One set is provided per manifold. A centralized lead wire is provided with M12 connectors for the number of stations. Refer to page 21 for details.
- *5 At the factory, the options are not attached to the product, but packed together with it for shipment.
- *6 Cables are provided for the number of stations.

2-port solenoid valve rated voltage

Nil	24 VDC
1 *11	100 VAC
2 *11	110 VAC

- *11 Produced upon receipt of order

Regulator (Refer to page 18.)

N *10		Without regulator		
0 *10		Without pressure gauge		
1	Round type pressure gauge	0.4 MPa	MPa single notation	
	Square type pressure gauge			
	2	Round type pressure gauge		0.2 MPa
		Square type pressure gauge		
3	Round type pressure gauge	0.4 MPa	MPa-psi double notation	
	Square type pressure gauge			
4	Round type pressure gauge	0.2 MPa		
	Square type pressure gauge			
5 *10	Round type pressure gauge	0.4 MPa	psi single notation	
	Square type pressure gauge			
6 *10	Round type pressure gauge	0.2 MPa		
	Square type pressure gauge			
7 *10	Round type pressure gauge	0.4 MPa	MPa-psi double notation	
	Square type pressure gauge			
8 *10	Round type pressure gauge	0.2 MPa		
	Square type pressure gauge			

- *10 Produced upon receipt of order

Control unit (Regulator, 2-port valve)

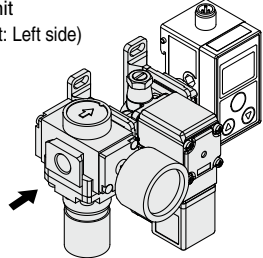
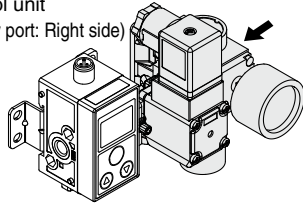
L	Control unit (Supply port: Left side) 
R	Control unit (Supply port: Right side) 

Control unit piping specifications *8

Gap checker piping specifications	Supply port piping specifications
C	Rc1/4
F	G1/4 *9

- *8 When the control unit is mounted, the piping specifications of the supply port will be changed due to piping specification of the gap checker.
- *9 Conforming to ISO 16030

Option 2 (Bracket)

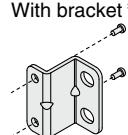
B	With bracket *7 
----------	--

- *7 The bracket for control unit is shipped mounted on the product.

For gap checker precautions and specific product precautions, refer to the "Operation Manual" on the SMC website. Click [here](#) for details.

Specifications

Model		ISA3-F	ISA3-G	ISA3-H
Applicable fluid		Dry air (Filtered through a 5 μm filter)		
OUT1 OUT2 *5	Rated distance range	0.01 to 0.03 mm	0.02 to 0.15 mm	0.05 to 0.30 mm
	Displayable/Settable range (Distance reference) *1	0 to 60 *2	10 to 300 *2	30 to 500 *2
	Minimum display resolution (Distance reference) *1	1		
	Rated pressure range	100 to 200 kPa		
	Displayable range (Pressure value) *3	-20 to 220 kPa		
	Repeatability	0.005 mm or less	0.010 mm or less	0.020 mm or less
	Temperature characteristics (Reference: 25°C)	0.010 mm or less	0.015 mm or less	0.030 mm or less
Hysteresis	0 to variable (Default: 3)	0 to variable (Default: 20)		
OUT2 *6	Rated pressure range	0 to 200 kPa		
	Set pressure range	-20 to 220 kPa		
	Minimum display/setting resolution	1 kPa		
	Repeatability	±0.5% F.S. ±1 digit		
	Temperature characteristics (Reference: 25°C)	±2% F.S.		
Hysteresis	0 to variable *7			
Withstand pressure		600 kPa		
Detection nozzle		ø1.5 *4		
Consumption flow rate		5 L/min or less	12 L/min or less	22 L/min or less
Power supply voltage		24 VDC ±10%, Ripple (p-p) 10% or less (With power supply polarity protection)		
Current consumption		25 mA or less		
Switch output		1 output (NPN or PNP), 2 outputs (NPN or PNP)		
		Maximum load current		
		10 mA		
		Maximum applied voltage		
		26.4 V		
		Residual voltage		
		1 V or less (at 10 mA)		
		Short-circuit protection		
		Provided		
Display		2-screen display, LCD Main screen: 3-digit, 7-segment, 2-color (Orange/Green) Sub screen: 6-digit, 7-segment, 1-color (White)		
Environmental resistance	Enclosure		IP67 equivalent *8	
	Operating temperature range		Operating: 0 to 50°C, Stored: -20 to 70°C (No condensation or freezing)	
	Operating humidity range		Operating/stored: 35 to 85% RH (No condensation)	
	Withstand voltage		1000 VAC or more (in 50/60 Hz) for 1 minute between terminals and housing	
Insulation resistance		2 MΩ or more (500 VDC measured via megohmmeter) between terminals and housing		
Piping specifications	For C type	Supply port	Rc1/8	
		Detection port	ø4 One-touch fitting	ø6 One-touch fitting
	For F type	Supply port	G1/8 (Compliant with ISO 1179-1)	
		Detection port	G1/8 (Compliant with ISO 1179-1)	
Cable	Lead wire with connector		M12 lead wire with 4 pin connector, 4 cores, ø4, 5 m Conductor O.D.: 0.72 mm, Insulator O.D.: 1.14 mm	
	Centralized lead wire	M12 lead wire with 4 pin connector section	4 cores, ø4, Insulator O.D.: 1.14 mm	
		Centralized lead wire section	2 to 3 stations (1 output) 5 cores, ø4, 5 m 2 to 3 stations (2 outputs) 8 cores, ø6, 5 m 4 to 6 stations (1 output) 8 cores, ø6, 5 m 4 to 6 stations (2 outputs) 14 cores, ø6, 5 m Conductor O.D.: 0.50 mm, Insulator O.D.: 1.00 mm (2 to 6 stations common)	
Weight		113 g (Cable not included, One-touch fitting)		
Standards		CE/UKCA marking		

- *1 For details, refer to the Relationship Between Displayed Value and Distance on page 14.
- *2 If hysteresis is set to 3 (Default setting), the "Displayable/Settable range" of the F type is limited to 57. If hysteresis is set to 20 (Default setting), the G type is limited to 280 and the H type is limited to 480.
- *3 The pressure value will be the indicated on the sub screen.
- *4 For details on the detection nozzle, refer to the figures on page 14.

- *5 Refers to when OUT2 is set to detect the distance
- *6 Refers to when OUT2 is set to detect the pressure
- *7 If the applied pressure fluctuates around the set value, the hysteresis must be set to a value more than the fluctuating width, otherwise chattering will occur.
- *8 Only applies to the digital gap checker body excluding the control unit.

Rated Distance Range and Displayable/Settable Range

⚠ Caution

The displayed value is a reference value obtained by converting the distance between the workpiece and the detection surface into a digital numerical value. It is not displayed in units.

For details, refer to the Relationship Between Displayed Value and Distance on page 14.

Rated distance range: Distance range within which the product meets the specifications

Displayable/Settable range: Range within which it is possible to display or set values, (Not guaranteed to meet the specifications)

Model	Distance				
	0 mm	0.02 mm	0.05 mm	0.15 mm	0.30 mm
ISA3-F type	[Bar chart showing ranges for ISA3-F type]				
ISA3-G type	[Bar chart showing ranges for ISA3-G type]				
ISA3-H type	[Bar chart showing ranges for ISA3-H type]				

■ Rated distance range ■ Displayable/Settable range

Supply Pressure Dependence Characteristics

The distance for the product to turn ON varies depending on the supply pressure.

The graphs below show the variation of the distance for the product to turn ON, for 3 types of gap, by changing the supply pressure (± 50 kPa) when the product is set to turn ON at 150 kPa supply pressure.

Test conditions	Detection nozzle: $\phi 1.5$ Piping: F type $\phi 4 \times \phi 2.5$ tube/G, H type $\phi 6 \times \phi 4$ tube Reference pressure: 150 kPa
------------------------	---

* Use within the rated pressure range (100 kPa to 200 kPa).

It will be impossible to measure the gap when the operating pressure is less than 80 kPa or over 220 kPa. And the output will be OFF.
(Refer to the Relationship Between Supply Pressure and Display on page 22.)

ISA3-F

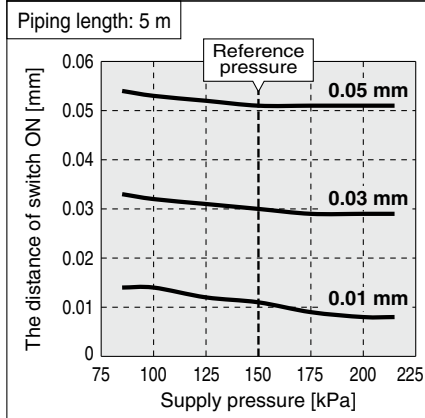
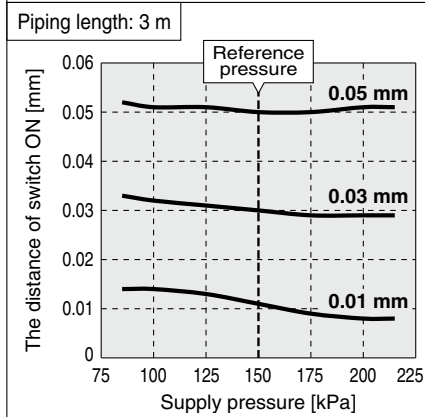
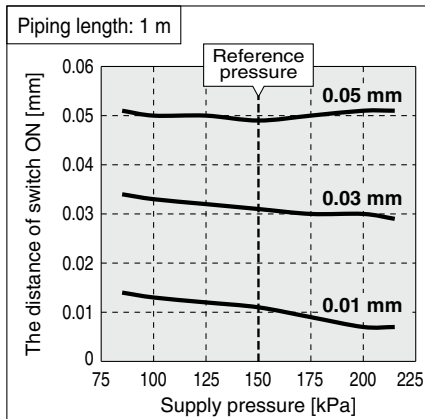

ISA3-G

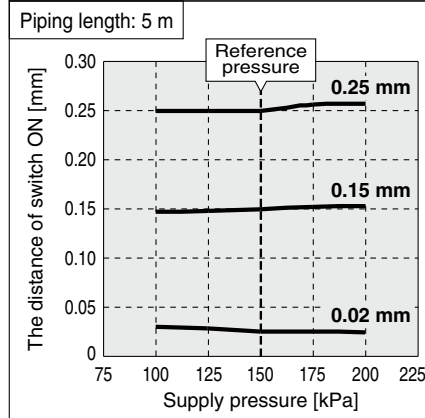
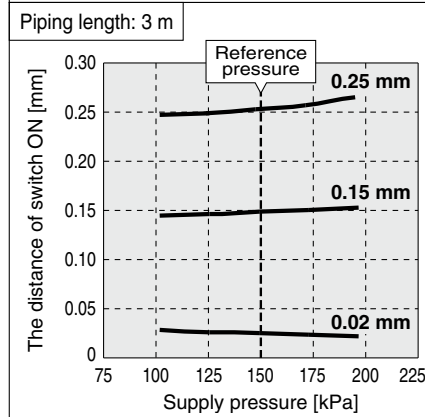
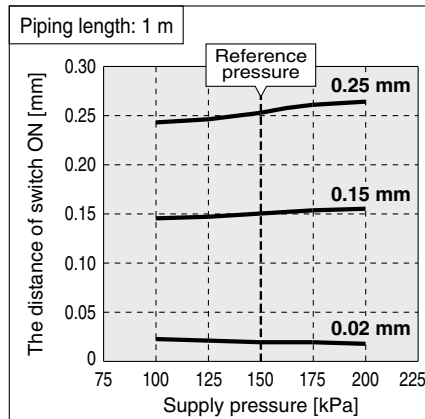

ISA3-H

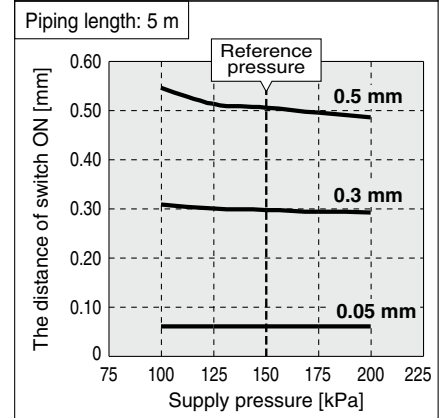
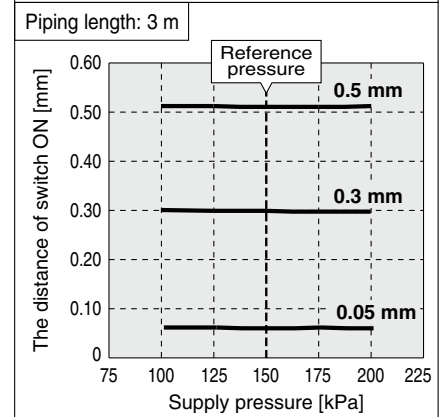
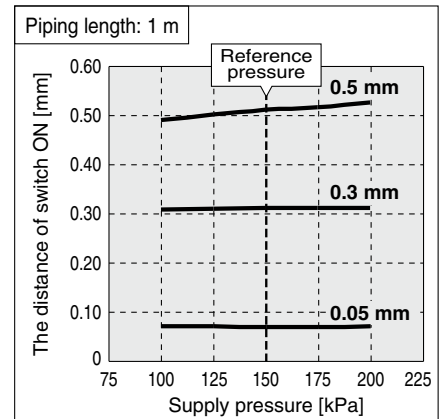

Response Time

Response time is the elapsed time between the pressure supply and the turning ON of the switch output.

The response time varies depending on the piping length from the OUT port to the detection nozzle, and the seating condition of the workpiece. The graphs below show the response time when the workpiece is approached at 90% distance and 0% distance (close contact). (* The switch point is 100% distance.)

(Example: When the switch point is set to 0.1 mm, the response time when the workpiece is at 0.09 mm and 0 mm are measured.)

Test conditions	Detection nozzle: $\varnothing 1.5$ Piping: F type $\varnothing 4 \times \varnothing 2.5$ tube/G, H type $\varnothing 6 \times \varnothing 4$ tube Supply pressure: 200 kPa
------------------------	---

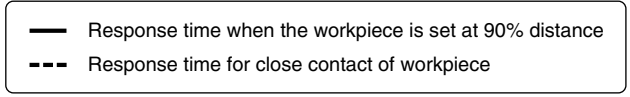

ISA3-F

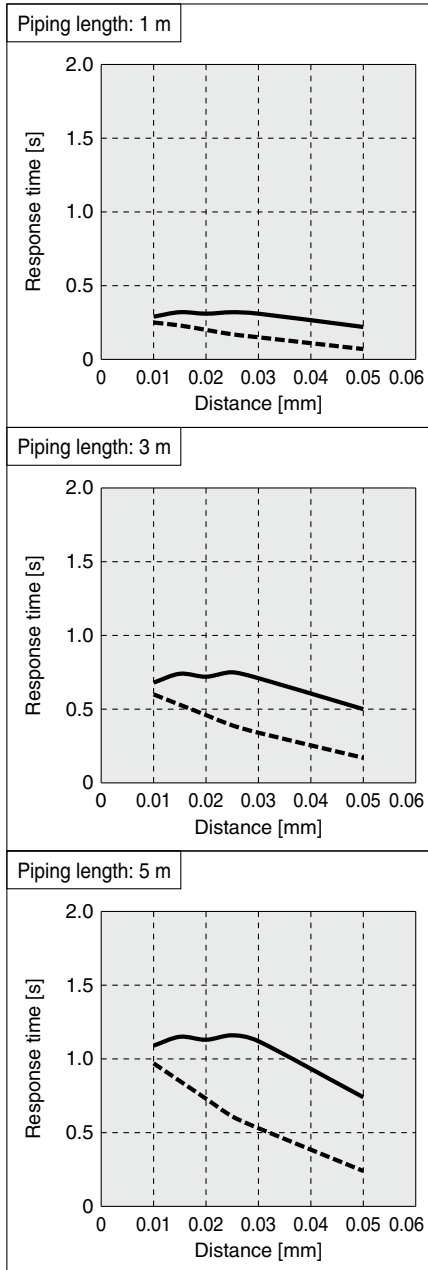

ISA3-G

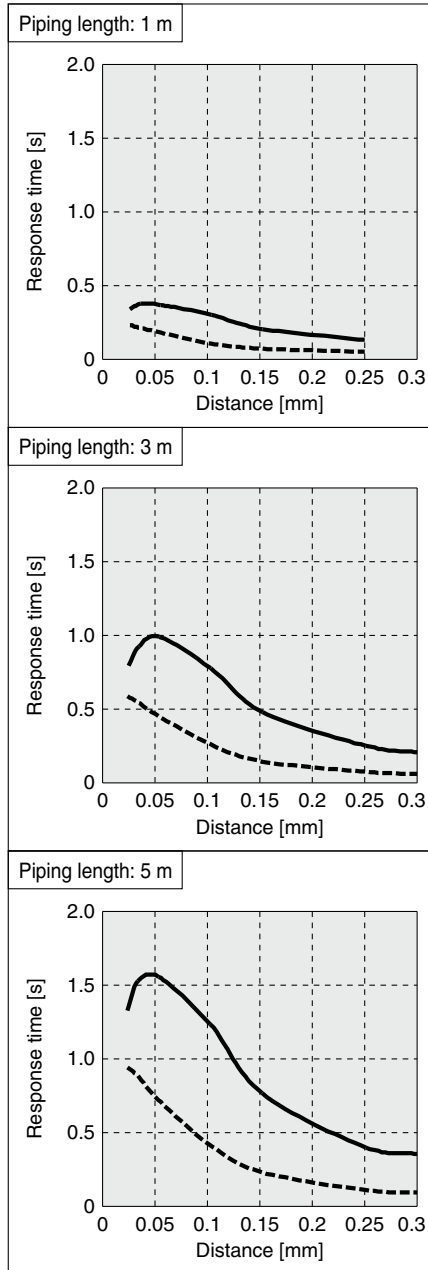

ISA3-H

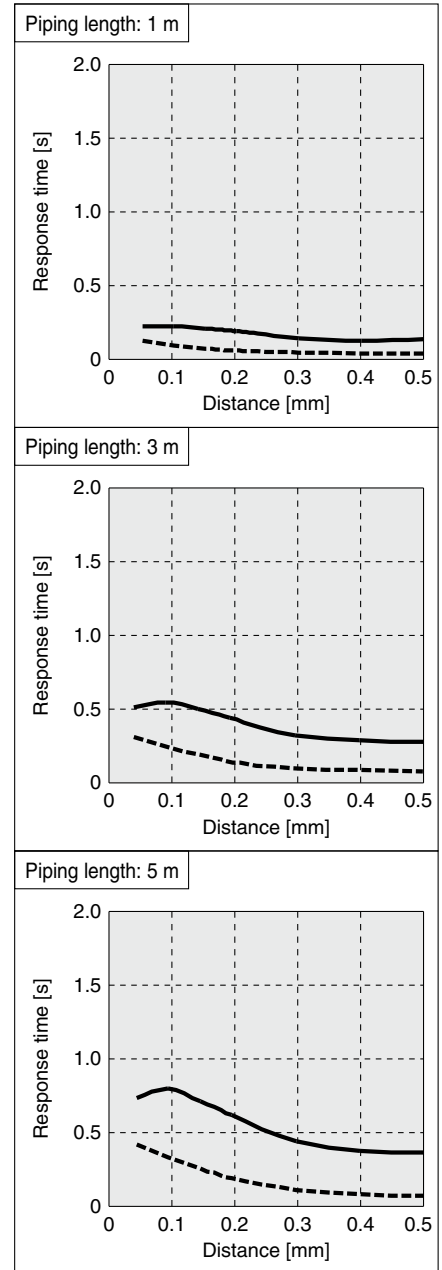

Relationship Between Displayed Value and Distance

The graphs below show the relationship between the displayed value and distance.

* The data shown below are for reference. They change depending on the individual product differences, machining dimensions of the nozzle, etc.

Test conditions	Detection nozzle: $\phi 1.5$
	Detection nozzle piping:
	F type $\phi 4 \times \phi 2.5$ tube 1 m, 3 m, 5 m/ G, H type $\phi 6 \times \phi 4$ tube 1 m, 3 m, 5 m
	Supply pressure: 200 kPa

ISA3-F

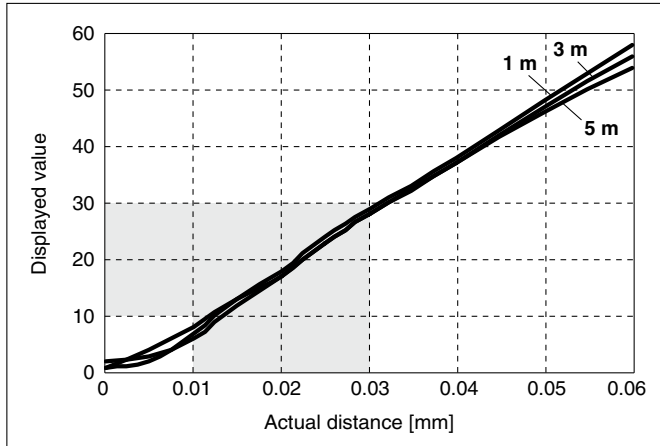

ISA3-G

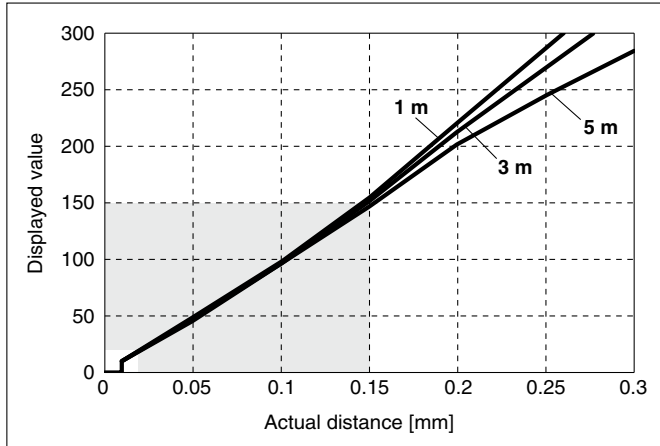

* Values of 9 and under are displayed as "0."

ISA3-H

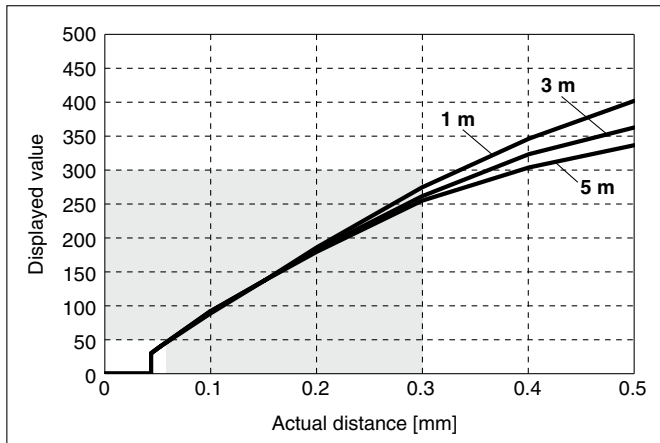

* Values of 29 and under are displayed as "0."

Detection Nozzle Shape

The nozzle shape must be similar to Fig. 1.

Do not chamfer the nozzle as shown in Fig. 2, as the characteristics will be affected.

Fig. 1: Recommended nozzle shape

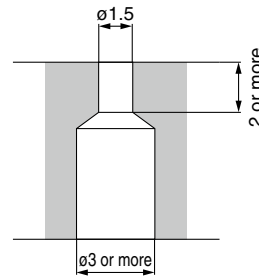
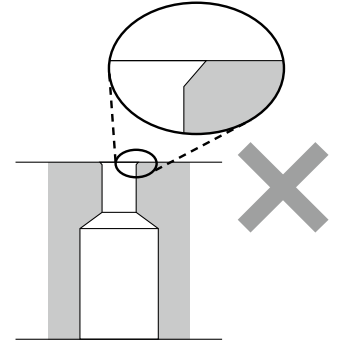
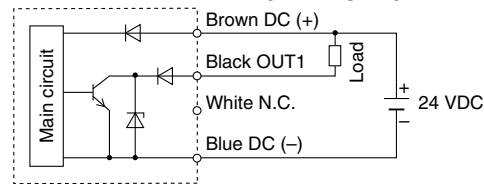

Fig. 2: Unsuitable nozzle shape



Internal Circuits and Wiring Examples

ISA3-□□N NPN (1 output)



ISA3-□□P PNP (1 output)

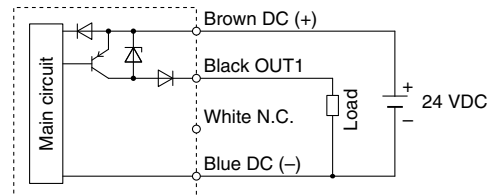

ISA3-□□A NPN (2 outputs)

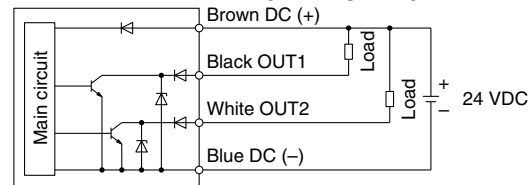

ISA3-□□B PNP (2 outputs)

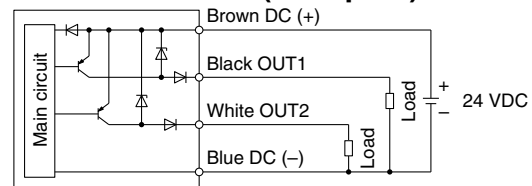

* Refer to the **Web Catalog** for wiring details of the VX2 series (2-port solenoid valve).

ISA3 Series

Construction Diagram

Without control unit

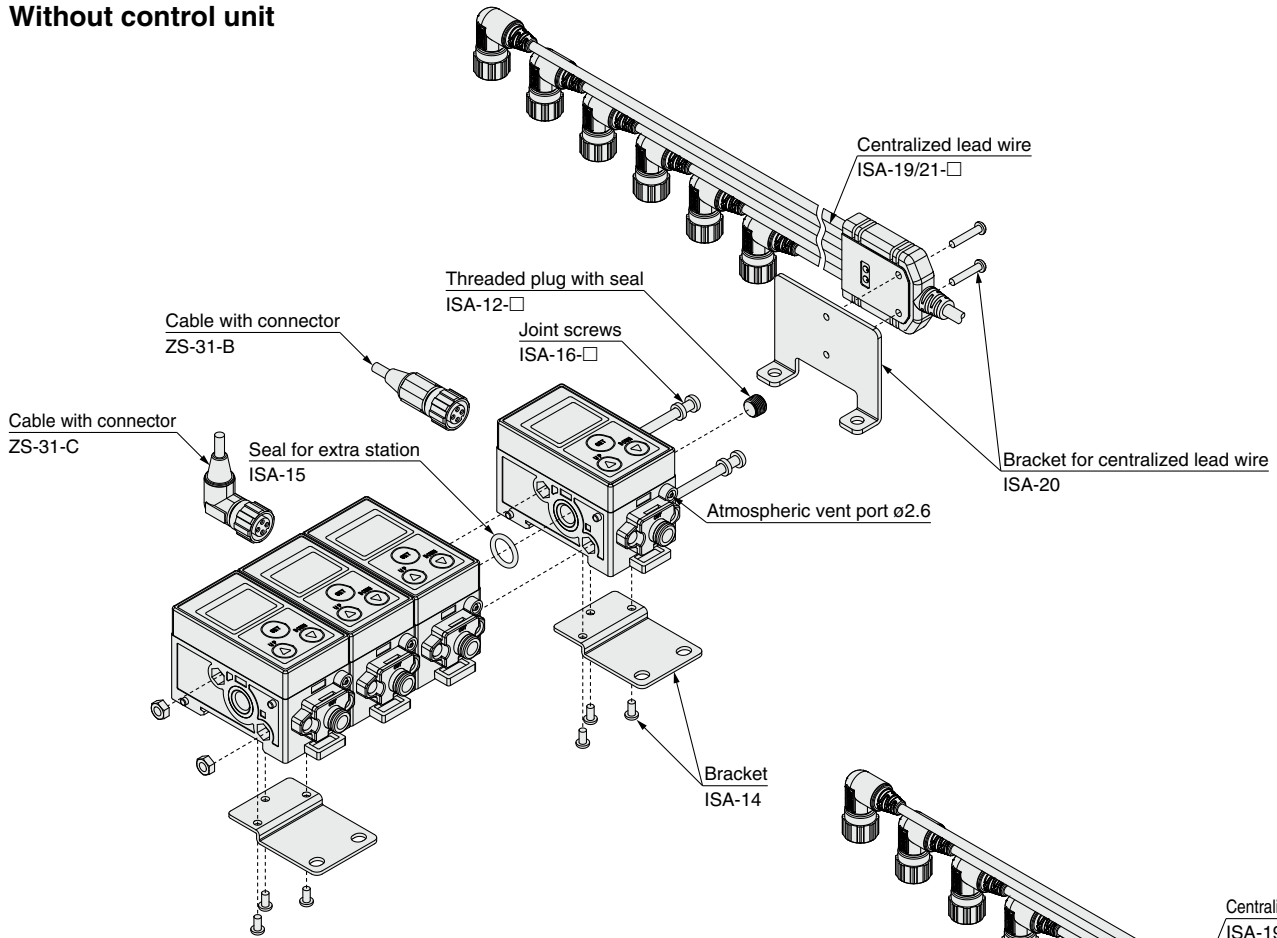

With control unit Supply port: Left side

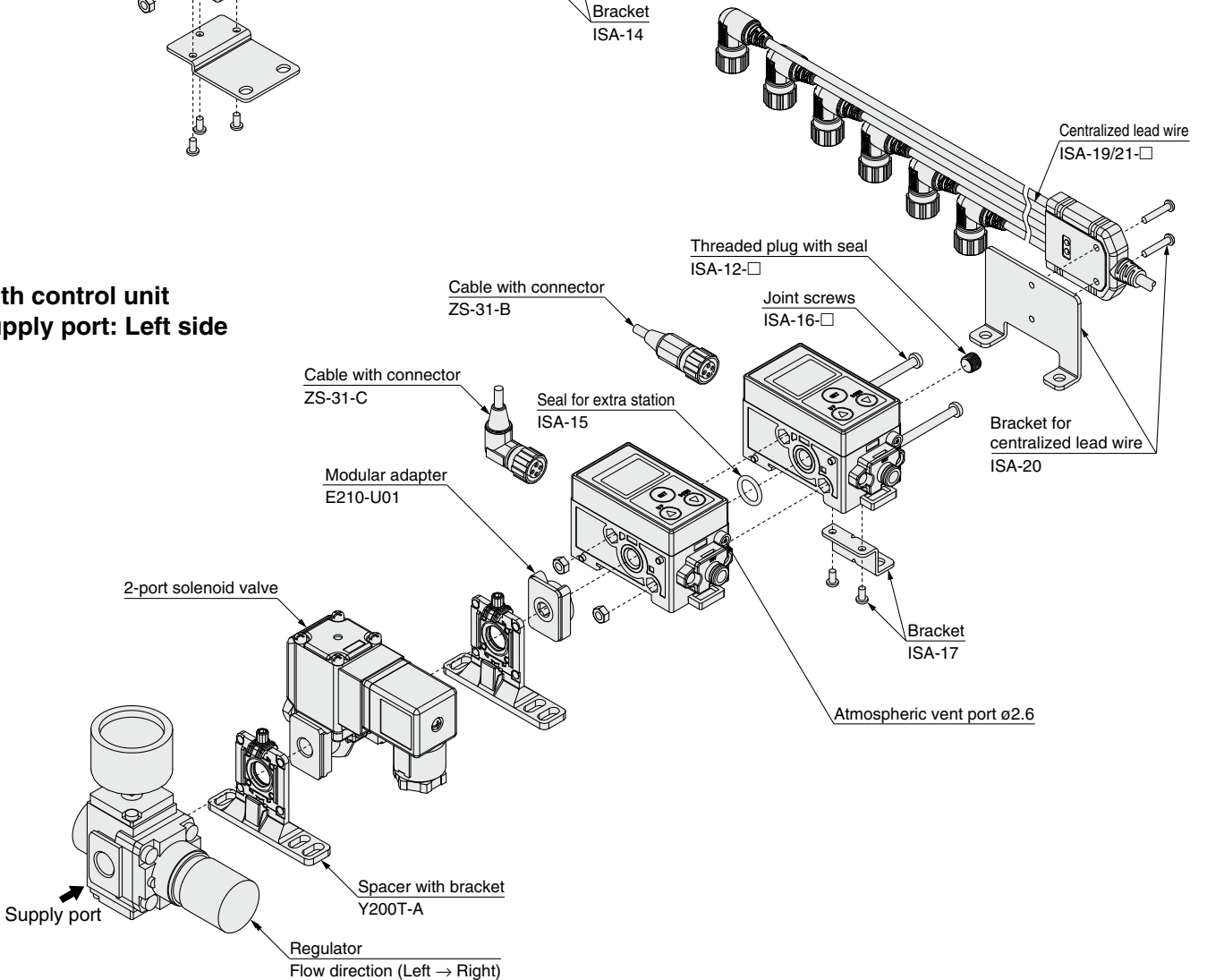

Construction Diagram

With control unit
Supply port: Right side

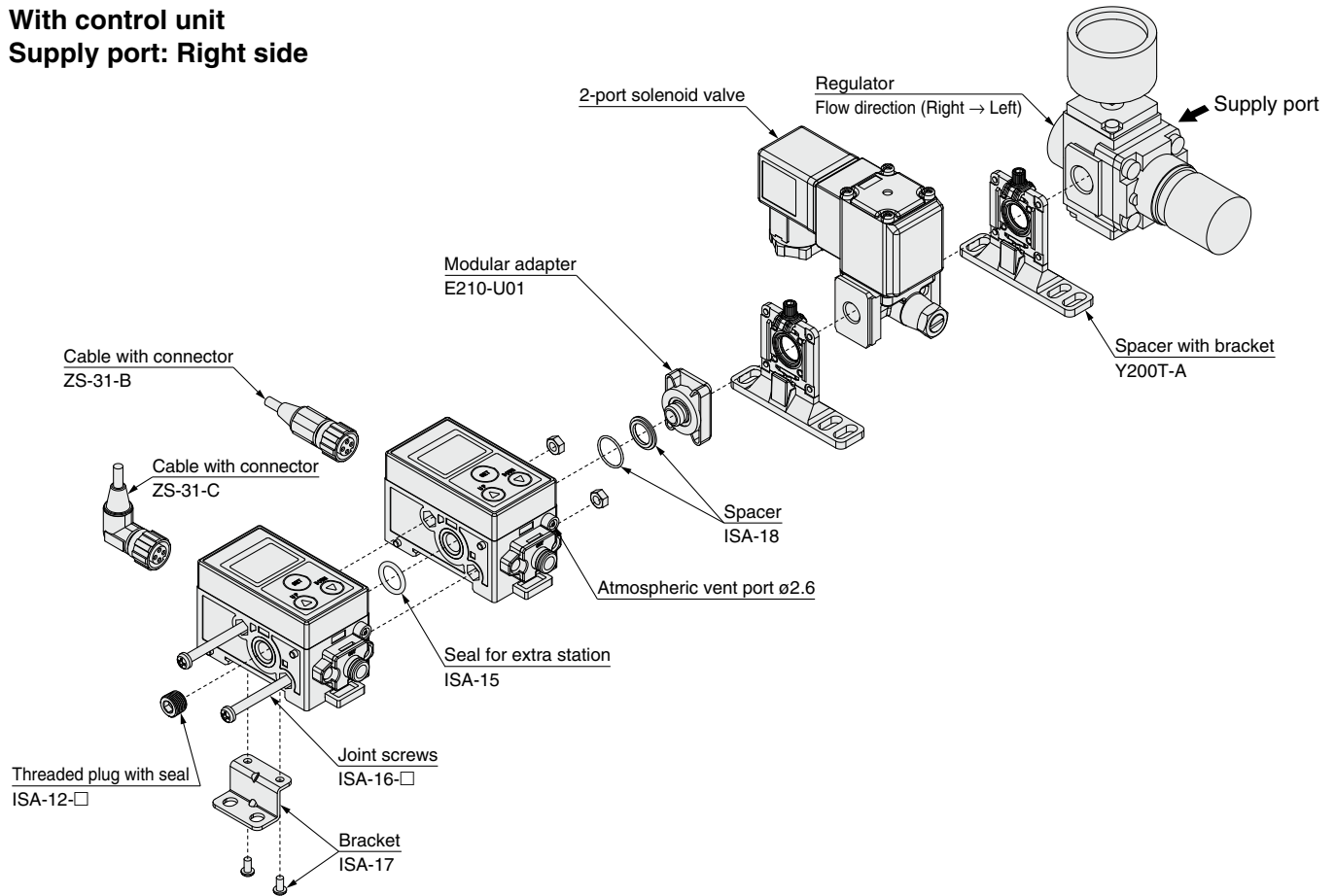

If there is a possibility that the atmospheric vent port of the gap checker will be exposed to water or dust, insert a tube into the atmospheric vent port and route the other end of the tube to a safe place away from water or dust.

* For tubing, please use the SMC TU0425 (polyurethane, O.D. ø4, I.D. ø2.5) for the gap checker.

⚠ Caution

SMC products are not intended for use as instruments for legal metrology.

Measurement instruments that SMC manufactures or sells have not been qualified by type approval tests relevant to the metrology (measurement) laws of each country. Therefore, SMC products cannot be used for business or certification ordained by the metrology (measurement) laws of each country.

ISA3 Series

Parts List

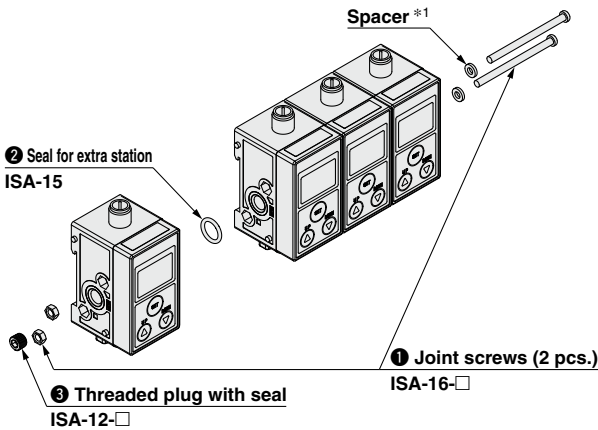

*1 Spacers are included for 4 and 6 stations.

- 1 Joint screws**
2 screws,
2 spacers, 2 nuts

Stations	Part no.
2	ISA-16-2
3	ISA-16-3
4 *1	ISA-16-4
5	ISA-16-5
6 *1	ISA-16-6

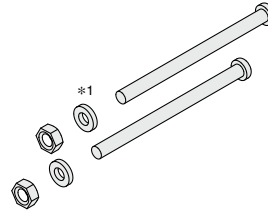

- 2 Seal for extra station**
ISA-15 1 pc.



- 3 Threaded plug with seal**
ISA-12-□ 1 pc.

Piping	Part no.
Rc1/8	ISA-12-A
G1/8	ISA-12-C



Bracket ISA-14

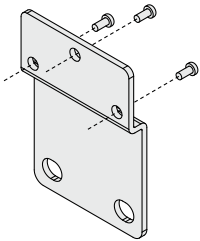

With 3 tapping screws (3 x 8)

DIN rail ISA-5-1

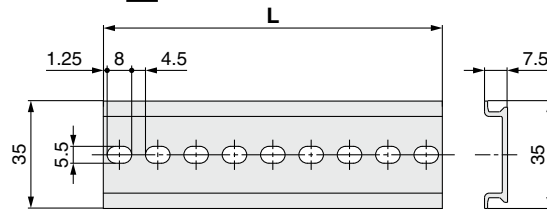

Stations	Part no.	L
1	ISA-5-1	73.0
2	ISA-5-2	135.5
3	ISA-5-3	173.0
4	ISA-5-4	210.5
5	ISA-5-5	248.0
6	ISA-5-6	285.5

Lead wire with connector ZS-31-B ZS-31-C

Straight 5 m

Right angle 5 m

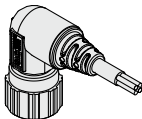

Centralized lead wire ISA-19/21-2

Stations	Part no.	
	1 output	2 outputs
2	ISA-19-2	ISA-21-2
3	ISA-19-3	ISA-21-3
4	ISA-19-4	ISA-21-4
5	ISA-19-5	ISA-21-5
6	ISA-19-6	ISA-21-6

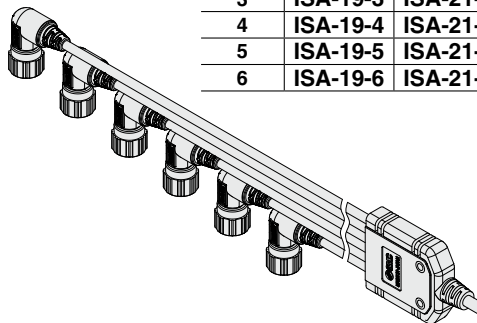

Bracket for centralized lead wire ISA-20

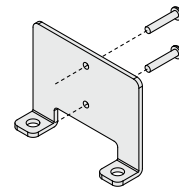

* With 2 mounting screws (M3 x 16L)

Parts List (Control Unit)

■ Regulator

AR20 - [] 02 [] - 1 [] - B []

● Pipe thread type

Nil	Rc
F	G

● Flow direction

Nil	Flow direction: Left → Right
R	Flow direction: Right → Left

● Option (Pressure gauge shape)

Nil	Without pressure gauge	Nil	Max. display pressure of the pressure gauge
		Nil	—
E	With square embedded type pressure gauge (With limit indicator)	Nil	Max. display pressure: 0.4 MPa, MPa single notation
		-X2105	Max. display pressure: 0.2 MPa, MPa single notation
		-X2176	Max. display pressure: 60 psi (0.4 MPa), psi single notation *2
		-X2175	Max. display pressure: 30 psi (0.2 MPa), psi single notation *2
G *1	With round type pressure gauge (With limit indicator, MPa single notation)	Nil	Max. display pressure: 0.4 MPa
		-X2105	Max. display pressure: 0.2 MPa
P *1	With round type pressure gauge (With limit indicator, MPa-psi double notation *2)	Nil	Max. display pressure: 0.4 MPa
		-X2105	Max. display pressure: 0.2 MPa

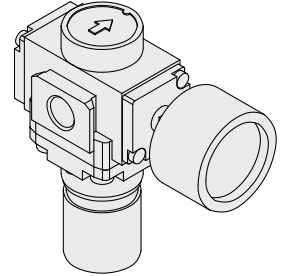

*1 The pressure gauge port is 1/8. The pressure gauge is included in the package, but not assembled.

*2 This product is for overseas use only according to the New Measurement Act.
(The SI unit type is provided for use in Japan.)

For details, refer to the **Web Catalog**.

■ 2-port solenoid valve

VX210 [Z] [Z2A] X276

● Body material/Port size/Orifice diameter

Symbol	Body material	Port size	Orifice diameter
Z	Aluminum	No thread machining (1/8)	ø4
B *1		Rc1/4	
D *1		G1/4	

*1 Produced upon receipt of order

● Specifications

Symbol	Specifications
X276	With restrictor

● Voltage/Electrical entry

Symbol	Voltage	Electrical entry
Z2A	24 VDC	DIN terminal with light (With surge voltage suppressor)
Z2B *2	100 VAC	
Z2C *2	110 VAC	

*2 Produced upon receipt of order
When 100 VAC and 110 VAC are selected, the product without thread machining (symbol: Z) cannot be selected.

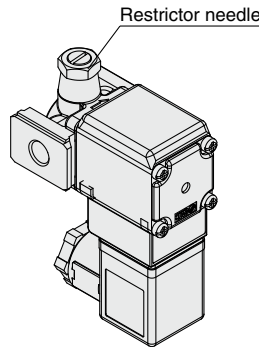

For specifications other than X276, refer to the **Web Catalog**.

■ Bracket (when control unit fitted)
ISA-17

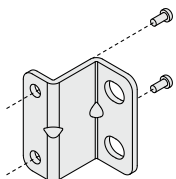

With 2 tapping screws (3 x 8)

■ Spacer with bracket
Y200T-A

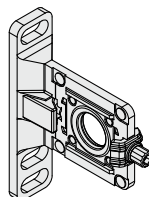

■ Modular adapter
E210-U01

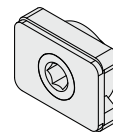

■ Spacer
ISA-18



With O-ring

* When a 2-port solenoid valve is connected to the right

ISA3 Series

Dimensions

ISA3-□□ (Bracket mounting)

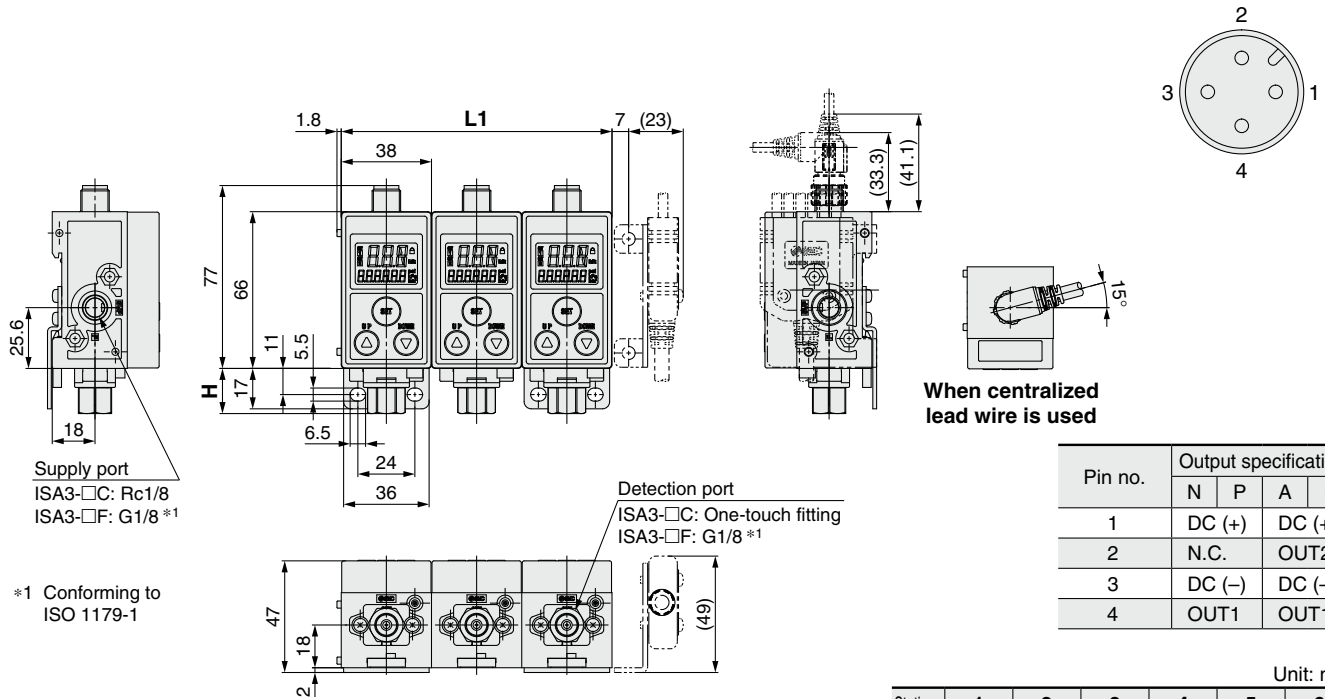

Pin no.	Output specification			
	N	P	A	B
1	DC (+)		DC (+)	
2	N.C.		OUT2	
3	DC (-)		DC (-)	
4	OUT1		OUT1	

Stations	Unit: mm					
	1	2	3	4	5	6
L1	38	76	114	152	190	228
Piping type	C (ø4 One-touch fitting)		C (ø6 One-touch fitting)		F (G thread)	
H	13		13.6		19	

ISA3-□□ (DIN rail mounting)

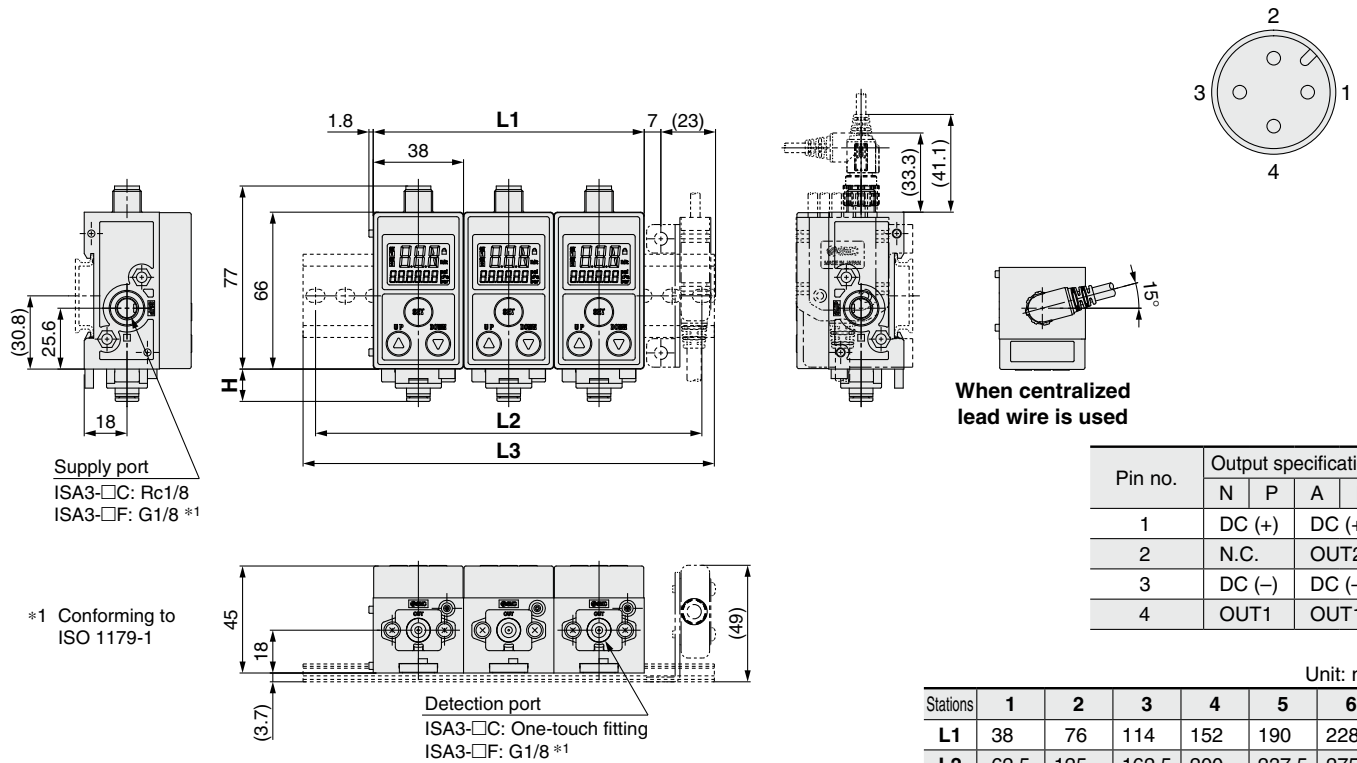

Pin no.	Output specification			
	N	P	A	B
1	DC (+)		DC (+)	
2	N.C.		OUT2	
3	DC (-)		DC (-)	
4	OUT1		OUT1	

Stations	Unit: mm					
	1	2	3	4	5	6
L1	38	76	114	152	190	228
L2	62.5	125	162.5	200	237.5	275
L3	73	135.5	173	210.5	248	285.5
Piping type	C (ø4 One-touch fitting)		C (ø6 One-touch fitting)		F (G thread)	
H	13		13.6		19	

Dimensions

ISA3-□□□-□□□B-L (With control unit)

● Regulator

Round type pressure gauge

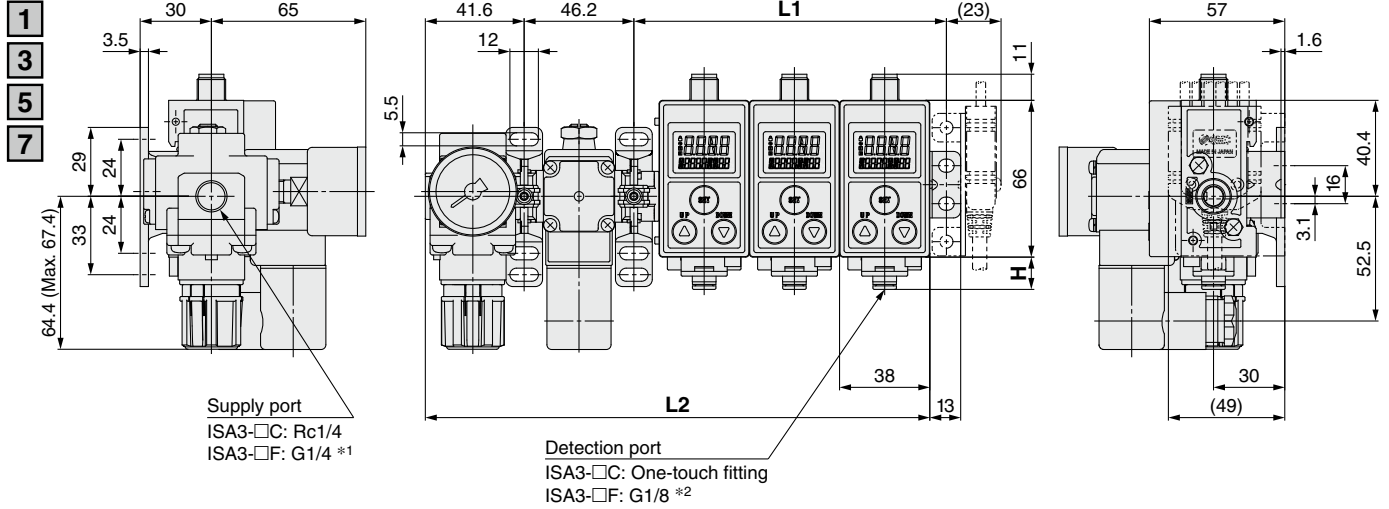

ISA3-□□□-□□□B-L

● Regulator

Without pressure gauge

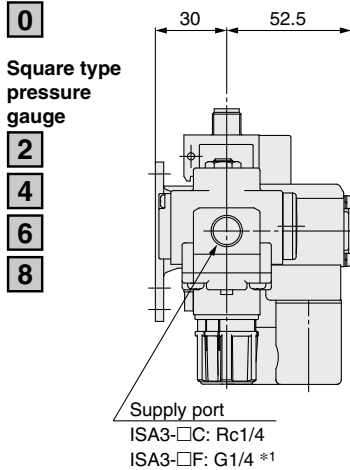

Square type pressure gauge

- 2
- 4
- 6
- 8

ISA3-□□□-□□□B-R

● Regulator

Round type pressure gauge

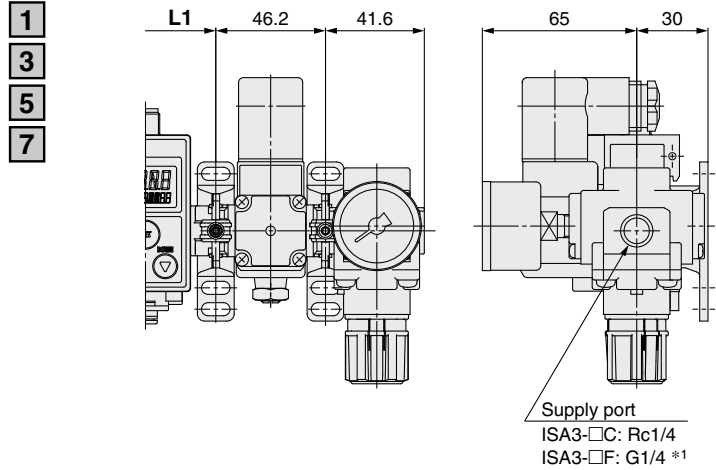

ISA3-□□□-□□□B-R

● Regulator

Without pressure gauge

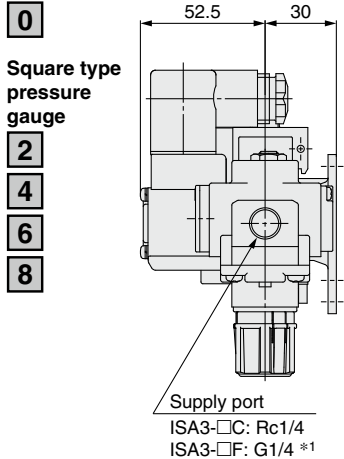

Square type pressure gauge

- 2
- 4
- 6
- 8

Unit: mm

Stations	1	2	3	4	5	6
L1	55.6	93.6	131.6	169.6	207.6	245.6
L2	136.4	174.4	212.4	250.4	288.4	326.4
Piping type	C (ø4 One-touch fitting)		C (ø6 One-touch fitting)		F (G thread)	
H	13		13.6		19	

ISA3 Series

Dimensions

ISA3-□□□-□□□B-LN□

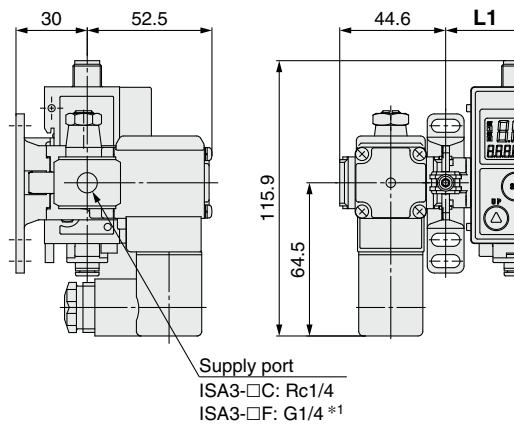

- *1 Conforming to ISO 16030
- *2 Conforming to ISO 1179-1
- * Bracket mounting only

ISA3-□□□-□□□B-RN□

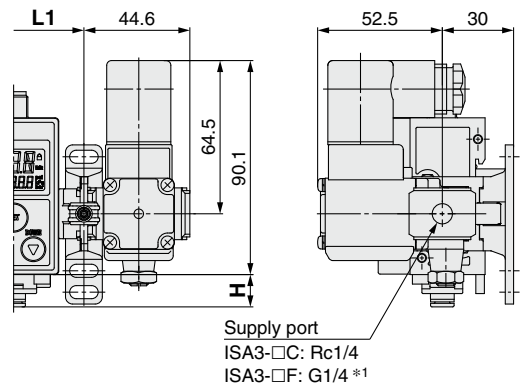

Unit: mm

Stations	1	2	3	4	5	6
L1	55.6	93.6	131.6	169.6	207.6	245.6
Piping type	C (ø4 One-touch fitting)		C (ø6 One-touch fitting)		F (G thread)	
H	13		13.6		19	

ISA3 Series

Dimensions

ZS-31-B (Cable with connector)

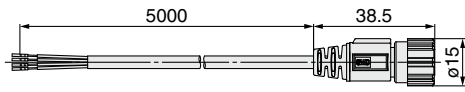

Connector pin no.

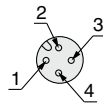

ZS-31-C (Cable with connector)

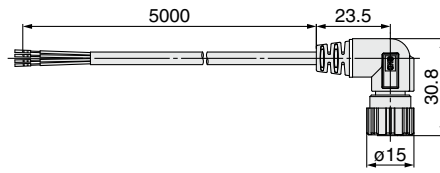

Pin no.	Lead wire color	Description	Pin no.	Lead wire color	Description
1	Brown	DC(+)	3	Blue	DC(-)
2	White	OUT2	4	Black	OUT1

ISA-19/20-□ (Centralized lead wire)

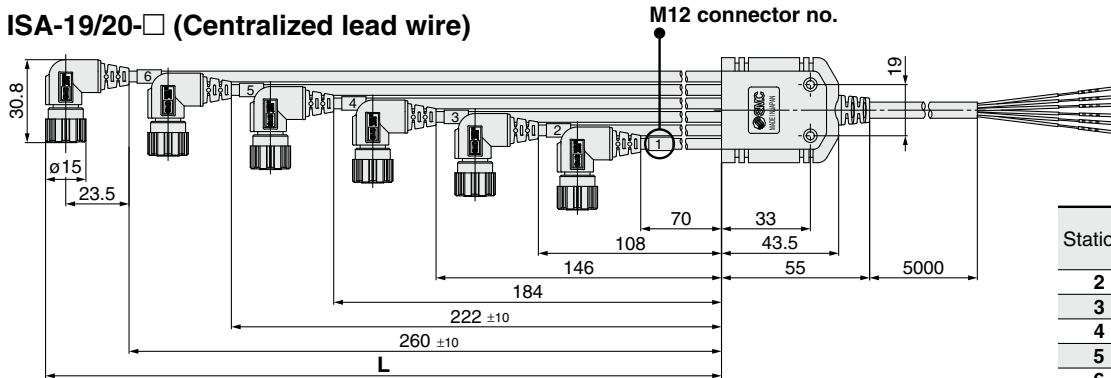

Unit: mm

Stations	Part no.		L
	1 output	2 outputs	
2	ISA-19-2	ISA-21-2	139
3	ISA-19-3	ISA-21-3	177
4	ISA-19-4	ISA-21-4	215
5	ISA-19-5	ISA-21-5	253
6	ISA-19-6	ISA-21-6	291

ISA-19-□ (Centralized lead wire: 1 output type)

M12 connector no.	Pin no.	Description	Lead wire color
1	1	DC(+)	Brown*1
	2	N.C.	—
	3	DC(-)	Blue*1
	4	OUT1	Black
2	1	DC(+)	Brown*1
	2	N.C.	—
	3	DC(-)	Blue*1
	4	OUT1	White
3	1	DC(+)	Brown*1
	2	N.C.	—
	3	DC(-)	Blue*1
	4	OUT1	Gray

M12 connector no.	Pin no.	Description	Lead wire color
4	1	DC(+)	Brown*1
	2	N.C.	—
	3	DC(-)	Blue*1
	4	OUT1	Orange
5	1	DC(+)	Brown*1
	2	N.C.	—
	3	DC(-)	Blue*1
	4	OUT1	Red
6	1	DC(+)	Brown*1
	2	N.C.	—
	3	DC(-)	Blue*1
	4	OUT1	Green

ISA-21-□ (Centralized lead wire: 2 outputs type)

·ISA-21-2/3

M12 connector no.	Pin no.	Description	Lead wire color
1	1	DC(+)	Brown*1
	2	OUT2	Orange
	3	DC(-)	Blue*1
	4	OUT1	Black
2	1	DC(+)	Brown*1
	2	OUT2	Red
	3	DC(-)	Blue*1
	4	OUT1	White
3	1	DC(+)	Brown*1
	2	OUT2	Green
	3	DC(-)	Blue*1
	4	OUT1	Gray

·ISA-21-4/5/6

M12 connector no.	Pin no.	Description	Lead wire color
1	1	DC(+)	Brown*1
	2	OUT2	Yellow
	3	DC(-)	Blue*1
	4	OUT1	Black
2	1	DC(+)	Brown*1
	2	OUT2	Purple
	3	DC(-)	Blue*1
	4	OUT1	White
3	1	DC(+)	Brown*1
	2	OUT2	Gray/Black
	3	DC(-)	Blue*1
	4	OUT1	Gray

M12 connector no.	Pin no.	Description	Lead wire color
4	1	DC(+)	Brown*1
	2	OUT2	Orange/Black
	3	DC(-)	Blue*1
	4	OUT1	Orange
5	1	DC(+)	Brown*1
	2	OUT2	Red/Black
	3	DC(-)	Blue*1
	4	OUT1	Red
6	1	DC(+)	Brown*1
	2	OUT2	Green/Black
	3	DC(-)	Blue*1
	4	OUT1	Green

*1 Brown and blue are connected inside the product.

Error Indication

Main screen	Name	Description	Measures
- - -	Supply pressure error	Displayed when supply pressure is outside the range of 80 kPa to 220 kPa. Measurement is not possible.	Supply rated pressure (100 kPa to 200 kPa). The product will return to measurement mode automatically.
- - -	Outside of the displayable range (Switch point change mode)	The workpiece is outside the displayable range.	Move the workpiece closer to the detection nozzle.
Er 1	OUT1 over current error	The switch output (OUT1) load current has exceeded 80 mA.	Turn the power OFF and remove the cause of the over current. Then turn the power ON again.
Er 3	Zero clear error	Zero clear was not performed at atmospheric pressure. (Pressure outside of ± 14 kPa was supplied present.)	Perform zero clear at atmospheric pressure.
Er 0	System error	An internal data error has occurred.	Turn the power OFF and turn it ON again.
Er 4 to Er 9			
Sub screen	Name	Description	Measures
HHH	Supply pressure error (When [SUP side pressure value display] is set to the sub screen)	Pressure exceeding 220 kPa is supplied.	Keep the supply pressure within the displayable range of -20 kPa to 220 kPa.
LLL		Vacuum pressure (less than -20 kPa) is supplied.	

Relationship Between Supply Pressure and Display

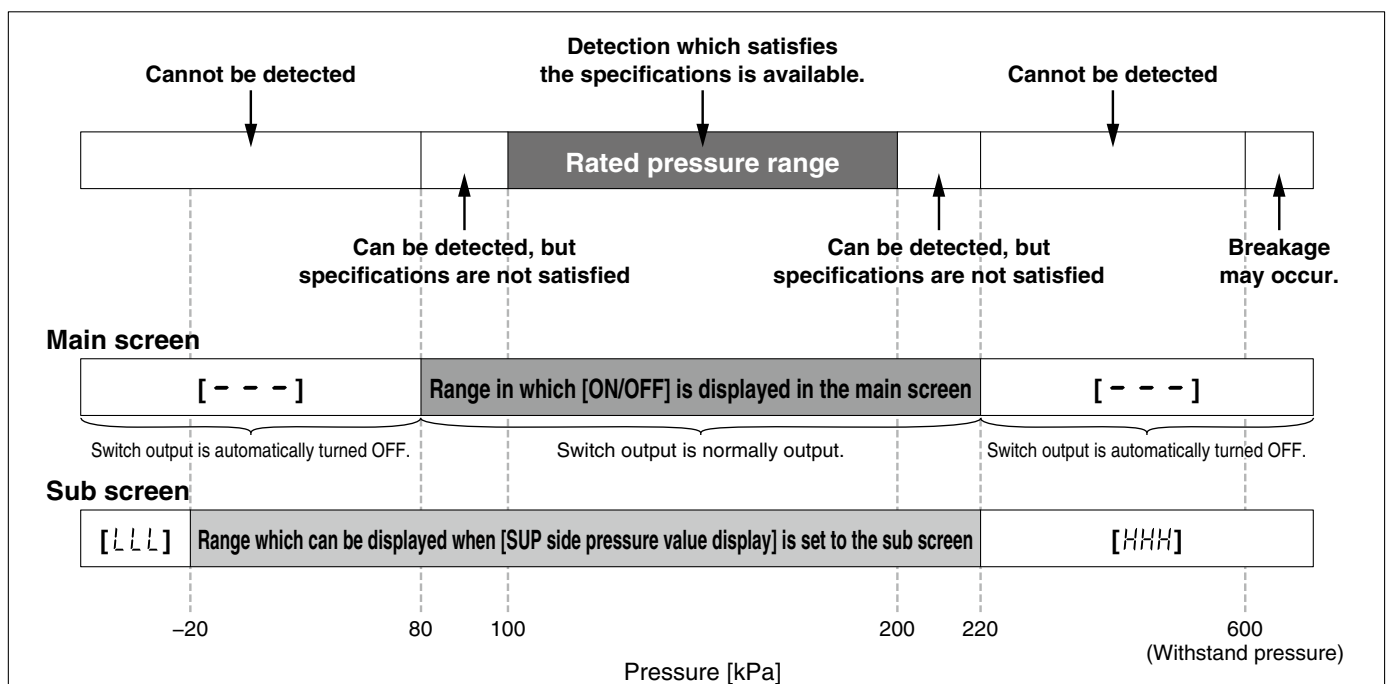

Safety Instructions

These safety instructions are intended to prevent hazardous situations and/or equipment damage. These instructions indicate the level of potential hazard with the labels of “**Caution**,” “**Warning**” or “**Danger**.” They are all important notes for safety and must be followed in addition to International Standards (ISO/IEC)*1), and other safety regulations.

 **Caution:** **Caution** indicates a hazard with a low level of risk which, if not avoided, could result in minor or moderate injury.

 **Warning:** **Warning** indicates a hazard with a medium level of risk which, if not avoided, could result in death or serious injury.

 **Danger :** **Danger** indicates a hazard with a high level of risk which, if not avoided, will result in death or serious injury.

*1) ISO 4414: Pneumatic fluid power – General rules relating to systems.
 ISO 4413: Hydraulic fluid power – General rules relating to systems.
 IEC 60204-1: Safety of machinery – Electrical equipment of machines.
 (Part 1: General requirements)
 ISO 10218-1: Manipulating industrial robots – Safety.
 etc.

Warning

1. The compatibility of the product is the responsibility of the person who designs the equipment or decides its specifications.

Since the product specified here is used under various operating conditions, its compatibility with specific equipment must be decided by the person who designs the equipment or decides its specifications based on necessary analysis and test results. The expected performance and safety assurance of the equipment will be the responsibility of the person who has determined its compatibility with the product. This person should also continuously review all specifications of the product referring to its latest catalog information, with a view to giving due consideration to any possibility of equipment failure when configuring the equipment.

2. Only personnel with appropriate training should operate machinery and equipment.

The product specified here may become unsafe if handled incorrectly. The assembly, operation and maintenance of machines or equipment including our products must be performed by an operator who is appropriately trained and experienced.

3. Do not service or attempt to remove product and machinery/equipment until safety is confirmed.

1. The inspection and maintenance of machinery/equipment should only be performed after measures to prevent falling or runaway of the driven objects have been confirmed.
2. When the product is to be removed, confirm that the safety measures as mentioned above are implemented and the power from any appropriate source is cut, and read and understand the specific product precautions of all relevant products carefully.
3. Before machinery/equipment is restarted, take measures to prevent unexpected operation and malfunction.

4. Contact SMC beforehand and take special consideration of safety measures if the product is to be used in any of the following conditions.

1. Conditions and environments outside of the given specifications, or use outdoors or in a place exposed to direct sunlight.
2. Installation on equipment in conjunction with atomic energy, railways, air navigation, space, shipping, vehicles, military, medical treatment, combustion and recreation, or equipment in contact with food and beverages, emergency stop circuits, clutch and brake circuits in press applications, safety equipment or other applications unsuitable for the standard specifications described in the product catalog.
3. An application which could have negative effects on people, property, or animals requiring special safety analysis.
4. Use in an interlock circuit, which requires the provision of double interlock for possible failure by using a mechanical protective function, and periodical checks to confirm proper operation.

Caution

1. The product is provided for use in manufacturing industries.

The product herein described is basically provided for peaceful use in manufacturing industries.
 If considering using the product in other industries, consult SMC beforehand and exchange specifications or a contract if necessary.
 If anything is unclear, contact your nearest sales branch.

Limited warranty and Disclaimer/ Compliance Requirements

The product used is subject to the following “Limited warranty and Disclaimer” and “Compliance Requirements”.

Read and accept them before using the product.

Limited warranty and Disclaimer

1. The warranty period of the product is 1 year in service or 1.5 years after the product is delivered, whichever is first.*2)
 Also, the product may have specified durability, running distance or replacement parts. Please consult your nearest sales branch.
2. For any failure or damage reported within the warranty period which is clearly our responsibility, a replacement product or necessary parts will be provided. This limited warranty applies only to our product independently, and not to any other damage incurred due to the failure of the product.
3. Prior to using SMC products, please read and understand the warranty terms and disclaimers noted in the specified catalog for the particular products.

*2) Vacuum pads are excluded from this 1 year warranty.

A vacuum pad is a consumable part, so it is warranted for a year after it is delivered. Also, even within the warranty period, the wear of a product due to the use of the vacuum pad or failure due to the deterioration of rubber material are not covered by the limited warranty.

Compliance Requirements

1. The use of SMC products with production equipment for the manufacture of weapons of mass destruction (WMD) or any other weapon is strictly prohibited.
2. The exports of SMC products or technology from one country to another are governed by the relevant security laws and regulations of the countries involved in the transaction. Prior to the shipment of a SMC product to another country, assure that all local rules governing that export are known and followed.

Caution

SMC products are not intended for use as instruments for legal metrology.

Measurement instruments that SMC manufactures or sells have not been qualified by type approval tests relevant to the metrology (measurement) laws of each country. Therefore, SMC products cannot be used for business or certification ordained by the metrology (measurement) laws of each country.

Revision History

Edition B * The F type (Rated distance range: 0.01 to 0.03 mm) has been added. ST

Edition D * A 2 outputs type has been added.

Edition C * A centralized lead wire has been added.
 * The AR-B regulator (control unit) has been added.
 * The AC type 2-port solenoid valve (control unit) has been added.
 * Number of pages has been increased from 16 to 24. US

* The AR-A regulator (control unit) has been deleted.

WW

Safety Instructions

Be sure to read the “Handling Precautions for SMC Products” (M-E03-3) and “Operation Manual” before use.