

4-Port Solenoid Valve Cassette Type Manifold

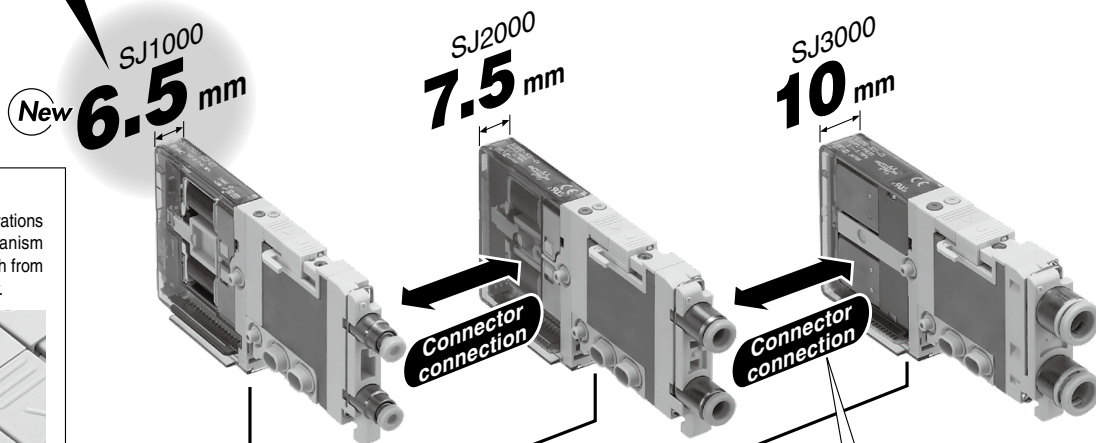

Valve width
A 6.5 mm type has been added.

The SJ3000, SJ2000 and SJ1000 can be mounted together.



Manual locking
Unintentional manual override operations are prevented by a sliding mechanism which covers and prevents the switch from accidentally being pressed manually.

Locked

Unlocked

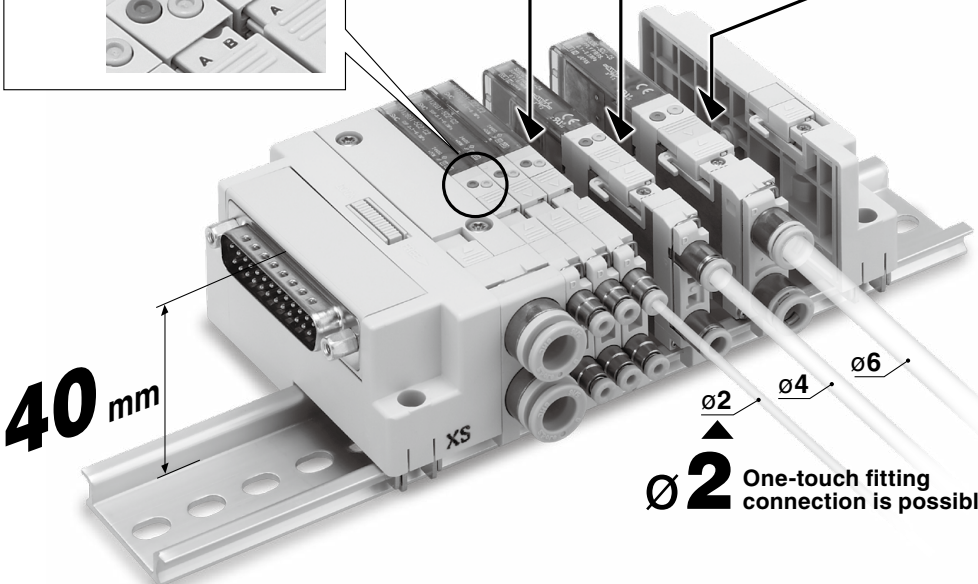

Connector type (Card edge type)

- It is easy to replace valves and increase or decrease the number of stations.
- The 34-pin connector allows for the connection of up to 16 stations with double solenoids, 32 stations with single solenoids.

Card edge connector

Flow Rate Characteristics

Series	C[dm ³ /(s·bar)]	Note
SJ1000	0.32	ø4
SJ2000	0.36	ø4
SJ3000	0.56	ø6

* 4/2 → 3/5 (A/B → E)

D-sub connector

Flat ribbon cable

Mountable serial transmission system

EX180 Integrated Type (For Output)
EX510 Gateway Type

Serial transmission system

SJ1000-X1 Series



SJ1000-X1 Series

Manifold Specifications

Model	D-sub connector	Flat ribbon cable			Serial wiring	
	Type 60F	Type 60P	Type 60PG	Type 60PH	Type 60S□ (EX180)	Type 60S6B (EX510)
Manifold type	Plug-in, Connector type					
1(P: SUP), 3/5(E: EXH)	Common SUP, EXH					
Valve stations	1 to 24 stations		1 to 18 stations	1 to 8 stations	1 to 32 stations	1 to 16 stations
Applicable connector	D-sub connector Compliant with MIL-C-24308 JIS-X-5101	Flat ribbon cable connector Socket: 26-pin MIL type with strain relief Compliant with MIL-C-83503	Flat ribbon cable connector Socket: 20-pin MIL type with strain relief Compliant with MIL-C-83503	Flat ribbon cable connector Socket: 10-pin MIL type with strain relief Compliant with MIL-C-83503	—	—
Internal wiring	Connector type: Positive common, Negative common					
4(A), 2(B) port piping specification	Location	Valve				
	Direction	Horizontal				
Port size	1(P), 3/5(E) port	C6, C8, N7, N9 (Inch size elbow fitting is not available.)				
	4(A), 2(B) port	C2, C4				
Weight W [g]^{*1} (n: Number of SUP/EXH blocks m: Weight of DIN rail)	$W = 51n + m + 133$					

*1 The weight W is the value for the D-sub connector manifold only with internal pilot, SUP/EXH block straight fittings specifications. To obtain the weight with solenoid valves attached, add the solenoid valve weights given on page 2 and **Web Catalog** for the appropriate number of stations. Refer to the **Web Catalog** for the weight of DIN rail. (Please contact SMC for the weight of external pilot specification, elbow fittings.)

* When many valves are operated simultaneously, use B type (SUP/EXH both sides), applying pressure to the 1(P) ports on both sides and exhaust from the 3/5(E) ports on both sides.

Flow Rate Characteristics

Port size		Flow rate characteristics					
1(P) 3/5(E)	4, 2 (A, B)	1 → 2/4 (P → A/B)			4/2 → 3/5 (A/B → E)		
		C[dm ³ /(s·bar)]	b	Cv	C[dm ³ /(s·bar)]	b	Cv
C8	C2	0.12	0.64	0.04	0.13	0.59	0.04
	C4	0.28	0.35	0.08	0.32	0.33	0.08

* The value is for manifold base with 5 stations and individually operated 2-position type.
Please contact SMC for 3-position type.

Solenoid Valve Specifications

Fluid	Air		
Internal pilot operating pressure range [MPa]	2-position single	0.15 to 0.7	
	2-position double	0.1 to 0.7	
	3-position	0.2 to 0.7	
External pilot operating pressure range [MPa]	Operating pressure range		
	-100 kPa to 0.7		
	Pilot pressure range	2-position single	0.25 to 0.7
		2-position double	
3-position			
Ambient and fluid temperatures [°C]		-10 to 50 (No freezing)	
Max. operating frequency [Hz]	2-position single, double	10	
	3-position	3	
Manual override (Manual operation)		Non-locking push type	
Pilot exhaust method	Internal pilot	Main and pilot valve common exhaust	
	External pilot	Pilot valve individual exhaust	
Lubrication		Not required	
Mounting orientation		Unrestricted	
Impact/Vibration resistance [m/s²]		150/30	
Enclosure		Dustproof	

* Impact resistance: No malfunction occurred when it is tested with a drop tester in the axial direction and at the right angles to the main valve and armature in both energized and de-energized states every once for each condition. (Value in the initial state)

Vibration resistance: No malfunction occurred in one sweep test between 45 and 2000 Hz in the axial direction and at the right angles to the main valve and armature in both energized and de-energized states for each condition. (Value in the initial state)

Response Time

Type of actuation	Response time [ms] (at 0.5 MPa)
2-position single	16 or less
2-position double	10 or less
3-position	34 or less

* JIS B8419: 2010 Based on dynamic performance test (Coil temperature: 20°C, at rated voltage)
JIS B8373: 2015

Solenoid Specifications

Coil rated voltage		24 VDC, 12 VDC
Allowable voltage fluctuation		24 VDC: -5% to +10% 12 VDC: -6% to +10%
Power consumption [W]	With power saving circuit (Continuous duty type)	0.23 [Starting 0.55, Holding 0.23]
Surge voltage suppressor		Diode
Indicator light		LED

Weight

Type of actuation		Port size	Weight [g]
		4(A), 2(B)	
2-position	Single	C2 (ø2 One-touch fitting)	34
	Double		38
3-position	Closed center	C4 (ø4 One-touch fitting)	41
	Exhaust center		
	Pressure center		
2-position	Single	C4 (ø4 One-touch fitting)	36
	Double		40
3-position	Closed center	C4 (ø4 One-touch fitting)	43
	Exhaust center		
	Pressure center		

SJ1000-X1 Series

Dimensions

SUP/EXH block: U side

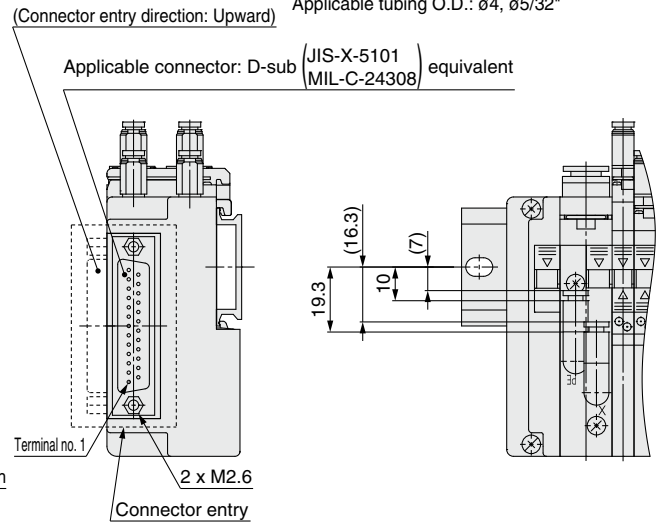
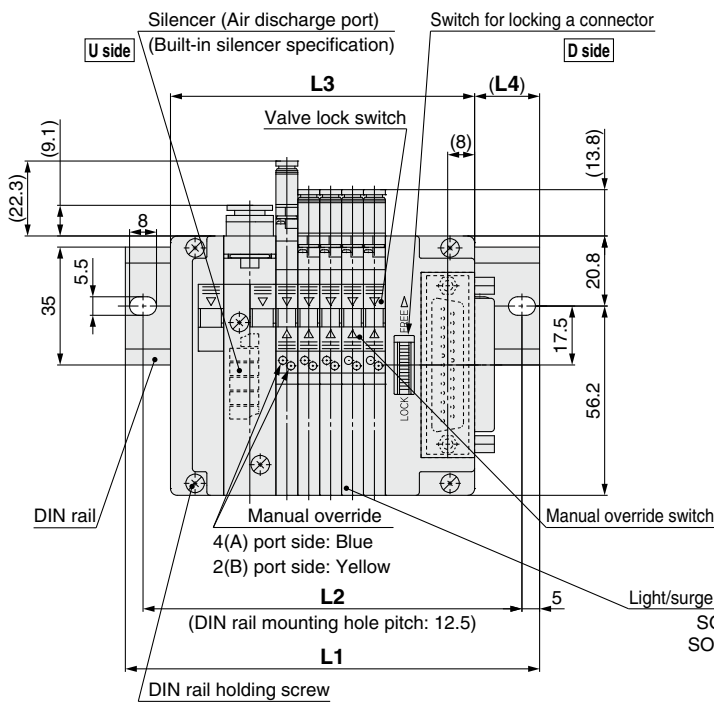
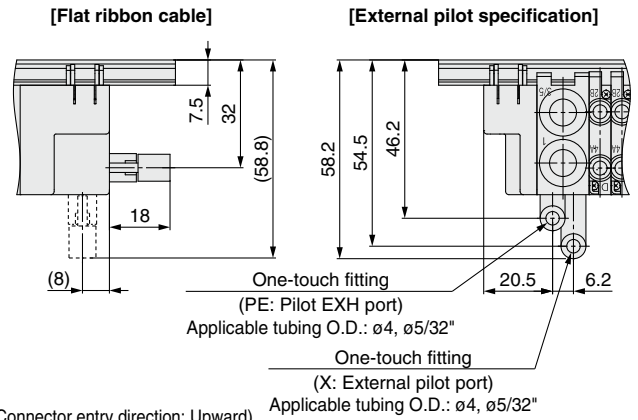
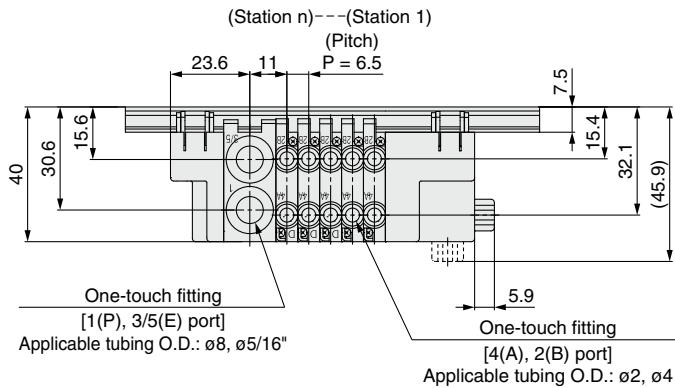

* This drawing shows the D-sub connector.

[Connector entry: Flat ribbon cable]

(Connector entry direction: Upward)

Applicable connector: 26-pin MIL type with strain relief (Compliant with MIL-C-83503)

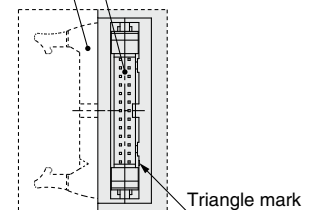

Calculation formula for dimensions

D-sub connector

$L3 = 6.5 \times n1 + 57.8$
 $M = (L3 + 5.9) / 12.5 + 1$ Decimal fractions are truncated.
 $L1 = M \times 12.5 + 23$
 $L2 = L1 - 10.5$
 $L4 = (L1 - L3 + 5.9) / 2$

EX180

$L3 = 6.5 \times n1 + 88.2$
 $M = L3 / 12.5 + 1$ Decimal fractions are truncated.
 $L1 = M \times 12.5 + 23$
 $L2 = L1 - 10.5$
 $L4 = (L1 - L3) / 2$

Flat ribbon cable

$L3 = 6.5 \times n1 + 57.8$
 $M = (L3 + 6.6) / 12.5 + 1$ Decimal fractions are truncated.
 $L1 = M \times 12.5 + 23$
 $L2 = L1 - 10.5$
 $L4 = (L1 - L3 + 6.6) / 2$

EX510

$L3 = 6.5 \times n1 + 105.4$
 $M = L3 / 12.5 + 1$ Decimal fractions are truncated.
 $L1 = M \times 12.5 + 23$
 $L2 = L1 - 10.5$
 $L4 = (L1 - L3) / 2$

n1 = Number of SJ1000

4-Port Solenoid Valve Cassette Type Manifold **SJ1000-X1 Series**

Dimensions

SUP/EXH block: Both sides

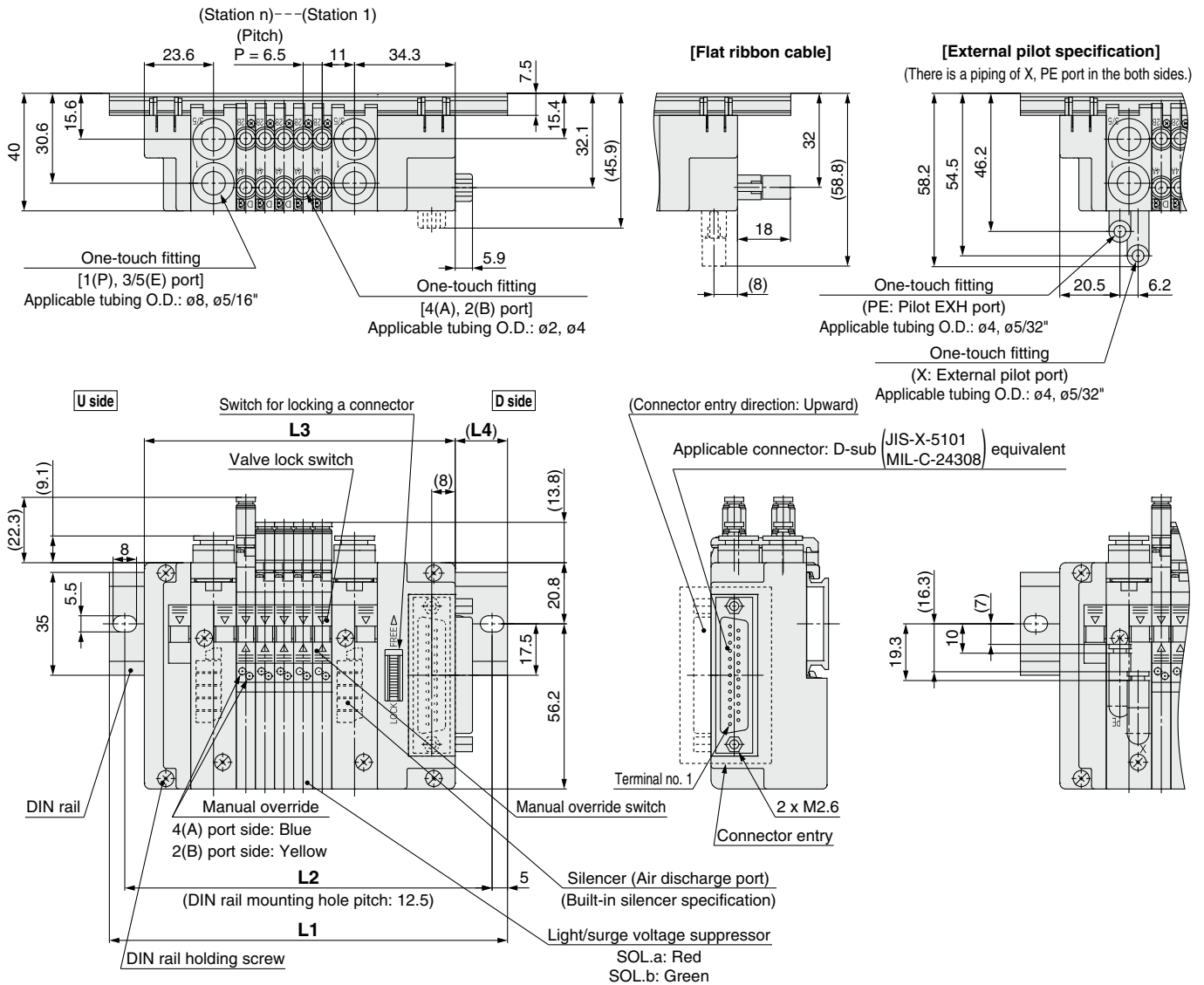

* This drawing shows the D-sub connector.

[Connector entry: Flat ribbon cable]

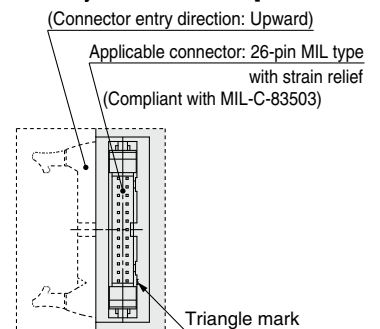

Calculation formula for dimensions

D-sub connector

$$L3 = 6.5 \times n1 + 73.3$$

$$M = (L3 + 5.9) / 12.5 + 1 \text{ Decimal fractions are truncated.}$$

$$L1 = M \times 12.5 + 23$$

$$L2 = L1 - 10.5$$

$$L4 = (L1 - L3 + 5.9) / 2$$

EX180

$$L3 = 6.5 \times n1 + 103.7$$

$$M = L3 / 12.5 + 1 \text{ Decimal fractions are truncated.}$$

$$L1 = M \times 12.5 + 23$$

$$L2 = L1 - 10.5$$

$$L4 = (L1 - L3) / 2$$

Flat ribbon cable

$$L3 = 6.5 \times n1 + 73.3$$

$$M = (L3 + 6.6) / 12.5 + 1 \text{ Decimal fractions are truncated.}$$

$$L1 = M \times 12.5 + 23$$

$$L2 = L1 - 10.5$$

$$L4 = (L1 - L3 + 6.6) / 2$$

EX510

$$L3 = 6.5 \times n1 + 120.9$$

$$M = L3 / 12.5 + 1 \text{ Decimal fractions are truncated.}$$

$$L1 = M \times 12.5 + 23$$

$$L2 = L1 - 10.5$$

$$L4 = (L1 - L3) / 2$$

n1 = Number of SJ1000

SJ1000-X1 Series

Dimensions: SJ1000/2000/3000 Mixed Manifold

SUP/EXH block: U side

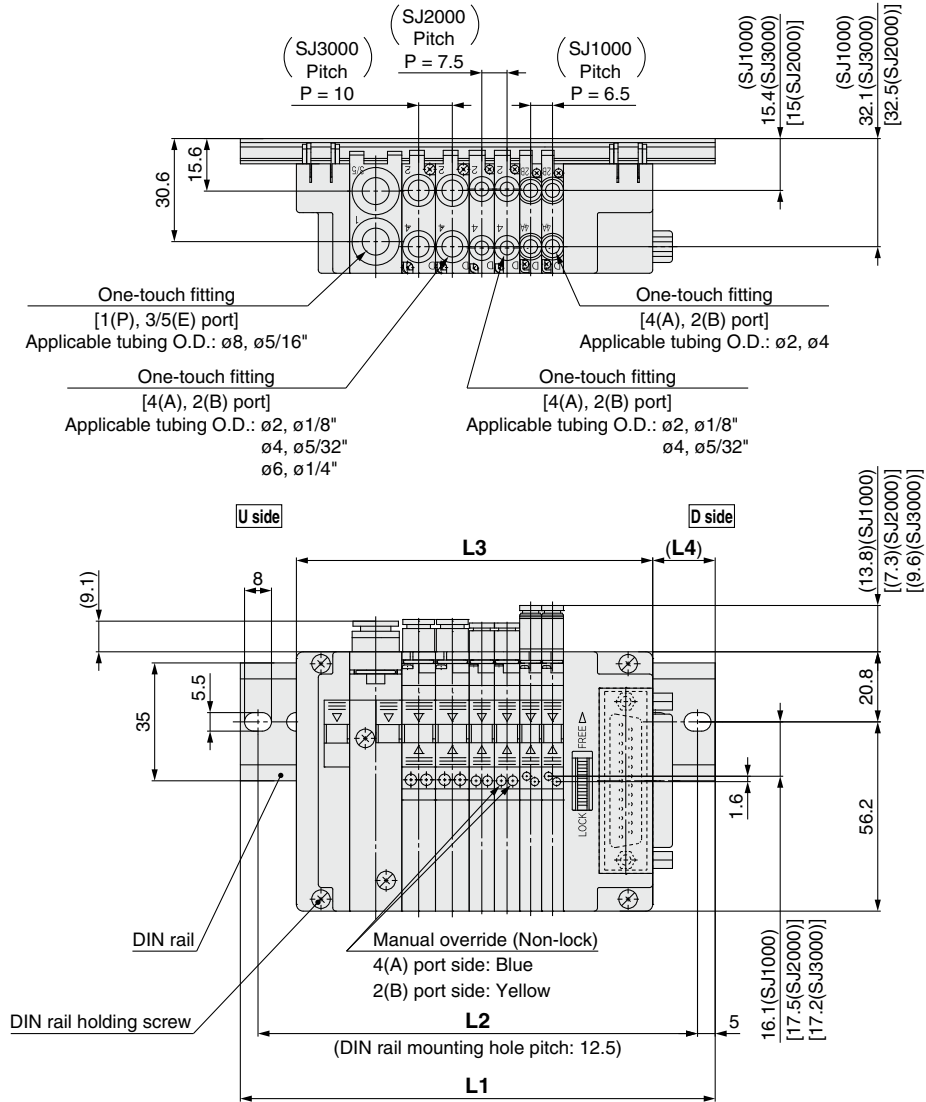

Calculation formula for dimensions

D-sub connector

$$L3 = 6.5 \times n1 + 7.5 \times n2 + 10 \times n3 + 57.8$$

$$M = (L3 + 9.9) / 12.5 + 1 \text{ Decimal fractions are truncated.}$$

$$L1 = M \times 12.5 + 23$$

$$L2 = L1 - 10.5$$

$$L4 = (L1 - L3) / 2 + 1$$

EX180

$$L3 = 6.5 \times n1 + 7.5 \times n2 + 10 \times n3 + 88.2$$

$$M = (L3 + 4) / 12.5 + 1 \text{ Decimal fractions are truncated.}$$

$$L1 = M \times 12.5 + 23$$

$$L2 = L1 - 10.5$$

$$L4 = (L1 - L3) / 2 - 2$$

Flat ribbon cable

$$L3 = 6.5 \times n1 + 7.5 \times n2 + 10 \times n3 + 57.8$$

$$M = (L3 + 10.6) / 12.5 + 1 \text{ Decimal fractions are truncated.}$$

$$L1 = M \times 12.5 + 23$$

$$L2 = L1 - 10.5$$

$$L4 = (L1 - L3) / 2 + 1.3$$

EX510

$$L3 = 6.5 \times n1 + 7.5 \times n2 + 10 \times n3 + 105.4$$

$$M = (L3 + 4) / 12.5 + 1 \text{ Decimal fractions are truncated.}$$

$$L1 = M \times 12.5 + 23$$

$$L2 = L1 - 10.5$$

$$L4 = (L1 - L3) / 2 - 2$$

* The dimensions of L1 to L4 for **SS5J3-M60□D1/2- Stations D** are the same as those of **SS5J3-M60□D1/2- Stations U**.

n1 = Number of SJ1000
n2 = Number of SJ2000
n3 = Number of SJ3000

4-Port Solenoid Valve Cassette Type Manifold **SJ1000-X1 Series**

Dimensions: SJ1000/2000/3000 Mixed Manifold

SUP/EXH block: Both sides

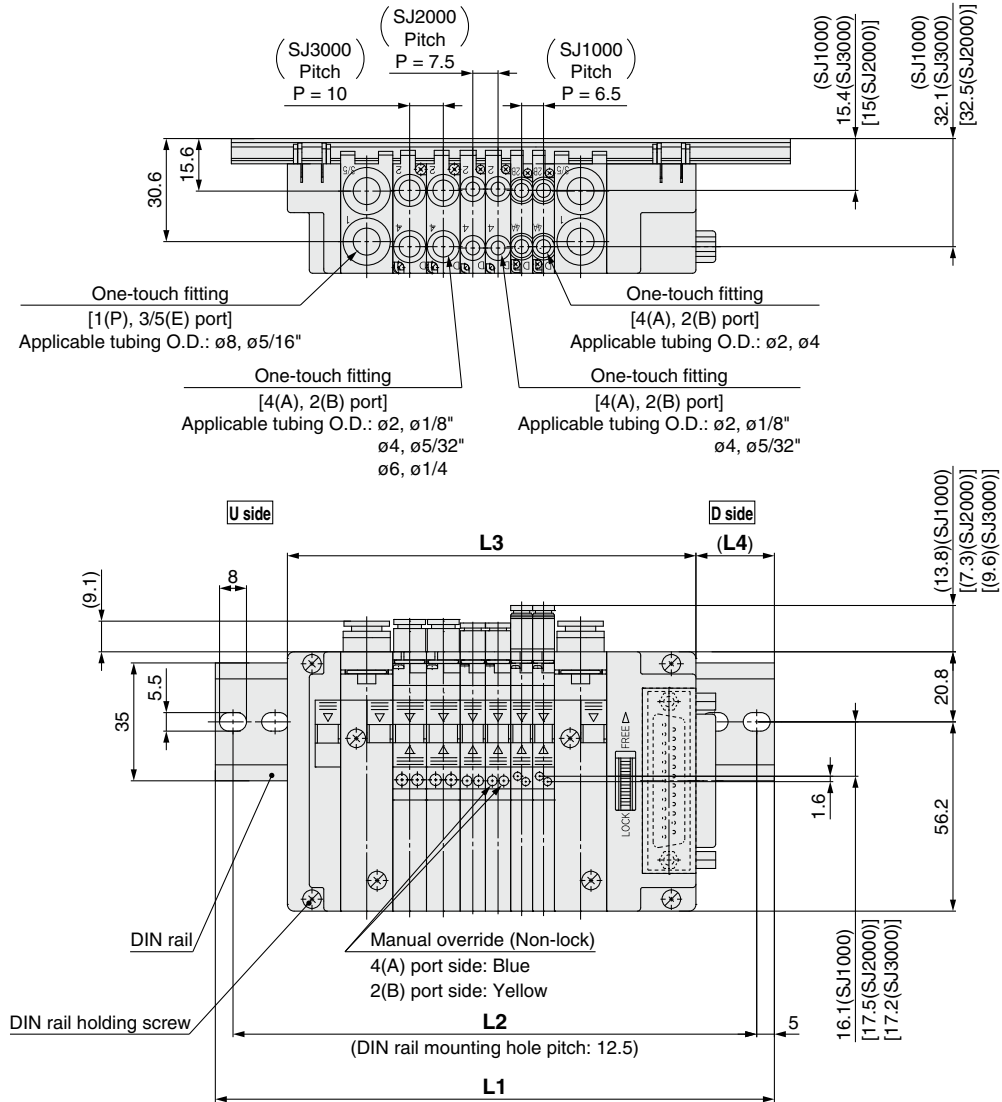

Calculation formula for dimensions

D-sub connector

$$L3 = 6.5 \times n1 + 7.5 \times n2 + 10 \times n3 + 73.3$$

$$M = (L3 + 9.9) / 12.5 + 1 \text{ Decimal fractions are truncated.}$$

$$L1 = M \times 12.5 + 23$$

$$L2 = L1 - 10.5$$

$$L4 = (L1 - L3) / 2 + 1$$

EX180

$$L3 = 6.5 \times n1 + 7.5 \times n2 + 10 \times n3 + 103.7$$

$$M = (L3 + 4) / 12.5 + 1 \text{ Decimal fractions are truncated.}$$

$$L1 = M \times 12.5 + 23$$

$$L2 = L1 - 10.5$$

$$L4 = (L1 - L3) / 2 - 2$$

Flat ribbon cable

$$L3 = 6.5 \times n1 + 7.5 \times n2 + 10 \times n3 + 73.3$$

$$M = (L3 + 10.6) / 12.5 + 1 \text{ Decimal fractions are truncated.}$$

$$L1 = M \times 12.5 + 23$$

$$L2 = L1 - 10.5$$

$$L4 = (L1 - L3) / 2 + 1.3$$

EX510

$$L3 = 6.5 \times n1 + 7.5 \times n2 + 10 \times n3 + 120.9$$

$$M = (L3 + 4) / 12.5 + 1 \text{ Decimal fractions are truncated.}$$

$$L1 = M \times 12.5 + 23$$

$$L2 = L1 - 10.5$$

$$L4 = (L1 - L3) / 2 - 2$$

n1 = Number of SJ1000
n2 = Number of SJ2000
n3 = Number of SJ3000

⚠ Safety Instructions Be sure to read the "Handling Precautions for SMC Products" (M-E03-3) and "Operation Manual" before use.

SMC Corporation

Akihabara UDX 15F,
4-14-1, Sotokanda, Chiyoda-ku, Tokyo 101-0021, JAPAN
Phone: 03-5207-8249 Fax: 03-5298-5362
<https://www.smcworld.com>
© 2019 SMC Corporation All Rights Reserved

Specifications are subject to change without prior notice
and any obligation on the part of the manufacturer.

D-G