

# Series 10-S070

Compact Direct Operated  
3 Port Solenoid Valve

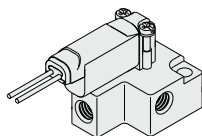

## How to Order Valve



Base mounted

Body ported

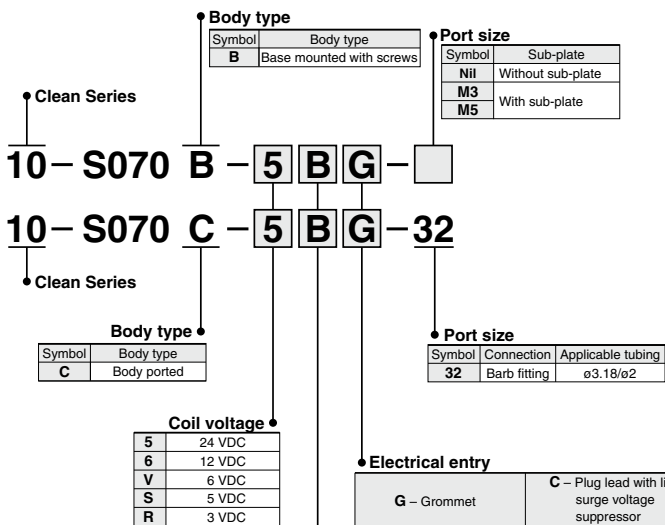
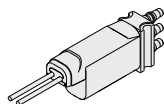

### Power consumption – Pressure specification – Flow rate

Symbol	Power consumption (W)	Maximum operating pressure (MPa)	Cv factor
A	0.35	0.1	0.016
B		0.3	0.011
C	0.5	0.3	0.016
D		0.5	0.011
E (Note)	0.1 (With power saving circuit)	0.1	0.011
F (Note)		0.3	0.006

Note) An option only applicable to 24 VDC plug lead type.



**Made to Order**

(Refer to page 670 for details.)

Symbol	Specifications
X26	Grommet type, Special lead wire length
X50	Universal type
X62	Normally open type

Directional Control Valves

Air Cylinders

Rotary Actuators

Air Grippers

Air Preparation Equipment

Modular F. R.

Pressure Control Equipment

Fittings & Tubing

Flow Control Equipment

Pressure Switches/ Pressure Sensors

## Compact Direct Operated 3 Port Solenoid Valve 10-S070

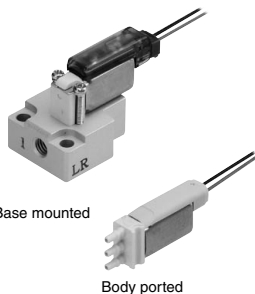

### Symbol

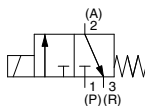

### Specifications

<b>Valve construction</b>	Poppet
<b>Fluid</b>	Air/Low vacuum (1.33 x 10 <sup>2</sup> Pa)
<b>Maximum operating pressure</b>	0.3 MPa (0.35 W, 0.1 W), 0.5 MPa (0.5 W)
<b>Proof pressure</b>	1 MPa
<b>Ambient and fluid temperature</b> <sup>Note 1)</sup>	-10 to 50°C
<b>Lubrication</b>	Not required
<b>Impact/Vibration resistance</b> <sup>Note 2)</sup>	30/150 m/s <sup>2</sup>
<b>Enclosure</b>	IP40
<b>Weight</b>	5 g (Single unit valve)
<b>Mounting orientation</b>	Free

Note 1) Use dry air and prevent condensation at low temperatures.

Note 2) Vibration resistance: No malfunction occurred in a one-sweep test between 45 and 2000 Hz. Test was performed in both energized and de-energized states in the axial direction and at right angles to the armature.

Impact resistance: No malfunction occurred when it was tested with a drop tester in the axial direction and at right angles to the armature in both energized and de-energized states once for each condition.

Note 3) Vacuum can be used within the max. operating pressure differential. Refer to "Vacuum Application" on page 1387 for details.

### Solenoid Specifications

<b>Power consumption</b> <sup>Note 1)</sup>	0.35 W (Standard), 0.5 W (High voltage), 0.1 W (Holding)
<b>Rated coil voltage</b>	3, 5, 6, 12, 24 VDC
<b>Allowable voltage fluctuation</b>	±10% of the rated voltage
<b>Coil insulation type</b>	Equivalent to class B

Note 1) With a light/surge voltage suppressor and power saving circuit, the light consumes a power equivalent to 2 mA.

### Flow Rate Characteristics/Response Time

Power consumption	Maximum operating pressure	Flow rate characteristics			Response time ms <sup>Note 2, 3)</sup>	
		C[dm <sup>3</sup> /(s·bar)]	b	Cv	ON	OFF
0.5 W	0.5 MPa	0.042	0.27	0.011	3 or less	3 or less
	0.3 MPa	0.060	0.28	0.016	5 or less	3 or less
0.35 W	0.3 MPa	0.042	0.27	0.011	3 or less	3 or less
	0.1 MPa	0.060	0.28	0.016	5 or less	3 or less
0.1 W (at holding) with power saving circuit <sup>Note 1)</sup>	0.3 MPa	0.021	0.27	0.006	3 or less	6 or less
	0.1 MPa	0.042	0.28	0.011	5 or less	6 or less

Note 1) 0.35 W at inrush (100 ms) and 0.1 W at holding.

Note 2) The response time is the value at the rated voltage, maximum operating pressure, ambient and fluid temperature (approx. 25°C).

Note 3) If the product is used in the following conditions or environment, switching of the valve may be significantly delayed compared to the above values.

1. The first response time when the valve is not used for a long period of time
2. When using at low supply pressure (0.1 MPa or less)
3. When using in an environment where the ambient and fluid temperature is low (10°C or less)

## Construction

### Component Parts

Number	Description	Material
1	Solenoid coil	—
2	Body	Resin
3	Core	Stainless steel
4	Armature assembly	Stainless steel, resin
5	Return spring	Stainless steel
6	Poppet	FKM
7	Interface gasket	HNBR
8	Mounting screw	Carbon steel
9	Sub-plate	Aluminum

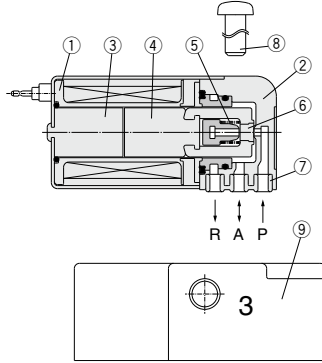

\* The above figure is an example of 10-S070B-□□G base piping type (mounted with screws).

## Replacement Parts

### Plug connector assembly (for plug lead)

**S070-14A-**

● Lead wire length

Nil	150 mm
3	300 mm
6	600 mm
10	1000 mm



### ⑨ Sub-plate

**S070-S-**

● Port size

M3	M3 female thread
M5	M5 female thread

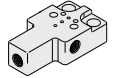

### ⑦ Interface gasket

Valve model	Gasket no.
S070A	S070A-80A-1
S070B	S070B-80A-1
S070M	S070M-80A-1



Note) Order is accepted in 10 units.

### ⑧ Mounting screw

Valve model	Mounting screw no.
S070B	AXT632-106A-1
S070C	AXT632-106A-2



Note) The above part number consists of 10 units.  
Each unit has two screws.  
Order is accepted in 10 units.

### Bracket (S070B)

Valve model	Bracket no.	Note
S070B, SS073B	S070B-80A-2	For sub-plates and manifolds (more than 3 stations)
SS073B	S070B-80A-3	For manifolds (2 stations only)

Note) Order is accepted in 10 units.

\* This is used when mounting a valve on the sub-plate and manifold.

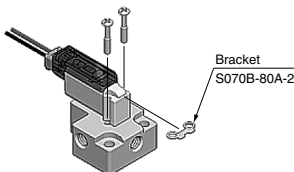

Single unit (base mounted)

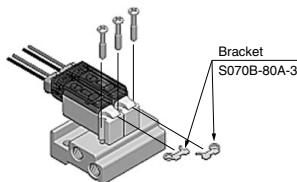

Manifold with 2 stations

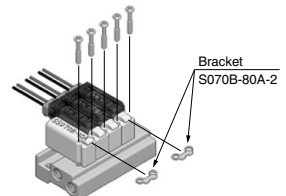

Manifold with more than 3 stations

## Dimensions

Base mounted with screws

**10-S070B-□□G-M3**

Grommet type

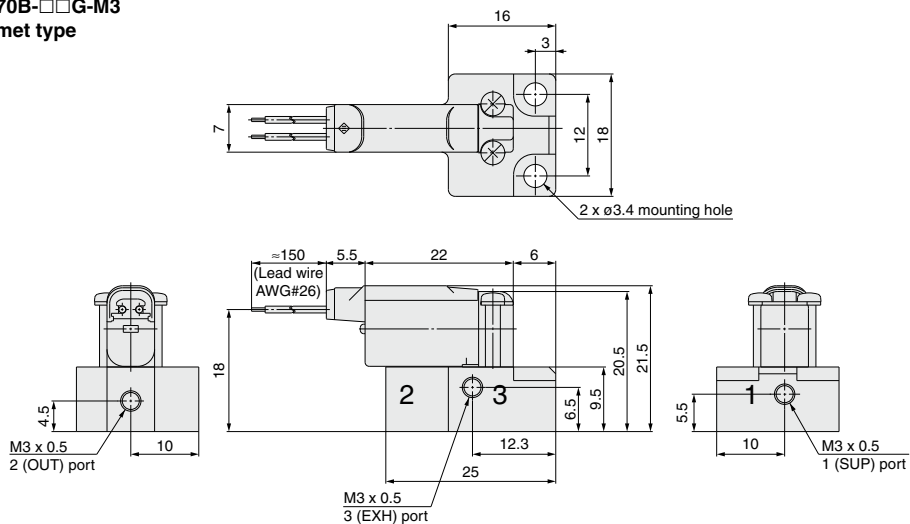

**10-S070B-□□C-M3**

Plug lead type

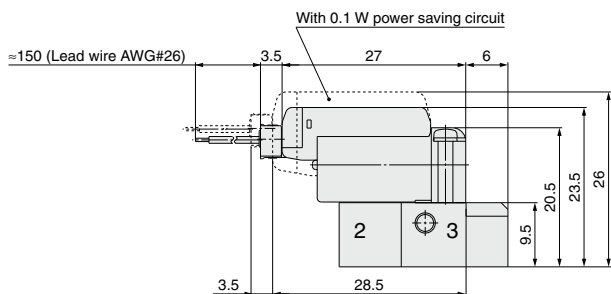

**Dimensions**

Base mounted with screws

10-S070B-□□G-M5  
Grommet type

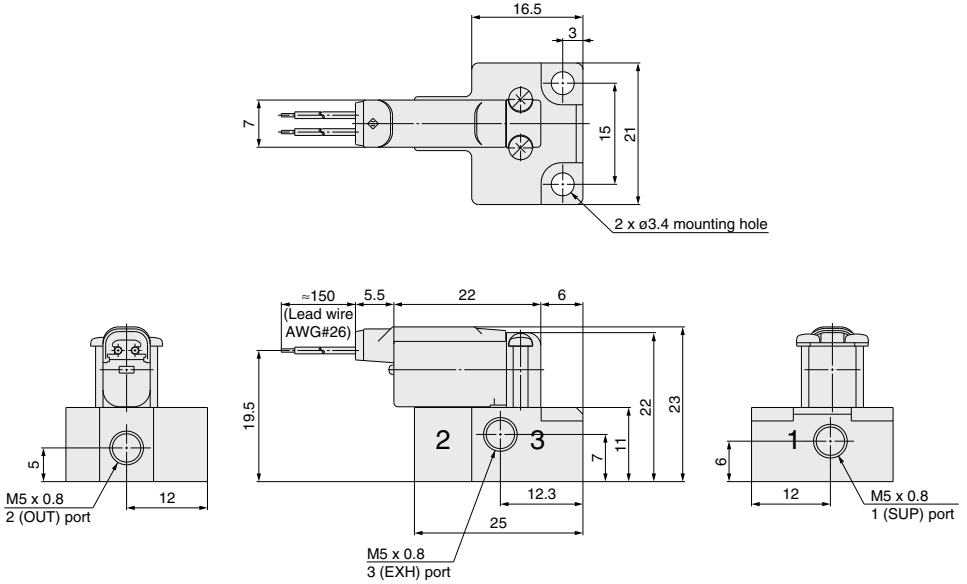

10-S070B-□□C-M5  
Plug lead type

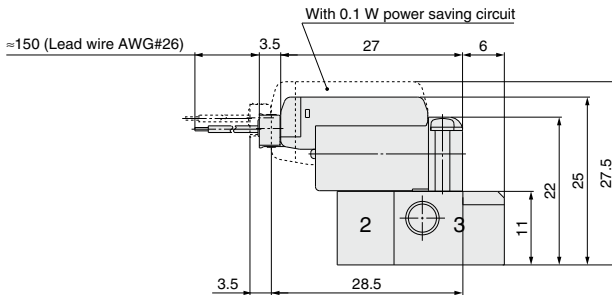

Directional Control Valves

Air Cylinders

Rotary Actuators

Air Grippers

Air Preparation Equipment

Modular F. R.

Pressure Control Equipment

Fittings & Tubing

Flow Control Equipment

Pressure Switches/ Pressure Sensors

## Dimensions

### Body ported

10-S070C-□□G-32

Grommet type

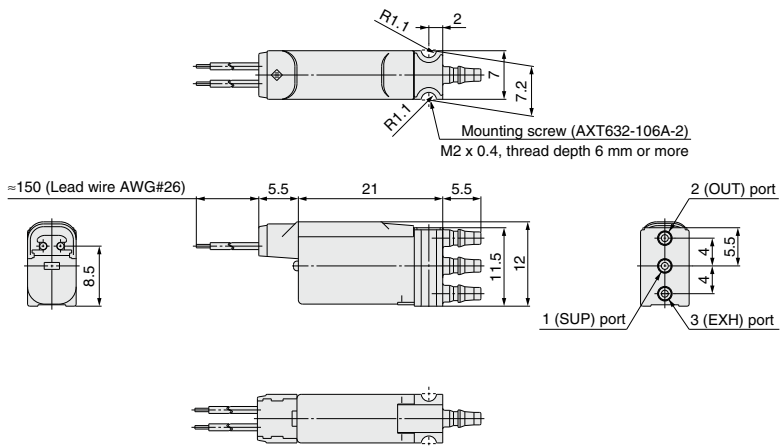

10-S070C-□□C-32

Plug lead type

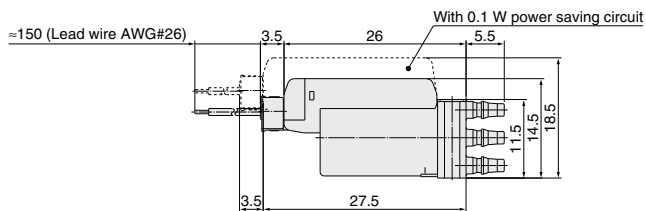

# 3 Port Solenoid Valve

## Series 10-S070/Base Mounted Manifold

### Separable Base Type

#### How to Order Manifold

Base mounted manifold separable base

**10-SS07 3 A01-08 C**

Clean Series

Ports

3 3 port

Port size

Symbol	SUP/EXH port (Applicable tubing)	OUT port	
		Applicable tubing	
A01	Barb fittings (ø6/ø4)	Barb fittings	ø3.18/ø2
A02			ø4/ø2.5
A03			ø2/ø1.2

Note) The outside and inside diameters of the applicable tubing are indicated for the barb fitting.

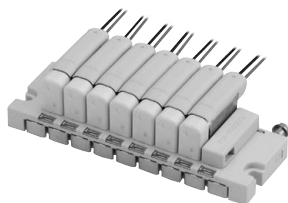

Stations

02	2 stations
03	3 stations
⋮	⋮
20	20 stations

Note) Maximum of 20 stations

Electrical entry

C Grommet/Plug lead

#### How to Order Manifold Assembly

Enter the part numbers of the valves and options to be mounted below the manifold base part number.

<Example>  
**10-SS073A01-04C** ..... 1 set ..... Manifold base no.  
**\*10-S070A-5BG** ..... 3 sets ..... Valve no.  
**\*\*SS070A-10A** ..... 1 set ..... Blanking plate assembly no.

Prefix the symbol "\*" to the solenoid valve part number.

Write sequentially from the 1st station on the D side.

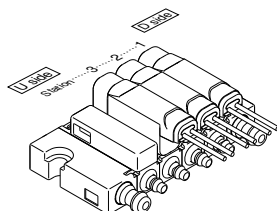

#### How to Order Valve

**10-S070 A-5 B G**

Clean Series

Body type

Symbol	Body type
A	Base mounted with clips

Coil voltage

5	24 VDC
6	12 VDC
V	6 VDC
S	5 VDC
R	3 VDC

Electrical entry

G	Grommet
C	Plug lead with light/surge voltage suppressor
CO	Plug lead without connector and with light/surge voltage suppressor

Power consumption – Pressure specification – Flow rate

Symbol	Power consumption (W)	Maximum operating pressure (MPa)	Cv factor
A	0.35	0.1	0.016
B		0.3	0.011
C	0.5	0.3	0.016
D		0.5	0.011
E (Note)	0.1	0.1	0.011
F (Note)	(With power saving circuit)	0.3	0.006

Note) An option only applicable to 24 VDC plug lead type.

## Dimensions

Base mounted manifold/Separable base

10-SS073A<sup>01</sup>/<sub>02</sub> Stations **C**

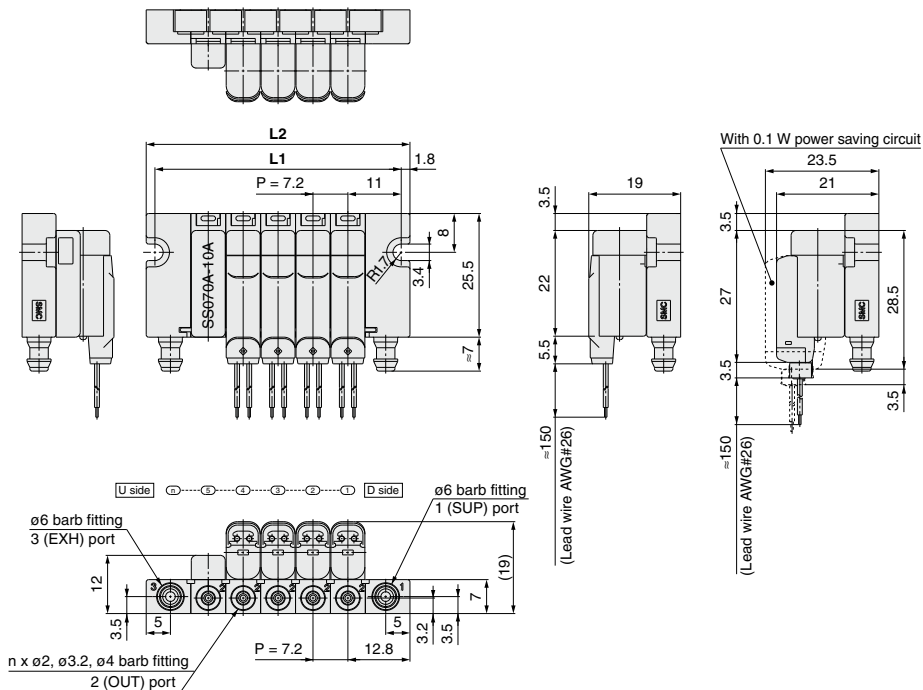

## Dimensions

Formulas:  $L1 = n \times 7.2 + 14.8$ ,  $L2 = n \times 7.2 + 18.4$ , n: Stations (maximum 20 stations)

L \ n	2	3	4	5	6	7	8	9	10	11	12	13	14	15	16	17	18	19	20
L1	29.2	36.4	43.6	50.8	58	65.2	72.4	79.6	86.8	94	101.2	108.4	115.6	122.8	130	137.2	144.4	151.6	158.8
L2	32.8	40	47.2	54.4	61.6	68.8	76	83.2	90.4	97.6	104.8	112	119.2	126.4	133.6	140.8	148	155.2	162.4



# 3 Port Solenoid Valve

## Series 10-S070/Base Mounted Manifold

# Bar Base Specifications

### How to Order Manifold

Base mounted manifold bar base

**10-SS07 3 B01-08 C**

Clean Series

Ports

3 3 port

Port size

Symbol	SUP/EXH port (Applicable tubing)		OUT port (Applicable tubing)	
	Symbol	Port size	Symbol	Port size
B01	M5 female thread	M3 female thread	—	—



Stations

02	2 stations
03	3 stations
⋮	⋮
20	20 stations
(Note) Maximum of 20 stations	

Electrical entry

C Grommet/Plug lead

### How to Order Manifold Assembly

Enter the part numbers of the valves and options to be mounted below the manifold base part number.

<Example>  
**10-SS073B01-04C** ..... 1 set ..... Manifold base no.  
**\*10-S070B-5BG** ..... 3 sets ..... Valve no.  
**\*\*SS070B-10A** ..... 1 set ..... Blanking plate assembly no.

→ Prefix the symbol "\*" to the solenoid valve part number.

Write sequentially from the 1st station on the D side.

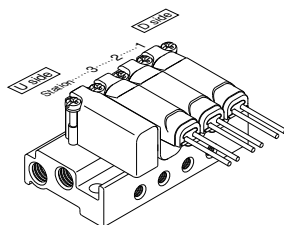

### How to Order Valve

**10-S070 B-5 B G**

Clean Series

Body type

Symbol	Body type
B	Base mounted with screws

Electrical entry

G	Grommet
C	Plug lead with light/surge voltage suppressor
CO	Plug lead without connector and with light/surge voltage suppressor

Coil voltage

5	24 VDC
6	12 VDC
V	6 VDC
S	5 VDC
R	3 VDC

Power consumption – Pressure specification – Flow rate

Symbol	Power consumption (W)	Maximum operating pressure (MPa)	Cv factor
A	0.35	0.1	0.016
B		0.3	0.011
C	0.5	0.3	0.016
D		0.5	0.011
E (Note)		0.1	0.011
F (Note)	(With power saving circuit)	0.3	0.006

(Note) An option only applicable to 24 VDC plug lead type.

## Dimensions

Base mounted manifold/Bar base

10-SS073B01-**Stations**C

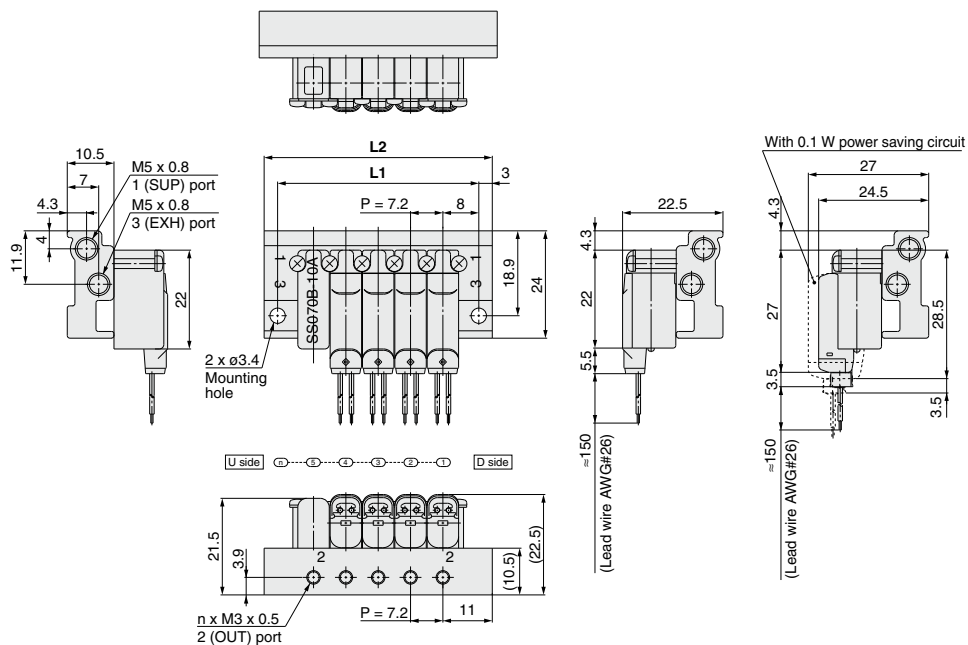

## Dimensions

Formulas:  $L1 = n \times 7.2 + 8.8$ ,  $L2 = n \times 7.2 + 14.8$ , n: Stations (maximum 20 stations)

L	n	2	3	4	5	6	7	8	9	10	11	12	13	14	15	16	17	18	19	20
L1		23.2	30.4	37.6	44.8	52	59.2	66.4	73.6	80.8	88	95.2	102.4	109.6	116.8	124	131.2	138.4	145.6	152.8
L2		29.2	36.4	43.6	50.8	58	65.2	72.4	79.6	86.8	94	101.2	108.4	115.6	122.8	130	137.2	144.4	151.6	158.8

# 3 Port Solenoid Valve

## Series 10-S070/Base Mounted Manifold

### Stacking Type Specifications

#### How to Order Manifold

**Body ported manifold stacking type**

**10-SS07 3 M01-08 C**

Clean Series

Ports

3	3 port
---	--------

Port size

Symbol	SUP/EXH port (Applicable tubing)		OUT port Applicable tubing	
	Barb fittings (ø6/ø4)		Barb fittings	
M01			ø3.18/ø2	
M02			ø4/ø2.5	

Note) The outside and inside diameters of the applicable tubing are indicated for the barb fitting.

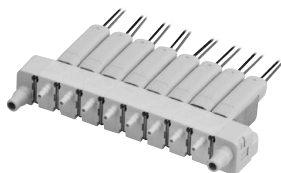

Stations

02	2 stations
03	3 stations
...	...
20	20 stations

Note) Maximum of 20 stations

Electrical entry

C	Grommet/Plug lead
---	-------------------

#### How to Order Manifold Assembly

Enter the part numbers of the valves and options to be mounted below the manifold base part number.

<Example>  
**10-SS073M01-04C** ... 1 set — Manifold base no.  
 \***10-S070M-5BG-32** ... 4 sets — Valve no.

Prefix the symbol "\*" to the solenoid valve part number.

Write sequentially from the 1st station on the D side.

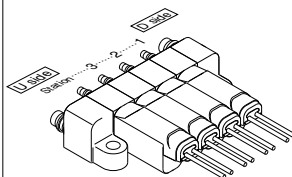

#### How to Order Valve

**10-S070 M-5 B G-32**

Clean Series

Body type

Symbol	Body type
M	Body ported stacking type manifold

Coil voltage

5	24 VDC
6	12 VDC
V	6 VDC
S	5 VDC
R	3 VDC

Port size

Symbol	Connection	Applicable tubing
32	Barb fitting	ø3.18/ø2
40		ø4/ø2.5

Electrical entry

G	Grommet
C	Plug lead with light/surge voltage suppressor
CO	Plug lead without connector and with light/surge voltage suppressor

Power consumption - Pressure specification - Flow rate

Symbol	Power consumption (W)	Maximum operating pressure (MPa)	Cv factor
A	0.35	0.1	0.016
B		0.3	0.011
C		0.3	0.016
D	0.5	0.5	0.011
E Note)		0.1	0.011
F Note)	(With power saving circuit)	0.3	0.006

Note) An option only applicable to 24 VDC plug lead type.

## Dimensions

Body ported stacking type manifold

10-SS073M<sup>01</sup>/<sub>02</sub> - Stations **C**

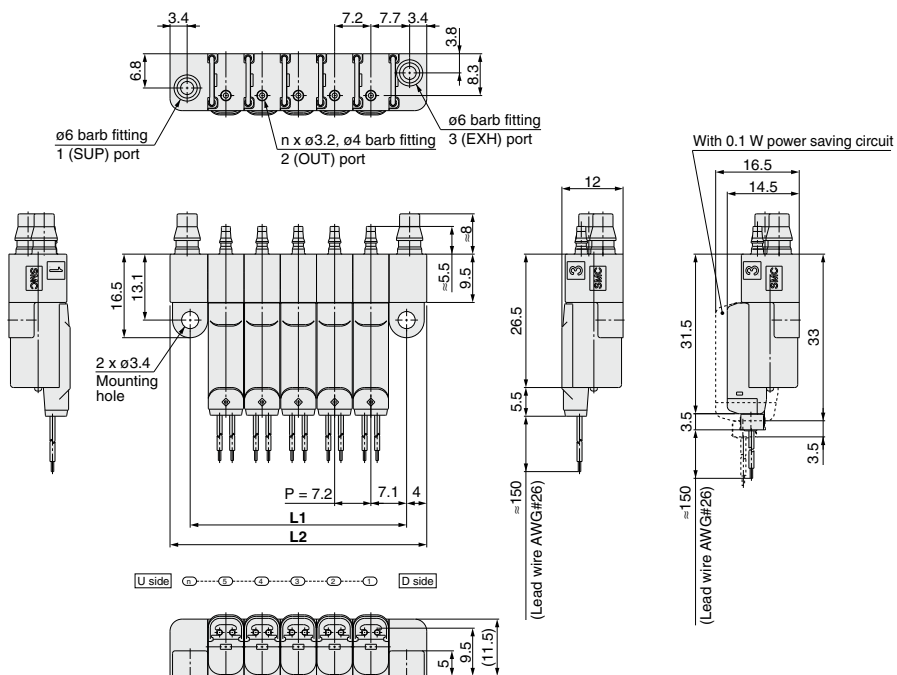

## Dimensions

Formulas:  $L1 = n \times 7.2 + 7$ ,  $L2 = n \times 7.2 + 15$ , n: Stations (maximum 20 stations)

L \ n	2	3	4	5	6	7	8	9	10	11	12	13	14	15	16	17	18	19	20
L1	21.4	28.6	35.8	43	50.2	57.4	64.6	71.8	79	86.2	93.4	100.6	107.8	115	122.2	129.4	136.6	143.8	151
L2	29.4	36.6	43.8	51	58.2	65.4	72.6	79.8	87	94.2	101.4	108.6	115.8	123	130.2	137.4	144.6	151.8	159



## 1 Grommet Type: Special Lead Wire Length

X26

10-S070 [B] - [ ] - [ ] G - [ ] - X26 - [ ]

- Clean Series
- Coil voltage
- Body type
- Grommet type
- Power consumption – Pressure specifications – Flow rate
- Body ported: Port size  
No symbol is used for the base mounted type.
- Lead wire length (L)

Symbol	Length (L)
3	300 mm
6	600 mm
10	1000 mm

Symbol	Body type
A	Base mounted/Clipped
B	Base mounted/Screwed
C	Body ported/Single unit
M	Body ported/Stacking type manifold

## 2 Universal Specifications

X50

10-S070 [B] - [ ] - [ ] G - [ ] - X50

- Clean Series
- Body type
- Coil voltage
- Electrical entry
- Body ported: Port size  
No symbol is used for the base mounted type.
- Power consumption – Pressure specifications – Flow rate

Symbol

Symbol	Power consumption	Max. operating pressure <sup>Note 1)</sup>	Flow rate characteristics		
			C (dm <sup>3</sup> /(s·bar))	b	CV
A	0.35 WDC	0.1 MPa	0.042	0.27	0.011
		0.3 MPa	0.021	0.27	0.006
D	0.5 WDC	0.3 MPa	0.042	0.27	0.011
		0.5 MPa	0.021	0.27	0.006

Note) Vacuum can be used within the max. operating pressure differential.

## 3 Normally Open Specifications

X62

10-S070 [B] - [ ] - [ ] G - [ ] - X62

- Clean Series
- Body type
- Coil voltage
- Electrical entry
- Body ported: Port size  
No symbol is used for the base mounted type.
- Power consumption – Pressure specifications – Flow rate

Symbol

Symbol	Power consumption	Max. operating pressure <sup>Note 2)</sup> (3 port pressure)	Flow rate characteristics		
			C (dm <sup>3</sup> /(s·bar))	b	CV
A	0.35 WDC	0.1 MPa	0.042	0.27	0.011
		0.3 MPa	0.021	0.27	0.006
D	0.5 WDC	0.3 MPa	0.042	0.27	0.011
		0.5 MPa	0.021	0.27	0.006

Note 1) When used in the vacuum release, use 1-port for vacuum, and 3-port for vacuum release pressure.  
Note 2) Vacuum can be used within the max. operating pressure differential.

Directional Control Valves

Air Cylinders

Rotary Actuators

Air Grippers

Air Preparation Equipment

Modular F. R.

Pressure Control Equipment

Fittings & Tubing

Flow Control Equipment

Pressure Switches/Pressure Sensors

## Manifold Options

### Blanking plate assembly (for SS073A)

#### SS070A-10A (for separable base)

This assembly is mounted on a manifold block where the valve is removed for maintenance or a replacement valve is going to be mounted.

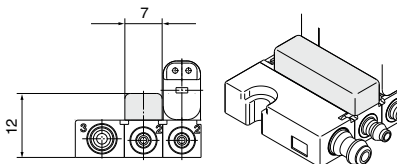

### Blanking plate assembly (for SS073B)

#### SS070B-10A (for bar base)

This assembly is mounted on a manifold block where the valve is removed for maintenance or a replacement valve is going to be mounted.

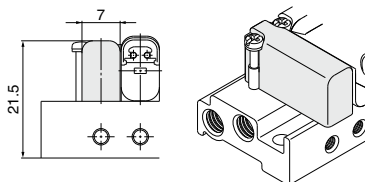

### Intermediate block assembly (for SS073A)

#### SS070A-B (for separable base)

This assembly is used to secure the manifold when a large number of stations are manifolded. (Accommodated as one station.)  
 \* In the manifold specification sheet, specify the position where the block assembly is mounted.

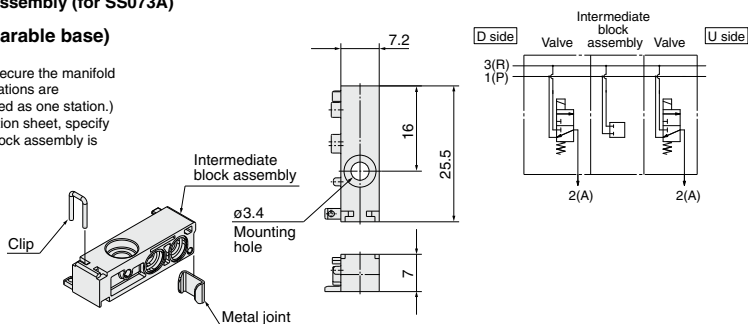

### Intermediate block assembly (for SS073M)

#### SS070M-B (for stacking type)

This assembly is used to secure the manifold when 20 or more stations are manifolded. (Accommodated as one station.)  
 \* In the manifold specification sheet, specify the position where the block assembly is mounted.

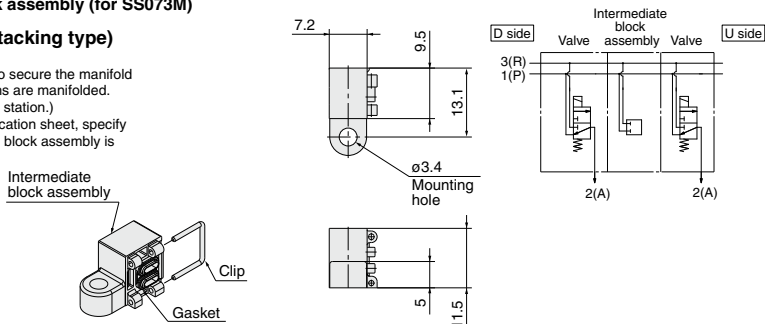

# Series 10-S070

# Exploded View of Stacking Type

Body Ported Type/SS073M01-□C Exploded View of Stacking Type

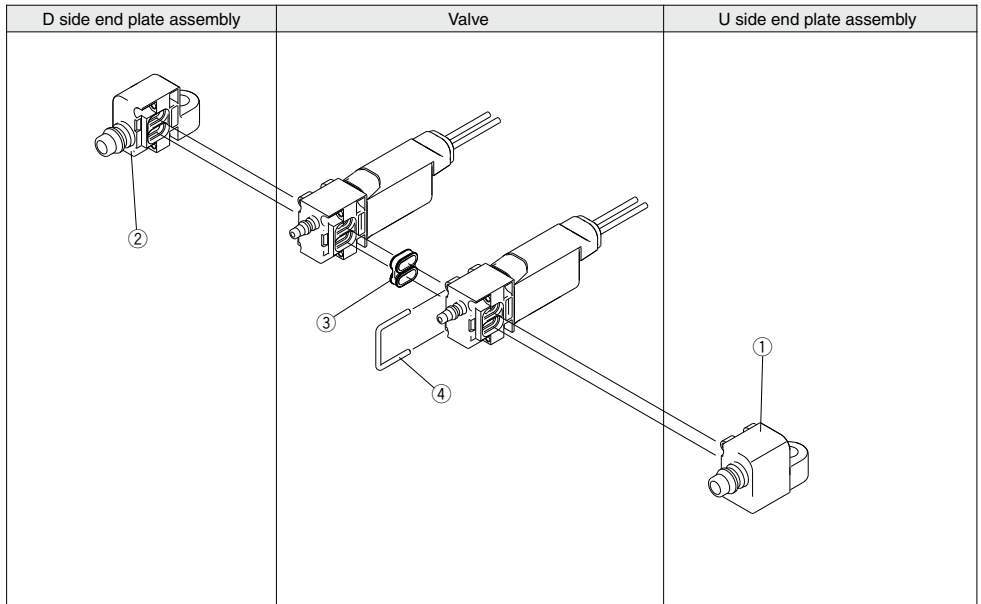

### < U Side End Plate Assembly >

- ① U side end plate assembly no.

**SS070M01-2A**

### < D Side End Plate Assembly >

- ② D side end plate assembly no.

**SS070M01-3A**

### Replacement Parts

No.	Part no.	Description	Material	Qty.
③	S070M-80A-1	Gasket	FKM	10
④	SS070M-80A-2	Clip	Stainless steel	10

Directional  
Control Valves

Air Cylinders

Rotary Actuators

Air Grippers

Air Preparation  
Equipment

Modular F. R.

Pressure Control  
Equipment

Fittings & Tubing

Flow Control  
Equipment

Pressure Switches/  
Pressure Sensors

# Series 10-S070

# Exploded View of Separable Base

Base mounted/SS073A□-□C Exploded View of Separable Base

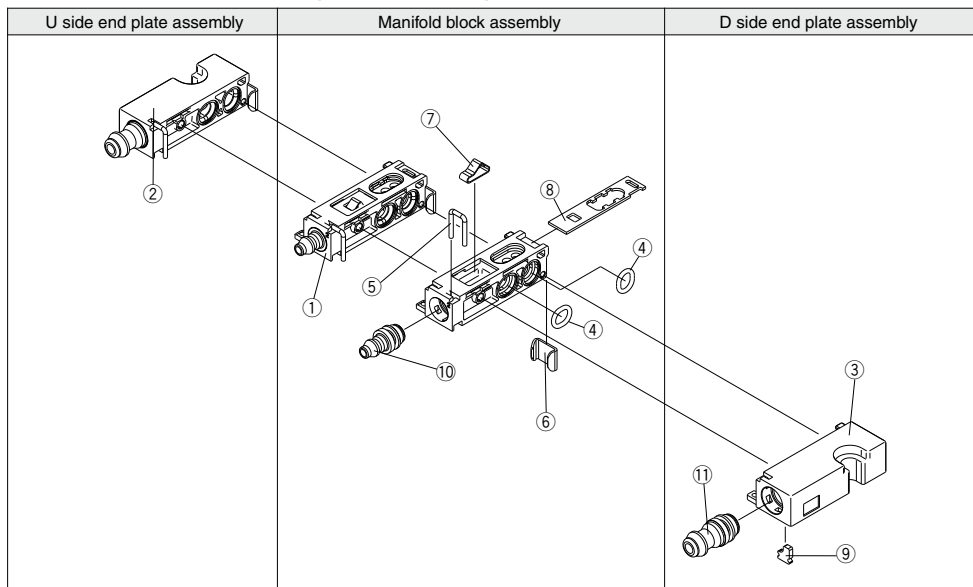

### < Manifold Block Assembly >

① Manifold block assembly no.

**SS070A 01 -1A**

● Port size

01	With ø3.18/ø2 barb fitting
02	With ø4/ø2.5 barb fitting
03	With ø2/ø1.2 barb fitting

### < U Side End Plate Assembly >

② U side end plate assembly no.

**SS070A01-2A**

### < D Side End Plate Assembly >

③ D side end plate assembly no.

**SS070A01-3A**

### < Replacement Parts for Manifold Block >

#### Replacement Parts

No.	Part no.	Description	Material	Qty.
④	SS070A-80A-1	O-ring	FKM	10
⑤	SS070A-80A-2	Clip	Stainless steel	10
⑥	SS070A-80A-3	Metal joint	Stainless steel	10
⑦	SS070A-80A-4	Leaf spring	Stainless steel	10
⑧	SS070A-80A-5	Mounting bracket	Stainless steel	10

### < Replacement Parts for U/D Side End Plate >

#### Replacement Parts

No.	Part no.	Description	Material	Qty.
⑨	SS070A-80A-6	Stopper plate	Stainless steel	10

### < Barb Fitting Assembly >

⑩ Barb fitting assembly (for cylinder port)

**SS070-50A-32**

● Port size

20	Applicable tubing ø2/ø1.2
32	Applicable tubing ø3.18/ø2
40	Applicable tubing ø4/ø2.5

Note) Order is accepted in 10 units.

① Barb fitting assembly (for 1(P), 3(R) ports)

**SS070-51A-60**

● Applicable tubing ø6/ø4

Note) Order is accepted in 10 units.





# Series 10-S070

## Specific Product Precautions 1

Be sure to read this before handling.

Refer to page 1382 for Safety Instructions and pages 677 to 683 for 3/4/5 Port Solenoid Valve Precautions.

### Caution

#### Valve Mounting/Removal

##### 1) Base mounted with screws

With the base mounted type fixed with screws, confirm the installation of the gasket mounted on the body interface and fasten the dedicated mounting screws (AXT632-106-1) at an appropriate torque (0.10 to 0.14 N·m). (Fasten equally so that the valve will not tilt.)

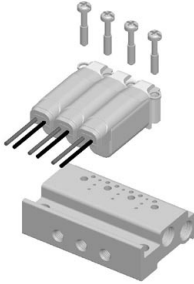

##### 2) Base mounted with clips

① Hook a flat head watchmakers' screwdriver into the hole of the mounting bracket and pull it approximately 1 mm in the direction indicated by the arrow. ② Insert the solenoid valve from above. After confirming that the bottom surface of the solenoid valve contacts the top surface of the manifold, detach the flat head screwdriver from the mounting bracket while holding the solenoid valve body. (Before mounting, confirm the installation of the interface gasket on the solenoid valve body.)

The built-in leaf spring returns the mounting bracket to its original position. (Then confirm that the end of the mounting bracket is aligned with the side of the manifold block. Refer to the figure below.)

Similarly, to remove the valve, pull the mounting bracket and pull up the solenoid valve vertically. Use caution so that no excessive force is applied to the lead wire in mounting and removal.

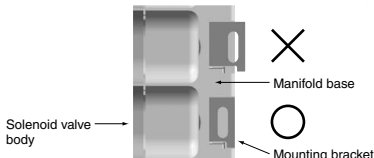
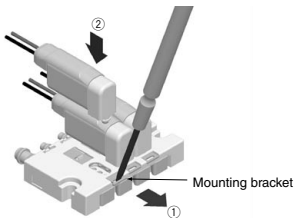

### Caution

#### Screwing in M5/M3 Thread

After tightening by hand, tighten an additional 1/4 turn for M3 and 1/6 turn for M5. Overtightening may cause bending of the thread or air leakage due to deformation of the gasket. Insufficient screwing may cause loosening of the thread or air leakage.

#### Applicable Tubing Size

##### Stacking manifold

Port	Applicable tubing	Recommended tubing
1 (SUP), 3 (EXH)	ø6/ø4	TS0604/TU0604
	ø4/ø2.5	TS0425/TU0425
2 (OUT)	ø3.18/ø2	TIUB01

(Note) In case of a body ported single unit valve, the applicable tubing size is ø3.18/ø2 for all 1 (SUP), 2 (OUT), and 3 (EXH) ports.

If fittings of a brand other than SMC are used, follow the specifications of the fittings to be mounted.

#### Tube Installation (With barb fitting)

- Using tube cutters TK-1, 2, or 3, cut the tubing perpendicularly to the tubing axis while allowing for sufficient margin to the required length.
- Insert the tubing and push it all the way to the barb end. If the tubing is not installed securely to the end, problems such as leakage or disconnection of the tubing can occur.
- When the tubing is inserted into the barb fitting, push it in the direction of the tubing axis to prevent excessive lateral loads being applied to the barb fitting.

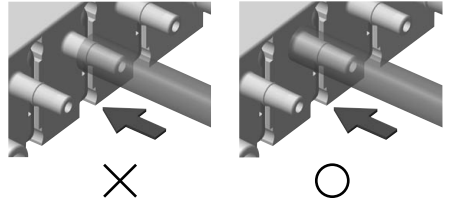

- To remove the tubing from the barb fitting, use caution so that no excessive lateral load will be applied to the barb fitting. When using a cutter to remove the tubing, sufficient care should be taken so as not to make any flaws on the barb fitting.
- After tubing installation, avoid excessive loads, such as tensile, compressive, or bending strength, being applied to the tubing.

Directional Control Valves

Air Cylinders

Rotary Actuators

Air Grippers

Air Preparation Equipment

Modular F. R.

Pressure Control Equipment

Fittings & Tubing

Flow Control Equipment

Pressure Switches/ Pressure Sensors



# Series 10-S070

## Specific Product Precautions 2

Be sure to read this before handling.

Refer to page 1382 for Safety Instructions and pages 677 to 683 for 3/4/5 Port Solenoid Valve Precautions.

### ⚠ Caution Mounting

#### 1) Solenoid valve fixing procedure (body ported single unit)

When mounting a body ported type single unit valve, tighten the dedicated mounting screw (AXT632-106A-2) at an appropriate torque (0.05 to 0.07 N-m) to firmly secure the valve body. (Tighten equally so that the valve will not tilt.) If the coil is fixed, the coil joint may break due to application of an excessive load to the tubing body, for example, when the tubing is inserted. With a base mounted type solenoid valve also, use caution to avoid excessive loads on the coil and lead wire.

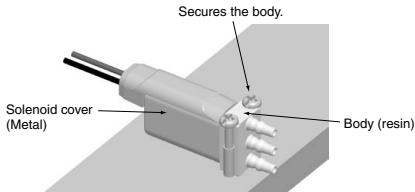

#### 2) 10-SS073M□□-□□C Mounting

There will be slight variations in the width of manifold blocks due to tolerance ( $\pm 0.1$  mm) for the 10-SS073M□□-□□C stacking manifold type. As the manifold is made up of a combination of manifold blocks, there will be an error due to accumulated tolerance between the actual pitch dimensions of the mounting holes used to secure the manifold and the values stated in the catalog. Keep this in mind when increasing the number of stations.

### ⚠ Caution Adding and Removing Manifold Stations

#### 1) Base mounted stacking type

- Remove the clip and metal joint from the position where the new station is to be mounted by pulling them in the directions indicated by the arrows.
- Place the additional manifold block assembly and mount the metal joint and clip by reversing the assembly order. Securely insert the clip and the metal joint so that they will not protrude from the top and bottom surfaces respectively.

The clip is commonly used to secure the manifold block and fittings.

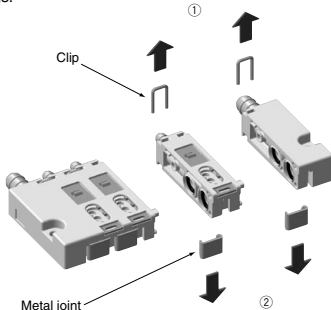

To remove the station, follow the same procedure for assembly and disassembly.

#### 2) Body ported manifold type

- Remove the clip on the position where the station is to be added by pulling it in the direction indicated by the arrow. (Insert a flat head screwdriver in the recess indicated in the figure to remove the clip.)
- Place the additional solenoid valve into the separation and insert the clip. Insert the clip until it fits in the groove on the body side.

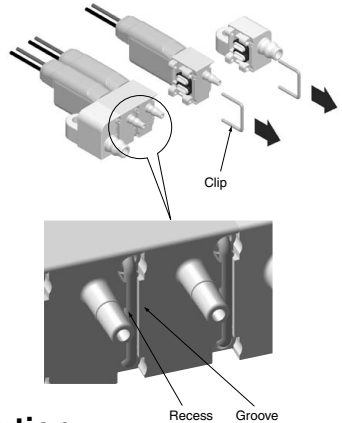

### ⚠ Caution Vacuum Application

An N.C. type valve pressurized at 1 (SUP) port can be used within the maximum operating pressure differential specified for the product. If the valve is to be used in the following applications, however, care should be taken about the piping ports, maximum operating pressure differential and allowable leakage.

#### 1) Vacuum release application

Use 3 (R) port for vacuum pressure and 1 (P) port for vacuum release pressure.

- Set the pressure so that the pressure difference between the 3(R) and 1(P) ports does not exceed the maximum operating pressure of the valve.
- When the 3(R) port is used for the vacuum release (atmospheric pressure to positive pressure) and the 1(P) port is used for the vacuum, use the normally open (N.O.) specifications or the universal specifications.

{ Example } When the vacuum is "−80 kPa" and the vacuum release is "0.1 MPa":  
 $0.1 \text{ MPa} - (-80 \text{ kPa}) = 0.18 \text{ MPa}$   
 A valve with a maximum operating pressure of 0.1 MPa cannot be used.  
 Select a valve with a maximum operating pressure of 0.3 MPa.

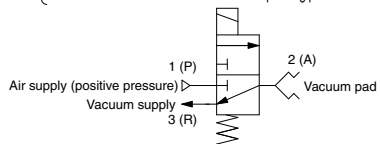

#### 2) Pressure (vacuum) holding application

This valve permits the air leakage. So, take great care since the valve cannot hold the pressure (vacuum) for an extended period of time.



# Series 10-S070

## Specific Product Precautions 3

Be sure to read this before handling.

Refer to page 1382 for Safety Instructions and pages 677 to 683 for 3/4/5 Port Solenoid Valve Precautions.

### Caution Wiring

#### 1) Internal wiring

- Grommet  
(This solenoid valve has no polarity.)



- With light/surge voltage suppressor  
(This solenoid valve has no polarity.)

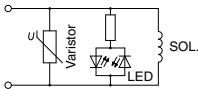

- With 0.1 W power saving circuit

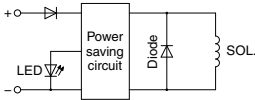

#### 2) Electrical circuit

- (1) Adopt an electrical circuit with no chattering generated at the contact.
- (2) Keep the voltage within the  $\pm 10\%$  range of the rated voltage.  
Care should be taken about the voltage drop when the rated voltage is 6 VDC or less or when the response speed is important.
- (3) When using a C-R element (surge voltage suppressor) for protection of the switching element, please keep in mind that leakage voltage will increase due to leakage current flowing through the C-R element.

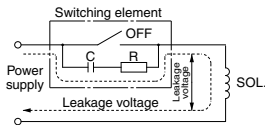

Keep the residual leakage voltage with 2% of the rated voltage.

- (4) Be sure to confirm the applied voltage. If a wrong voltage is applied, it can lead to malfunction or coil burning.
- (5) In wiring, use caution to avoid application of excessive force to the lead wire. It can cause malfunction or break the coil.

### Caution Power Saving Circuit of 0.1 W (At holding)

- 1) The power consumption is 0.35 W at inrush (100 ms) and 0.1 W at holding.

Directional Control Valves

Air Cylinders

Rotary Actuators

Air Grippers

Air Preparation Equipment

Modular F. R.

Pressure Control Equipment

Fittings & Tubing

Flow Control Equipment

Pressure Switches/ Pressure Sensors