



Maintenance Procedure

PRODUCT NAME

Rotary Table

MODEL / Series / Product Number

MSQ Series

MSQB10A	MSQB20A	MSQB30A	MSQB50A
MSQB10R	MSQB20R	MSQB30R	MSQB50R

SMC Corporation



Safety Instructions

These safety instructions are intended to prevent hazardous situations and/or equipment damage. These instructions indicate the level of potential hazard with the labels of "Caution," "Warning" or "Danger." They are all important notes for safety and must be followed in addition to International Standards (ISO/IEC)*1), and other safety regulations.

*1) ISO 4414: Pneumatic fluid power -- General rules relating to systems.

ISO 4413: Hydraulic fluid power -- General rules relating to systems.

IEC 60204-1: Safety of machinery -- Electrical equipment of machines .(Part 1: General requirements)

ISO 10218: Manipulating industrial robots -Safety.

etc.



Caution

Caution indicates a hazard with a low level of risk which, if not avoided, could result in minor or moderate injury.



Warning

Warning indicates a hazard with a medium level of risk which, if not avoided, could result in death or serious injury.



Danger

Danger indicates a hazard with a high level of risk which, if not avoided, will result in death or serious injury.

Warning

1. The compatibility of the product is the responsibility of the person who designs the equipment or decides its specifications.

Since the product specified here is used under various operating conditions, its compatibility with specific equipment must be decided by the person who designs the equipment or decides its specifications based on necessary analysis and test results.

The expected performance and safety assurance of the equipment will be the responsibility of the person who has determined its compatibility with the product.

This person should also continuously review all specifications of the product referring to its latest catalog information, with a view to giving due consideration to any possibility of equipment failure when configuring the equipment.

2. Only personnel with appropriate training should operate machinery and equipment.

The product specified here may become unsafe if handled incorrectly.

The assembly, operation and maintenance of machines or equipment including our products must be performed by an operator who is appropriately trained and experienced.

3. Do not service or attempt to remove product and machinery/equipment until safety is confirmed.

1. The inspection and maintenance of machinery/equipment should only be performed after measures to prevent falling or runaway of the driven objects have been confirmed.

2. When the product is to be removed, confirm that the safety measures as mentioned above are implemented and the power from any appropriate source is cut, and read and understand the specific product precautions of all relevant products carefully.

3. Before machinery/equipment is restarted, take measures to prevent unexpected operation and malfunction.

4. Contact SMC beforehand and take special consideration of safety measures if the product is to be used in any of the following conditions.

1. Conditions and environments outside of the given specifications, or use outdoors or in a place exposed to direct sunlight.

2. Installation on equipment in conjunction with atomic energy, railways, air navigation, space, shipping, vehicles, military, medical treatment, combustion and recreation, or equipment in contact with food and beverages, emergency stop circuits, clutch and brake circuits in press applications, safety equipment or other applications unsuitable for the standard specifications described in the product catalog.

3. An application which could have negative effects on people, property, or animals requiring special safety analysis.

4. Use in an interlock circuit, which requires the provision of double interlock for possible failure by using a mechanical protective function, and periodical checks to confirm proper operation.



Safety Instructions

Caution

The product is provided for use in manufacturing industries.

The product herein described is basically provided for peaceful use in manufacturing industries. If considering using the product in other industries, consult SMC beforehand and exchange specifications or a contract if necessary.
If anything is unclear, contact your nearest sales branch.

Limited warranty and Disclaimer/Compliance Requirements

The product used is subject to the following “Limited warranty and Disclaimer” and “Compliance Requirements”.
Read and accept them before using the product.

Limited warranty and Disclaimer

1. The warranty period of the product is 1 year in service or 1.5 years after the product is delivered, whichever is first.*2)
Also, the product may have specified durability, running distance or replacement parts. Please consult your nearest sales branch.
2. For any failure or damage reported within the warranty period which is clearly our responsibility, a replacement product or necessary parts will be provided.
This limited warranty applies only to our product independently, and not to any other damage incurred due to the failure of the product.
3. Prior to using SMC products, please read and understand the warranty terms and disclaimers noted in the specified catalog for the particular products.
*2) Vacuum pads are excluded from this 1 year warranty.
A vacuum pad is a consumable part, so it is warranted for a year after it is delivered.
Also, even within the warranty period, the wear of a product due to the use of the vacuum pad or failure due to the deterioration of rubber material are not covered by the limited warranty.

Compliance Requirements

1. The use of SMC products with production equipment for the manufacture of weapons of mass destruction(WMD) or any other weapon is strictly prohibited.
2. The exports of SMC products or technology from one country to another are governed by the relevant security laws and regulation of the countries involved in the transaction. Prior to the shipment of a SMC product to another country, assure that all local rules governing that export are known and followed.

Caution

SMC products are not intended for use as instruments for legal metrology.

Measurement instruments that SMC manufactures or sells have not been qualified by type approval tests relevant to the metrology (measurement) laws of each country.
Therefore, SMC products cannot be used for business or certification ordained by the metrology (measurement) laws of each country.

Maintenance Procedure

Rotary Table MSQ Series

Model : MSQB10A MSQB20A MSQB30A MSQB50A
MSQB10R MSQB20R MSQB30R MSQB50R

Rotary tables require periodic maintenance appropriate for the operating conditions to be used in the best condition.

Annual maintenance is desirable in general and replacement of consumable parts such as piston seal is recommended every three years even if there is no problem.

For precautions, refer to the catalogue and operation manual.

Rotary table maintenance procedures are described below.

1. Precautions on Maintenance

- a. Disassemble the product in a open and clean space.
- b. Make sure to protect ports to avoid dust from entering the inside when rotary table is removed.
- c. Be careful not to scar inner sliding sections while disassembling the product.
- d. Contact SMC whenever a question arises in maintenance.

2. Disassembling Procedure

Refer to Figure 1 : disassembly drawing and parts description.

- a. Loosen hexagon socket head cap screws (23) and lift out table (14).
- b. Loosen screws (22) and take out bearing retainer (15).
- c. Push up the bottom of pinion (7) from the bottom side of body (1) and remove deep groove ball bearing (20) and pinion.
- d. Loosen hexagon socket head cap screw (24) and take off end cover (5).
- e. Loosen hexagon socket head cap screw (24) and take off cover (2).
- f. Push out piston (6) from one side as its end face can be seen inside the body.
- g. Take out deep groove ball bearing (19) at the bottom of body.

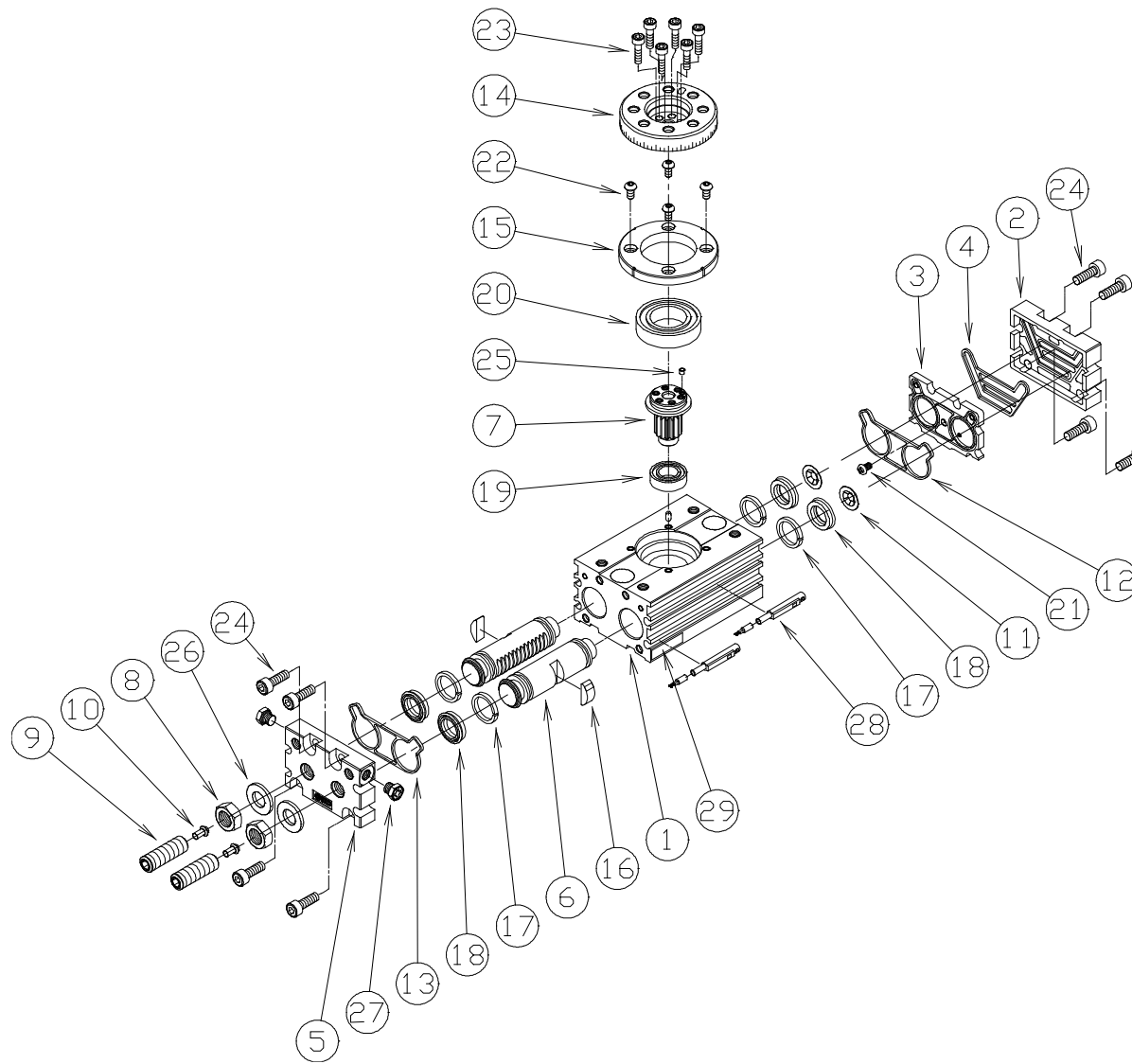

29	Name plate	1	
28	Auto switch	—	
27	Plug	2	
26	Seal washer	2	
25	Parallel pin	1	
24	Hexagon socket head cap screw	8	
23	Hexagon socket head cap screw	6	
22	Hexagon thin socket head cap screw (Size10 Round head philips screw	4	
21	Round head philips screw No.0	1	
20	Deep groove ball bearing	1	
19	Deep groove ball bearing	1	
18	Piston seal	4	
17	Wear ring	4	
16	Magnet	2	
15	Bearing retainer	1	
14	Table	1	
13	Gasket (End cover)	1	
12	Gasket (Cover)	1	
11	Push nut	2	
10	Cushion pad	2	
9	Adjustment bolt (or shock absorber)	2	Not required for models with shock absorber.
8	Compact hexagon nut	2	
7	Pinion	1	
6	Piston	2	
5	End cover	1	
4	Seal	1	
3	Plate	1	
2	Cover	1	
1	Body	1	
No.	Description	Qty.	Note

Fig. 1 Assembly Drawing & Parts Descriptions

3. Spare Parts Replacement Procedure

All the consumable parts such as piston packing are available as a maintenance kit.

The part numbers are shown in Table 1 below.

Table 1 Maintenance Kit Part Number

Model	Maintenance kit part number	Contents
MSQB10 *	P523010-5	Seal (4)
MSQB20 *	P523020-5	Gasket (12)
MSQB30 *	P523030-5	Gasket (13)
MSQB50 *	P523040-5	Wearing (17)
		Piston seal (18)
		Seal washer (26)
		Grease pack

3.1 Seal (4)

- Apply grease to new seal.
- Loosen round head Philips screws No.0 (21) and take off plate (3).
- Remove old seal from cover (2).
- Set new seal into packing groove of cover.
- Check to see whether if seal is positioned in groove properly and put plate back.
- Tighten round head Philips screws No.0 to fix plate.

3.2 Gasket (12) (13)

- Apply grease to new gaskets.
- Take off old gaskets on plate (3) and end cover (5).
- Attach new gaskets.
- Check to see whether if they are set into grooves properly.

3.3 Piston seal (18) & Wear Ring (17)

- Apply grease to new piston seal.
- Remove old piston seal from piston (6).
- Remove old wear rings from piston as opening a cut in each circumference.
- Attach new wear rings by opening a cut severally.
- Set new piston seal : fit a part of piston seal on packing grooves and pull it to the opposite side for setting. Do not use a tool so as not to scratch packing.
Follow the direction shown in Figure 2 for piston seal orientation.
- Check to see whether if piston seal and wear rings are set properly. Give special care for the position of piston seal.

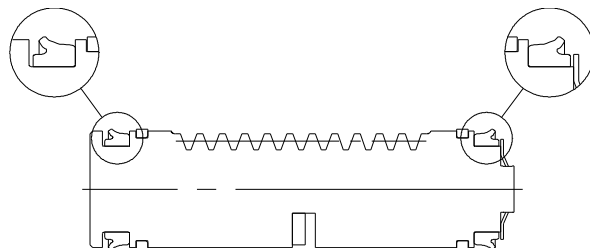

Fig. 2 Piston Seal Orientation

3.4 Seal Washer (26)

- a. Loosen and take off compact hexagon nuts (8) together with adjustment bolts (9) / shock absorbers from end cover (5).
- b. Pull out old seal washers from adjustment bolts / shock absorbers.
- c. Attach new seal washers to adjustment bolts / shock absorbers.
- d. Set adjustment bolts / shock absorbers in end cover and fix them with compact hexagon nuts.

4. Reassembly Procedure

- a. Apply grease to inner cylinder surface of body (1).
- b. Set deep groove ball bearing (19) into body.
- c. Insert pistons (6) in body.

Set Figure 3 for position and direction of pistons. Be careful not to damage piston seal in Section A, Figure 3, while inserting. (Press down piston seal with a round-ended spatula and pass it through Section A.)

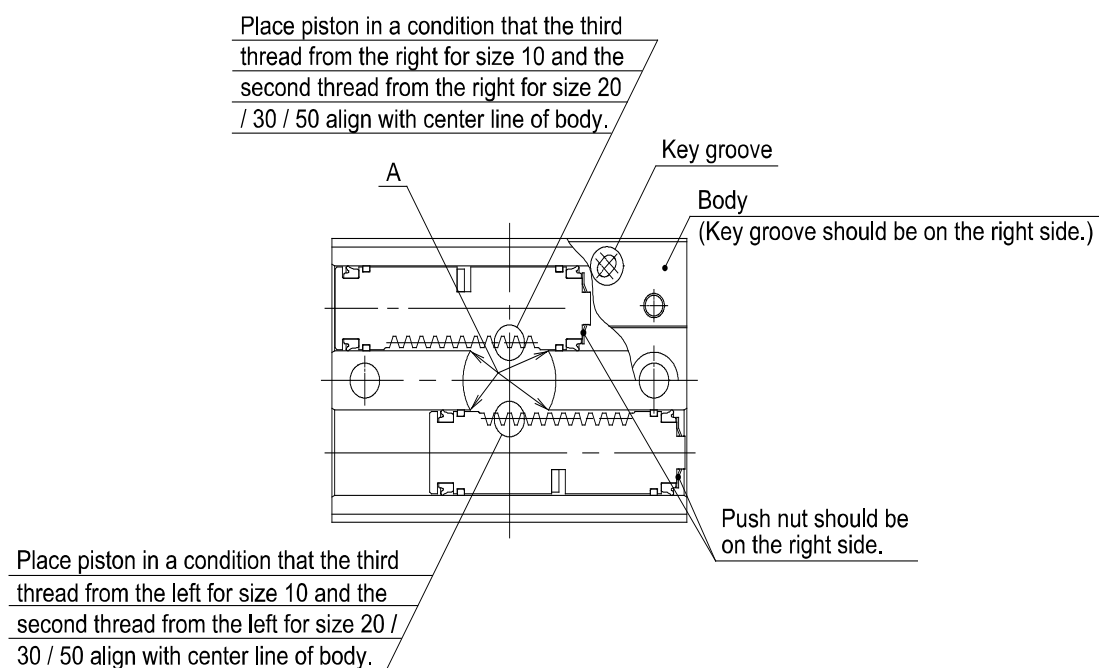
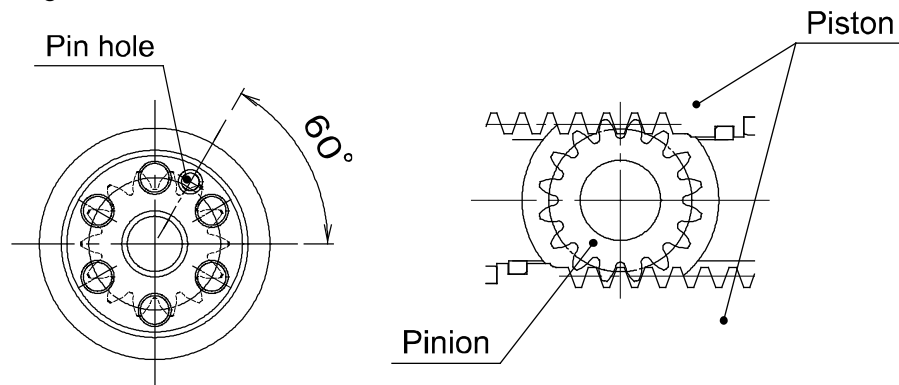

Fig.3 Piston Position & Direction

- d. Insert pinion (7) into body : confirm piston position with Figure 3 and insert pinion as shown in Figure 4.



Assemble the pinion so that the peak of the piston gear engages with the root of the pinion gear on the center line of the body when viewing the pinion from the top, with the pin hole in the position shown in the figure.

Fig. 4 Pinion Position

- e. Attach deep groove ball bearing (20) to body.
- f. Mount bearing retainer in body and fix it with screws (22).
(Tightening torque : Table2—①)
- g. Fix cover (2) with hexagon socket head cap screw (24).
(Tightening torque : Table2—②)
Check to see whether if gasket (12) is set properly into grooves.
Installation position of the cover is shown in Figure 5.
- h. Fix end cover (5) with hexagon socket head cap screw (24).
(Tightening torque : Table2—②)
Check to see whether if gasket (13) is set properly into grooves.
Installation position of the end cover is shown in Figure 5.

- i. Set table (14) on pinion (7) and fix them with hexagon socket head cap screw (23).
 (Tightening torque : Table2—③)
 Fix the table in a condition that pin holes on the top are located as shown in Figure 5 at the end of counter-clockwise turn for 180° of rotation angle.

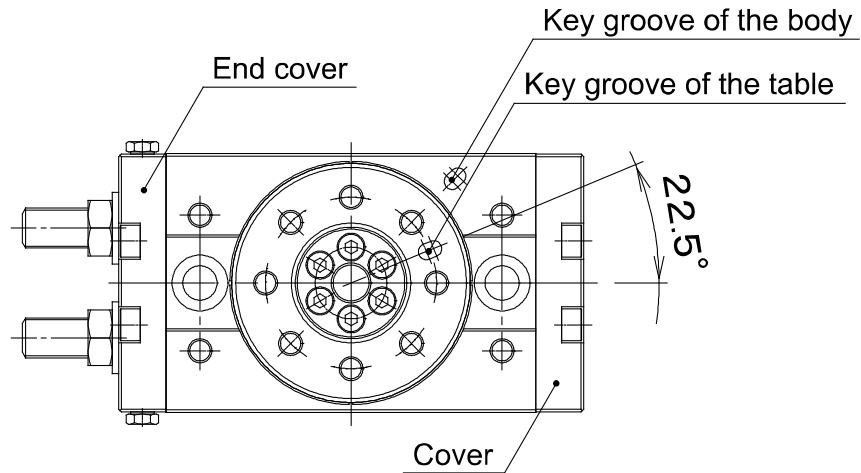

Fig. 5 Assembly position of the cover, end cover and table

- j. Screw down and fix with compact hexagon nut adjustment bolts / shock absorbers to the specified rotation angle. (Tightening torque : Table2—④)
 k. Perform operation test and external leak check when reassembly is completed.

Table2 tightening torque [N·m]

No. \ Size	10	20	30	50
①	0.9 ~ 1.5	4.0 ~ 6.0		5.9 ~ 8.3
②	2.0 ~ 2.5	4.2 ~ 5.2		7.2 ~ 8.3
③	1.1 ~ 3.1	2.9 ~ 4.9	4.9 ~ 6.9	7.4 ~ 9.8
④	1.7	3.1		10.8

Revision history
A: Complete revision due to product review
B: Corrected to the latest format

SMC Corporation

4-14-1, Sotokanda, Chiyoda-ku, Tokyo 101-0021 JAPAN

Tel: + 81 3 5207 8249 Fax: +81 3 5298 5362

URL <https://www.smcworld.com>

Note: Specifications are subject to change without prior notice and any obligation on the part of the manufacturer.

© 2019 SMC Corporation All Rights Reserved