



No: XL\*\*\*\*\*-OML0011

First Edition: Des,2007

Revised :

# Operation Manual

## High Vacuum L Type Valve

*Model / Name*

## XLFR Series

*Model / Series*

Thank you for purchasing SMC product.

For appropriate operation of this product, please read this operation manual thoroughly to understand.

Also, refer to the drawing, product information for structure and specification of this product, Confirm operating environment is within specifications.

Keep this operation manual with care so that it can be used at any time.

Contents of this operation manual is subject to change without notice.

**SMC CORPORATION**

	Page
Safety Instructions.....	3
1. Precautions on handling 1.....	5
(Precautions on Design, Selection, Mounting, Piping, Maintenance)	
2. Precautions on handling 2.....	6
(Maintenance parts)	
3. Specifications.....	7
4. Construction.....	8
5. Adjustment of the bypass valve.....	9
6. Dimensions.....	10
7. Guaranteed term and guaranteed range.....	11
8. Parts replacement procedure.....	12





# Safety instructions

These safety instructions are intended to prevent a hazardous situation and/or equipment damage. These instructions indicate the level of potential hazard with the labels of “**Caution**”, “**Warning**” or “**Danger**”. They are all important notes for safety and must be followed in addition to International Standards (ISO/IEC), Japan Industrial Standards (JIS)<sup>\*1)</sup> and other safety regulations<sup>\*2)</sup>.

- \*1) ISO 4414: Pneumatic fluid power --- General rules relating to systems.
- ISO 4413: Hydraulic fluid power --- General rules relating to systems.
- IEC 60204-1: Safety of machinery --- Electrical equipment of machines. (Part 1: General requirements)
- ISO 10218-1992: Manipulating industrial robots-Safety.
- JIS B 8370: General rules for pneumatic equipment.
- JIS B 8361: General rules for hydraulic equipment.
- JIS B9960-1: Safety of machinery-Electrical equipment of machines.(Part 1: General requirements)
- JIS B 8433-1993: Manipulating industrial robots-Safety.
- etc.

\*2) Labor Safety and Sanitation Law, etc.

 **Caution** : Operator error could result in injury or equipment damage.

 **Warning** : Operator error could result in serious injury or loss of life.

 **Danger** : In extreme conditions, there is a possibility of serious injury or loss of life.

 **Warning**

- 1. The compatibility of the product is the responsibility of the person who designs the equipment or decides its specifications.**  
 Since the product specified here is used under various operating conditions, its compatibility with specific equipment must be decided by the person who designs the equipment or decides its specifications based on necessary analysis and test results. The expected performance and safety assurance of the equipment will be the responsibility of the person who has determined its compatibility with the product. This person should also continuously review all specifications of the product referring to its latest catalog information, with a view to giving due consideration to any possibility of equipment failure when configuring the equipment.
- 2. Only personnel with appropriate training should operate machinery and equipment.**  
 The product specified here may become unsafe if handled incorrectly. The assembly, operation and maintenance of machines or equipment including our products must be performed by an operator who is appropriately trained and experienced.
- 3. Do not service or attempt to remove product and machinery / equipment until safety is confirmed.**
  1. The inspection and maintenance of machinery / equipment should only be performed after measures to prevent falling or runaway of the driven objects have been confirmed.
  2. When the product is to be removed, confirm that the safety measures as mentioned above are implemented and the power from any appropriate source is cut, and read and understand the specific product precautions of all relevant products carefully.
  3. Before machinery / equipment is restarted, take measures to prevent unexpected operation and malfunction.
- 4. Contact SMC beforehand and take special consideration of safety measures if the product is to be used in any of the following conditions.**
  1. Conditions and environments outside of the given specifications, or use outdoors or in a place exposed to direct sunlight.
  2. Installation on equipment in conjunction with atomic energy, railway, air navigation, space, shipping, vehicles, military, medical treatment, combustion and recreation, or equipment contact

With food and beverages, emergency stop circuits, clutch and brake circuits in press applications, safety equipment or other applications unsuitable for the standard specifications described in the product catalog.

3. An application which could have negative effects on people, property, or animals requiring special safety analysis.

4. Use in an interlock circuit, which requires the provision of double interlock for possible failure by using a mechanical protective function, and periodical checks to confirm proper operation.

### **Caution**

#### **1. The product is provided for use in manufacturing industries.**

The product herein described is basically provided for peaceful use in manufacturing industries. If considering using the product in other industries, consult SMC beforehand and exchange specifications or a contract if necessary.

If anything is unclear, contact your nearest sales branch.

## **Limited warranty and Disclaimer / Compliance Requirements**

The product used is subject to the following " Limited warranty and Disclaimer " and " Compliance Requirements". Read and accept them before using the product.

### **Limited warranty and Disclaimer**

1) The warranty period of the product is 1 year in service or 1.5 years after the product is delivered.

Also, the product may have specified durability, running distance or replacement parts. Please consult your nearest sales branch.

2) For any failure or damage reported within the warranty period which is clearly our responsibility, a replacement product or necessary parts will be provided.

This limited warranty applies only to our product independently, and not to any other damage incurred due to the failure of the product.

### **Compliance Requirements**

When the product is exported, strictly follow the laws required by the Ministry of Economy, Trade and Industry (Foreign Exchange and Foreign Trade Control Law).



## Common Specific Precautions 1 Be sure to read before handling.

### Precautions on Design



## Warning

### ● All models

- (1) The body material is A6061, A6063, the bellows is SUS316L, and other metal seal material is SUS304. Standard seal material in the vacuum section is FKM. Grease for vacuum (Fluorine grease : Y VAC 2) is applied to axis seal and fixed seal of vacuum area. Use fluids those are compatible with using materials after confirming.
- (2) Select the material of operating pressure material and the fitting which temperature resistance is appropriate for operating temperature.
- (3) Set the switch temperature at 60°C.

### Selection



## Caution

### ● All models

- (1) When controlling valve responsiveness, take note of the size and length of piping, as well as the flow rate characteristics of the actuating solenoid valve.
- (2) Actuating press should be kept within the specified range. 0.4 MPa to 0.5 MPa is recommended.
- (3) Use within the limits of the operating pressure range.
- (4) For gas which generate deposition, preventive action against depositing needs to be taken.

### Mounting



## Caution

### ● All models

- (1) In high humidity environments, keep valves packed until the time of installation
- (2) Perform piping so that excessive force is not applied to the flange sections. In case there is vibration of heavy objects or attachments, secure them so that torque is not applied directly to the flanges.
- (3) In case with switches, secure the lead wires so that they have sufficient slack, without any unreasonable force applied to them.

### ● High temperature types; (Temperature specifications/H0)

- (1) When a valve is to be heated, only the body section should be heated, excluding the bonnet section.

### Piping



## Caution

- (1) Before mounting, clean the surface of the flange seal and the O-ring with ethanol, etc.

- (2) There is an indentation of 0.1 to 0.2mm in order to protect the flange seal surface, and it should be handled so that the seal surface is not damaged in any way.

Maintenance

**Warning**

If the fluid or reaction product (deposit) may deteriorate safety, those who have domain knowledge and experience (specialist of the field) shall disassemble, clean and assemble the products.

**Caution**

- (1) When removing deposits from a valve, take care not to damage any of its parts.
- (2) Replace the bonnet assembly or O ring when the end of its service life is approached.
- (3) If damage is suspected prior to the end of the service life, perform early maintenance.
- (4) SMC specified parts should be used for service. Refer to the Construction / Maintenance parts table.
- (5) When removing valve or exterior seals, take care not to damage the sealing surfaces. When installing the valve seal, be sure that the O-ring is not twisted.

2. Precautions on handling 2

**Common Specific Precautions 2**

Maintenance Parts

Be sure to read before handling

**Maintenance parts      Part no.**

Description	Valve model no.		
	XLFR-80 *	XLFR-100 *	XLFR-160 *
Bonnet Ass'y ② Note2)	XLF80 *-30-1 *	XLF100 *-30-1 *	XLF160 *-30-1 *
Bypass valve ③ Noto2)	XLA-16 *-X65		
O-Ring ④	B2401-V85V	AS568-349V	B2401-G155V
O-Ring ⑤	AS568-045V	AS568-050V	AS568-167V
O-Ring ⑥	AS568-017V		
O-Ring ⑦	B2401-V15V		
O-Ring ⑧	AS568-025V		

Note 1) Number in description indicates the number in construction drawing. Refer to construction drawing.

Note 2) The part number with asterisk is for an optional part. For the details of the optional parts, check the assembly drawing.

**Grease for maintenance      Part no.**

Description	Part no.(Manufacturer)
Vacuum grease	FONMBLIN Y VAC 2 ( Solvay Solexis(used to be Ausimont) )

### 3. Specifications

Model		XLFR-80*	XLFR-100*	XLFR-160*
Valve size		80	100	160
Actuating type	Main exhaust valve	Normal close (NC)		
	Bypass valve	Normal close (NC)		
Fluid		Vacuum with inert gas		
Operating temperature °C		5 to 60°C(5 to 150 for high temperature type)		
Operating pressure Pa		Atmospheric pressure to $1 \times 10^{-5}$		
Conductance l/s Note 1	Main exhaust valve	200	300	800
	Bypass valve	MAX25/1pc, (Viscous flow)	MAX31.5/1pc, (Viscous flow)	
Leakage Pa·m <sup>3</sup> /s	Internal	$1.3 \times 10^{-9}$ at normal temp. – except gas permeation		
	External	$1.3 \times 10^{-9}$ at normal temp. – except gas permeation		
Flange type		KF(NW)80	KF(NW)100	KF(NW)160
Main material Note 2		Body : A6063、A6061、 Critical parts : SUS304 Seal material:FKM		
Surface treatment for body		Outside : Hard anodizing, Inside : No treatment		
Actuation pressure MPa		0.4 to 0.7		
Port size	Main exhaust valve	Rc1/8		
	Bypass valve	M5		
Air consumption cm <sup>3</sup> at 0.5MPa Note 3	Main exhaust valve	1350	3000	5150
	Bypass valve	19		
Weight kg		5.6	11.4	18.7

Note 1 The conductance is “molecular flow” measured with an elbow pipe which has the same dimension with each flange.

The conductance of the bypass valve is the value of “viscous flow”.

Note 2 Vacuum grease (Y-VAC 2) is applied to axis seal and fixed seal at vacuum area.

Note 3 Air consumed by a reciprocating motion of a cylinder.

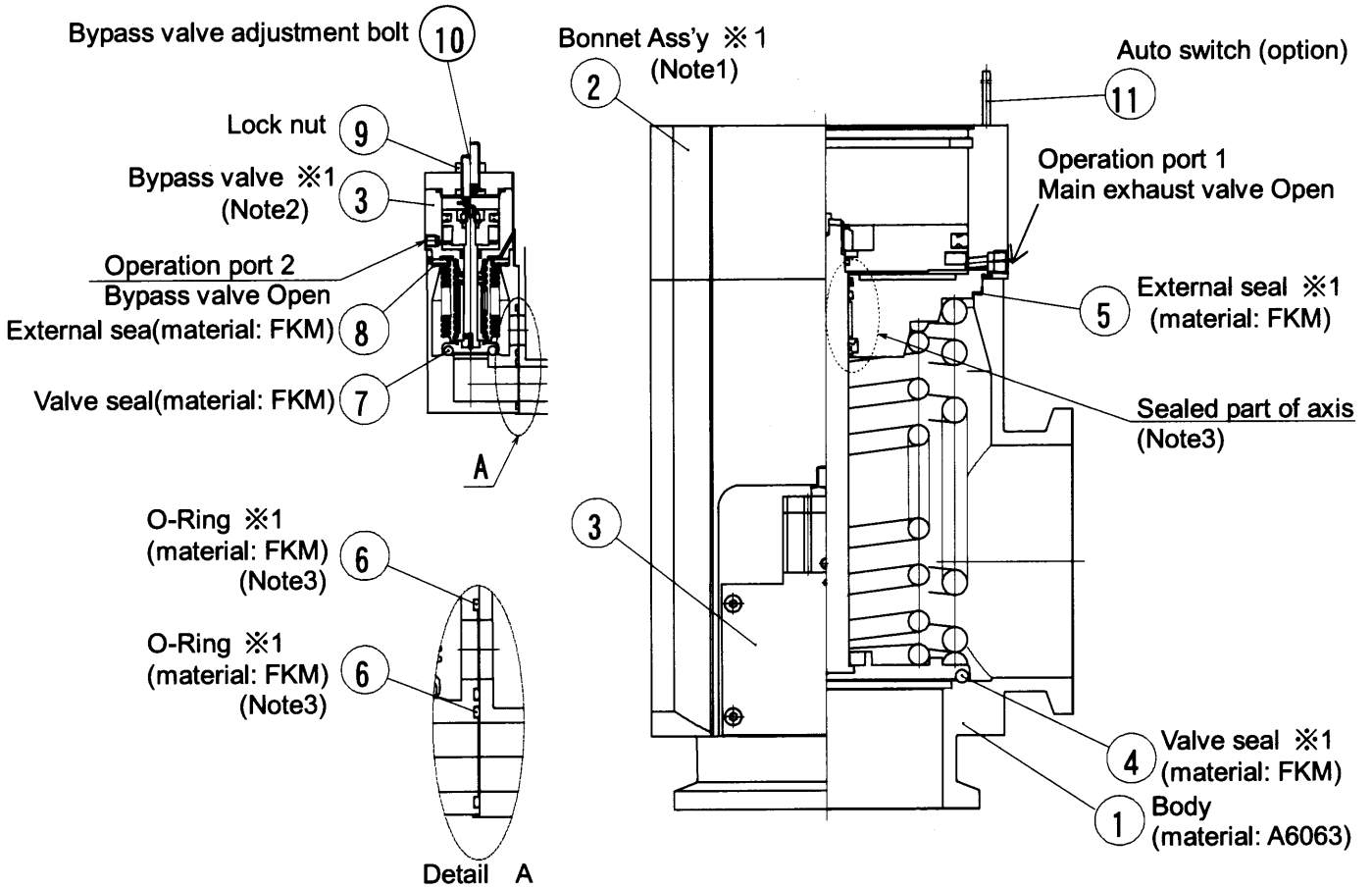

※ 1 indicates maintenance parts

Note 1 Bonnet Ass'y does not include ⑤O-ring

Note 2 Bypass valve does not include ⑥O-ring

Note 3 Vacuum grease(Y VAC2-)is applied to axis seal and ⑥O-ring

• Bypass valve open degree adjustment

Adjust the open degree of the bypass valve before operation. Refer to "5. Adjustment of the bypass valve".

• Operation

1), Main exhaust valve

The valve is separated from the body seat and open by applying pressure to the operation port 1.

The valve returns to seal by extracting pressure from operation port 1.

2. Bypass valve

The valve is separated from the body seat and open up to specified amount by applying pressure to operation port 2.

The valve returns to seal by extracting pressure from operation port 2.



## 5. Adjustment of the bypass valve

### • Adjustment of the bypass valve

Adjust the bypass valve by changing the open amount of the valve.

Bypass valve stroke can be adjusted within 1 to 5mm(Note 1)

#### 1. Loosen lock nut⑨ to release locking.

Hold bypass valve adjusting bolt⑩ with hexagon wrench to loosen the lock nut. (Fig.1)

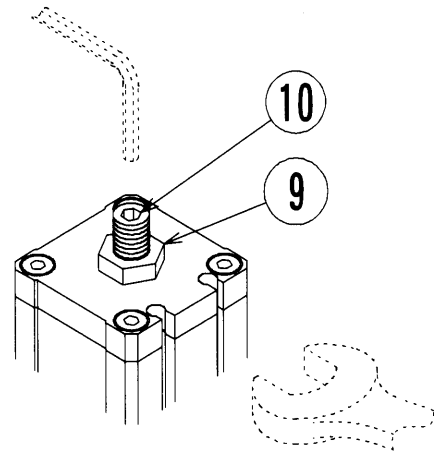

Fig.1

#### 2. Keep turning bypass valve adjusting bolt⑩ clockwise.

Open amount becomes zero when it stops turning lightly. (Fig.2)

Open amount becomes larger by turning counterclockwise.

- Adjustment pitch : 1mm/turn

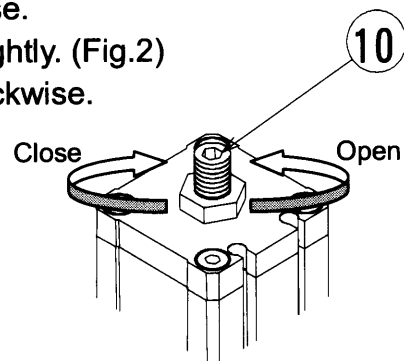

Fig.2

#### 3. Tighten lock nut⑨ when adjustment completed.

Note 1 To avoid the damage of O-ring and adjustment part, do not turn bypass valve adjusting bolt⑩ farther than the point where turning is stopped at both ends.

Note 2 Do not apply pressure to the operation port during adjustment.

Note 3 Bypass valve is fully open at ex-factory.

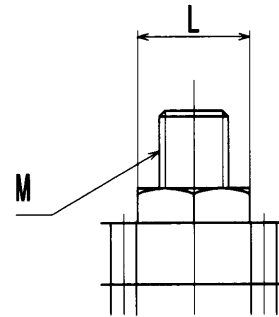
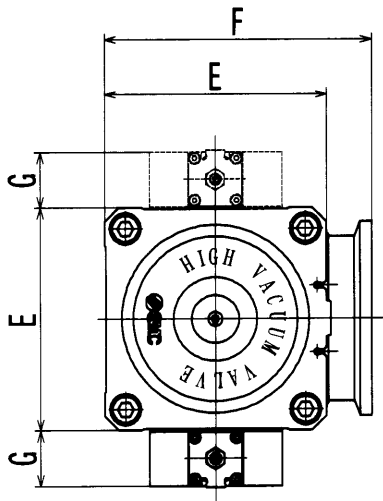

Detail Z

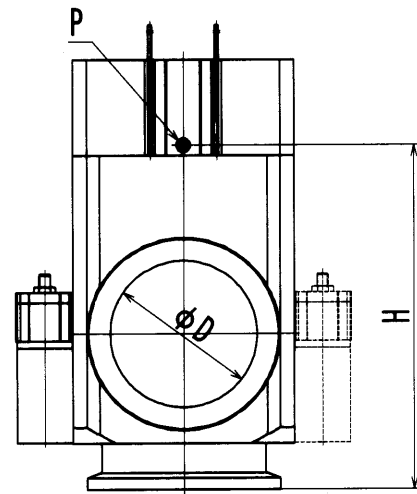
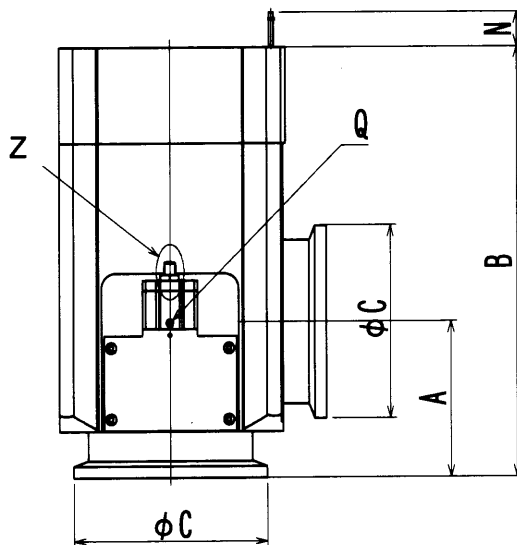

Dimension

in mm

Model	A	B	C	D	E	F	G
XLFR-80*	90	235	114	83	117	148.5	40
XLFR-100*	108	299	134	102	154	185	40
XLFR-160*	138	315	190	153	200	238	40

Model	H	L	M	N	P	Q
XLFR-80*	186	13	M8	500	Rc1/8	M5
XLFR-100*	211	13	M8	500	Rc1/8	M5
XLFR-160*	274	13	M8	500	Rc1/8	M5

Note 1 M dimension indicates bolt size

Note 2 N dimension indicates the switch lead wire length (L type is 3000 mm)

The guaranteed period covers the period which finishes the earliest among followings; (1)1 million operating cycles (with durability test condition of SMC), (2)18 months after shipping from SMC, (3)12 months after customer starting the use of the product at your place or your customer's place.

Note 1) : The product durability depends on operating conditions (ex. operating fluid).

If the specification is not followed, or any non-conformance derived from mounting or replace of a device, an assembly, or an O-ring at your place occurs, the guarantee cannot be applied.

If any failure occurs due to our fault during the guaranteed period, we will guarantee the non-conformance by delivering a substitute in the worst case. However, responsibility of any damage which is led by the failure of delivered product is not taken by us.

Result of durability test (with the circuit shown on the right)

Internal/ external leakage and operation were checked by opening and closing a valve in internally evacuated condition at ordinary temperature (room temperature). It was confirmed that specification was satisfied until 1 million cycles.

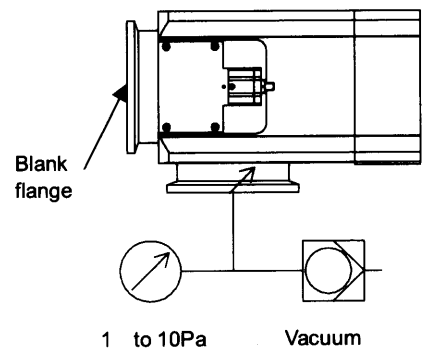

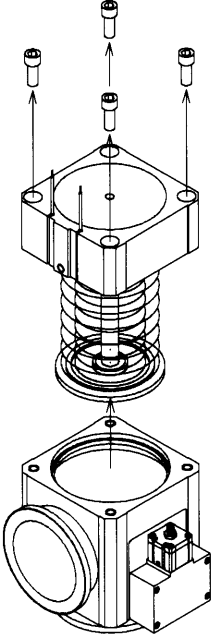
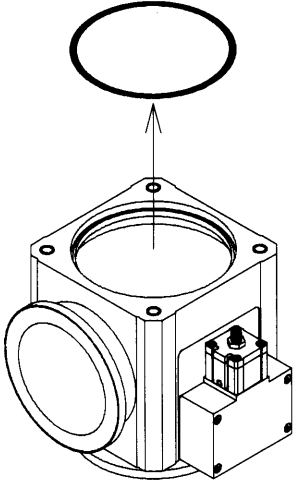
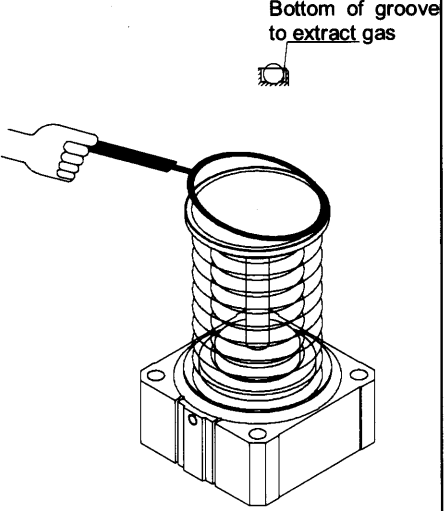
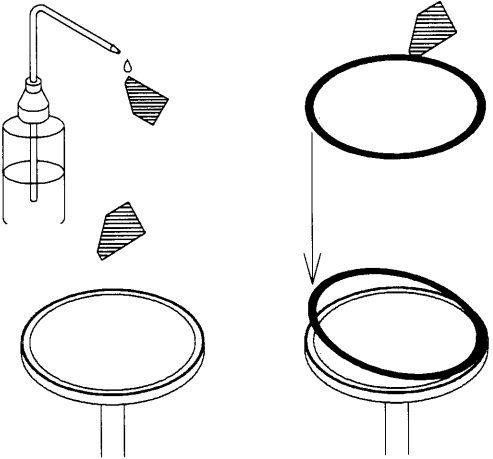
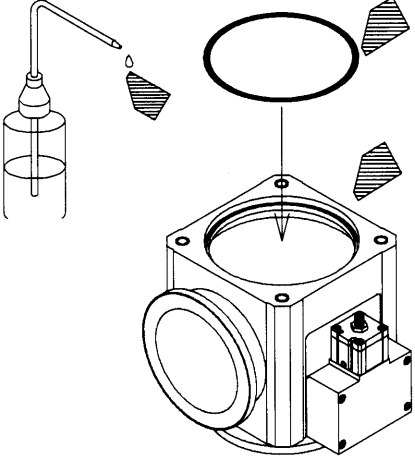
Description	Main valve seal Parts replacement procedure				
Responsible Dept.	Type	High vacuum angled valve	Model no.	XLFR	
<p><b>Procedure1, Valve disassembly</b></p>  <p>Apply 0.4Mpa to operation port. Loosen bolts in cross-bolting pattern gradually to disassemble.</p>	<p><b>Procedure2, Remove external seal</b></p>  <p>Remove O-ring from the body.</p> <p>Note 1) Attention should be taken not to damage O-ring mount surface.</p>	<p><b>Procedure3, Remove internal seal</b></p>  <p>Remove the seal from the place at O-ring groove to extract gas by the tool which height is the same as the bottom of gas extracting part.</p> <p>Note 1) Attention should be taken not to damage O-ring groove.</p>			
<p><b>Procedure 4, Mounting internal seal</b></p>  <p>Apply ethanol to clean cloth to wipe off dust on valve's O-ring groove, and O-ring surface. Place O-ring onto O-ring groove, and press it diagonally to mount. Use SMC specified maintenance part(see page 5, Maintenance parts). Note 1 ) Use gloves which do not generate particles Note2 ) Ensure O-ring is placed properly(Not twisted, not waving )</p>	<p><b>Procedure 5, Mounting external seal</b></p>  <p>Apply ethanol to clean cloth to wipe off dust on valve's O-ring groove, and O-ring surface. Place O-ring onto O-ring groove, and press it diagonally to mount. Use SMC specified maintenance part(see page 5, Maintenance parts). Note 1 ) Use gloves which do not generate particles Note2 ) Ensure O-ring is placed properly(Not twisted, not waving )</p>				

Description	Main valve seal Parts replacement procedure				
Responsible Dept.		Type	High vacuum angled valve	Model no	XLFR

Procedure 6, Valve assembly

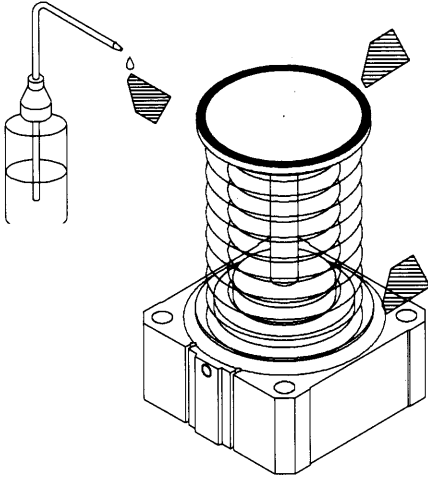

Apply ethanol to clean cloth to wipe off dust on valve's O-ring groove, and O-ring surface.  
 Apply 0.4MPa to operation port, and mount the bonnet Ass'y to the body. Tighten bolts in cross-bolting pattern.  
 First, tighten manually until just before compressing O-ring. Then, tighten entirely.

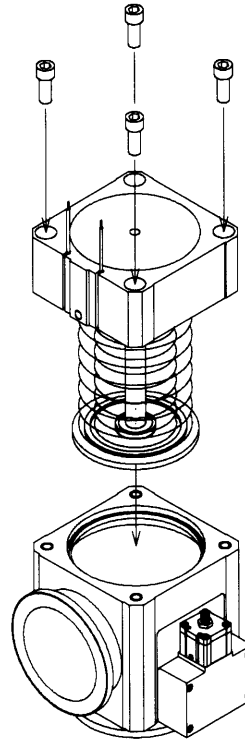

Procedure 7, Mounting/removal of bypass valve

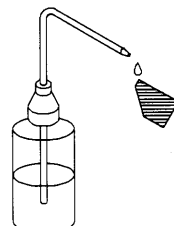
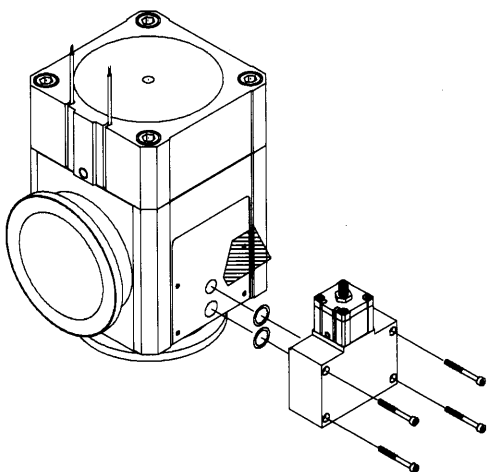

Apply grease

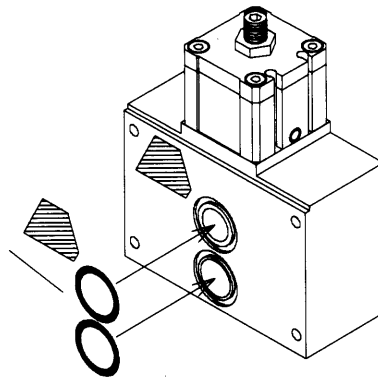

- Remove the bypass valve  
Loosen the bolt in cross-bolting pattern, and remove the bypass valve.
  - Mount the bypass valve  
Apply ethanol to clean cloth to wipe off dust on the body seat, bypass valve's O-ring groove, and O-ring surface  
Apply grease to O-RING(2 pcs.) and mount to the groove.  
Mount the bypass valve to the body, Tighten bolts in cross-bolting pattern gradually.  
First, tighten bolts manually. Then, tighten entirely.  
To replace O-ring, use SMC specified maintenance part, and maintenance grease(see page 5, Maintenance parts).
- Note 1 ) Use lint free gloves

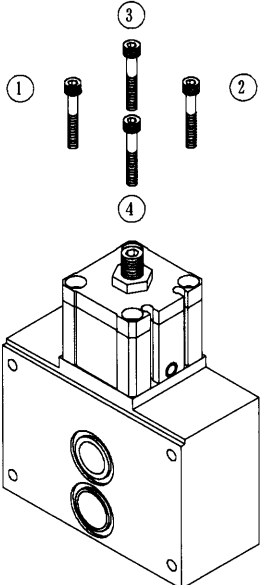
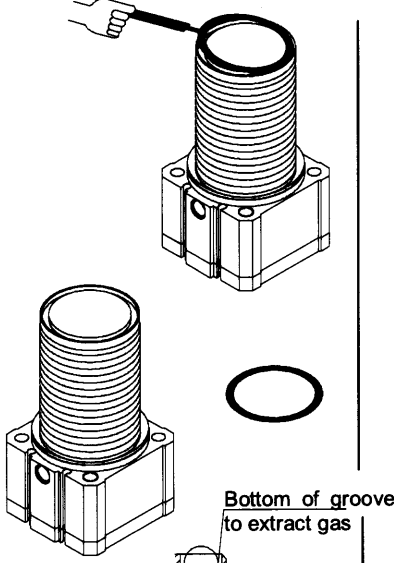
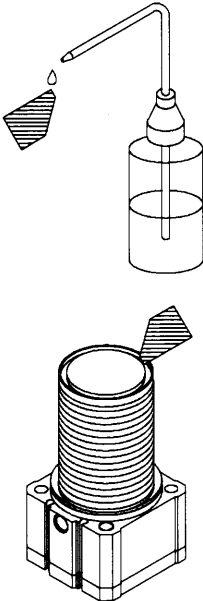
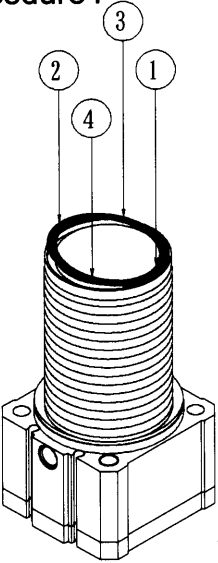
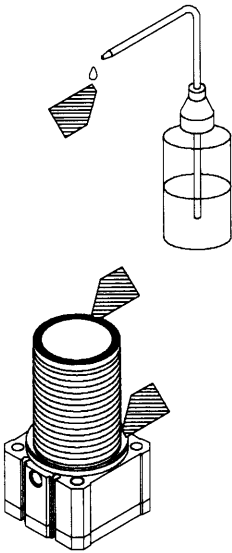
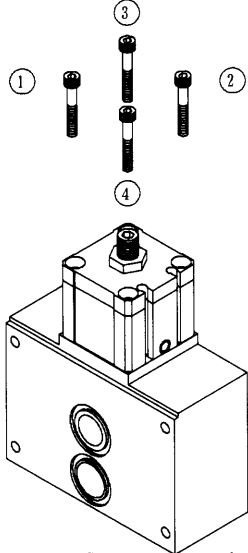
Description	Bypass, valve seal Parts replacement procedure				
Responsible Dept.		Type	High vacuum valve	Model no.	XLFR
<div style="display: flex; justify-content: space-around;"> <span>Procedure1</span> <span>Procedure2</span> <span>Procedure3</span> </div>					
<div style="display: flex; justify-content: space-between;"> <div style="width: 30%; border-right: 1px solid black; padding-right: 10px;">  <p data-bbox="236 965 614 1048">Apply 0.4Mpa to operation port. Loosen bolts in order of number above.</p> </div> <div style="width: 30%; border-right: 1px solid black; padding-right: 10px;">  <p data-bbox="651 936 1023 1048">Remove the seal from the place at O-ring groove to extract gas by the tool which height is the same as the bottom of gas extracting part.</p> <p data-bbox="651 1081 1023 1137">Note 1) Attention should be taken not to damage O-ring groove.</p> </div> <div style="width: 30%; padding-left: 10px;">  <p data-bbox="1054 976 1406 1122">Apply ethanol to clean cloth(Bemcot) to wipe off dust in O-ring groove. (Ensure no lint, or dust is on the surface)</p> </div> </div>					
<div style="display: flex; justify-content: space-around;"> <span>Procedure4</span> <span>Procedure5</span> <span>Procedure6</span> </div>					
<div style="display: flex; justify-content: space-between;"> <div style="width: 30%; border-right: 1px solid black; padding-right: 10px;">  <p data-bbox="193 1783 600 1955">Apply ethanol to clean cloth(Bemcot) to wipe off dust in O-ring groove and place it onto O-ring. Press O-ring in order of number above to mount O-ring in the groove. Use lint free gloves</p> </div> <div style="width: 30%; border-right: 1px solid black; padding-right: 10px;">  <p data-bbox="647 1816 979 1872">Apply ethanol to clean cloth(Bemcot) to wipe off dust</p> </div> <div style="width: 30%; padding-left: 10px;">  <p data-bbox="1034 1776 1414 1951">Apply 0.4MPa to operation port, and tighten bolts in order of number above. First, tighten manually until just before compressing O-ring. Then, tighten entirely.</p> </div> </div>					

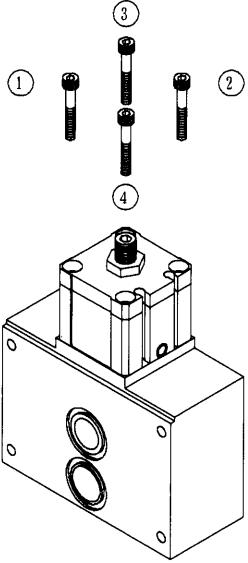
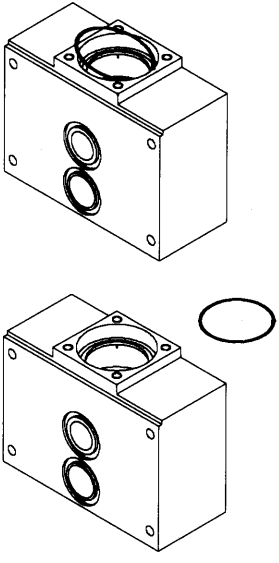
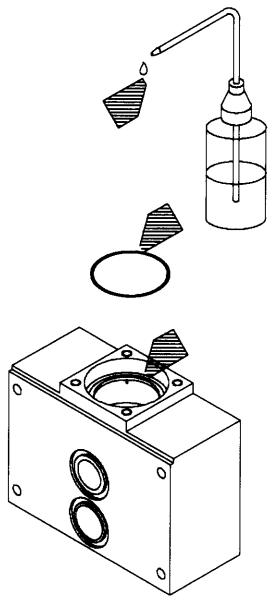
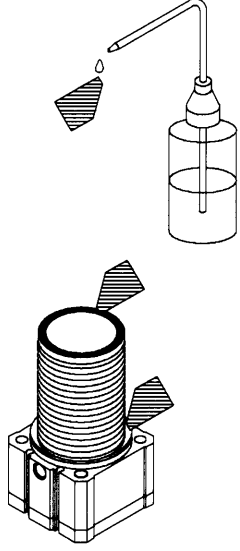
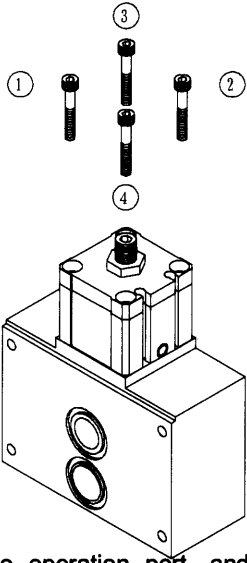
Description	Bypass valve Seal Parts replacement procedure					
Responsible Dept.		Type	High vacuum valve	Model no.	XLFR	
<div style="display: flex; justify-content: space-around;"> <span>Procedure1</span> <span>Procedure2</span> <span>Procedure3</span> </div>						
<div style="display: flex; justify-content: space-around;">    </div>						
<div style="display: flex; justify-content: space-around;"> <div style="width: 30%;"> <p>Apply 0.4Mpa to operation port. Loosen bolts in order of number above gradually.</p> </div> <div style="width: 30%;"> <p>Take O-ring out of the body. (Attention should be taken not to damage body mount surface)</p> </div> <div style="width: 30%;"> <p>Apply ethanol to clean cloth(Bemcot) to wipe off dust on O-ring surface and body mount surface. After that, mount O-ring.</p> </div> </div>						
<div style="display: flex; justify-content: space-around;"> <span>Procedure 4</span> <span>Procedure 5</span> </div>						
<div style="display: flex; justify-content: space-around;">   </div>						
<div style="display: flex; justify-content: space-around;"> <div style="width: 45%;"> <p>Apply ethanol to clean cloth(Bemcot) to wipe off dust on O-ring surface and bellows holder surface.</p> </div> <div style="width: 45%;"> <p>Apply 0.4MPa to operation port, and tighten bolts in order of number above. First, tighten manually until just before compressing O-ring. Then, tighten entirely.</p> </div> </div>						