



# Operation Manual

PRODUCT NAME

***Parallel Seal Type Slit Valve***

MODEL / Series / Product Number

XGTP31 \* -50336- \* \* \*

**SMC Corporation**

# Contents

Safety Instructions	P2~3
1. Specifications	P4
2. How to Order	P5
3. Construction/Operation	P6~8
4. Precautions	P8~9
5. Spare Parts List	P10
6. Maintenance	P10
7. Troubleshooting	P11
Attachment: Maintenance Procedure	P12~16



# Slit Valve Safety Instructions

These safety instructions are intended to prevent hazardous situations and/or equipment damage. These instructions indicate the level of potential hazard with the labels of "Caution," "Warning" or "Danger." They are all important notes for safety and must be followed in addition to International Standards (ISO/IEC)\* 1), and other safety regulations.

\*1) ISO 4414: Pneumatic fluid power -- General rules relating to systems

ISO 4413: Hydraulic fluid power -- General rules relating to systems

IEC 60204-1: Safety of machinery-- Electrical equipment of machines (Part 1: General requirements)

ISO 10218-1992: Manipulating industrial robots-Safety



## Caution

Caution indicates a hazard with a low level of risk which, if not avoided, could result in minor or moderate injury.



## Warning

Warning indicates a hazard with a medium level of risk which, if not avoided, could result in death or serious injury.



## Danger

Danger indicates a hazard with a high level of risk which, if not avoided, will result in death or serious injury.



## Warning

### **1. The compatibility of the product is the responsibility of the person who designs the equipment or decides its specifications.**

Since the product specified here is used under various operating conditions, its compatibility with specific equipment must be decided by the person who designs the equipment or decides its specifications based on necessary analysis and test results. The expected performance and safety assurance of the equipment will be the responsibility of the person who has determined its compatibility with the product. This person should also continuously review all specifications of the product referring to its latest catalog information, with a view to giving due consideration to any possibility of equipment failure when configuring the equipment.

### **2. Only personnel with appropriate training should operate machinery and equipment.**

The product specified here may become unsafe if handled incorrectly. The assembly, operation and maintenance of machines or equipment including our products must be performed by an operator who is appropriately trained and experienced.

### **3. Do not service or attempt to remove product and machinery/equipment until safety is confirmed.**

1. The inspection and maintenance of machinery/equipment should only be performed after measures to prevent falling or runaway of the driven objects have been confirmed.

2. When the product is to be removed, confirm that the safety measures as mentioned above are implemented and the power from any appropriate source is cut, and read and understand the specific product precautions of all relevant products carefully.

3. Before machinery/equipment is restarted, take measures to prevent unexpected operation and malfunction.

### **4. Contact SMC beforehand and take special consideration of safety measures if the product is to be used in any of the following conditions.**

1. Conditions and environments outside of the given specifications, or use outdoors or in a place exposed to direct sunlight.

2. Installation on equipment in conjunction with atomic energy, railways, air navigation, space, shipping, vehicles, military, medical treatment, combustion and recreation, or equipment in contact with food and beverages, emergency stop circuits, clutch and brake circuits in press applications, safety equipment or other applications unsuitable for the standard specifications described in the product catalog.

3. An application which could have negative effects on people, property, or animals requiring special safety analysis.

4. Use in an interlock circuit, which requires the provision of double interlock for possible failure by using a mechanical protective function, and periodical checks to confirm proper operation.



# Slit Valve Safety Instructions



## Caution

**The product is provided for use in manufacturing industries.**

The product herein described is basically provided for peaceful use in manufacturing industries. If considering using the product in other industries, consult SMC beforehand and exchange specifications or a contract if necessary.

If anything is unclear, contact your nearest sales branch.

## Limited warranty and Disclaimer/Compliance Requirements

The product used is subject to the following “Limited warranty and Disclaimer” and “Compliance Requirements”. Read and accept them before using the product.

### Limited warranty and Disclaimer

1. The warranty period of the product is 1 year in service or 1.5 years after the product is delivered, whichever is first.

Also, the product may have specified durability, running distance or replacement parts. Please consult your nearest sales branch.

2. For any failure or damage reported within the warranty period which is clearly our responsibility, a replacement product or necessary parts will be provided.

This limited warranty applies only to our product independently, and not to any other damage incurred due to the failure of the product.

3. Prior to using SMC products, please read and understand the warranty terms and disclaimers noted in the specified catalog for the particular products.

### Compliance Requirements

1. The use of SMC products with production equipment for the manufacture of weapons of mass destruction (WMD) or any other weapon is strictly prohibited.

2. The exports of SMC products or technology from one country to another are governed by the relevant security laws and regulations of the countries involved in the transaction. Prior to the shipment of a SMC product to another country, assure that all local rules governing that export are known and followed.

**Safety Instructions** Be sure to read the “Handling Precautions for SMC Products” (M-E03-3) and “Operation Manual” before use.

## 1. Specifications

Opening size		50mm×336mm	
Operating pressure		Atmospheric pressure~10 <sup>-6</sup> Pa	
Pilot pressure		0.45~0.6 MPa	
Internal leakage *1		O-Ring Material : FKM	6.5×10 <sup>-10</sup> Pa·m <sup>3</sup> /sec
		O-Ring Material : Kalrez®	6.5×10 <sup>-9</sup> Pa·m <sup>3</sup> /sec
Internal leakage at Back pressure *1 〈Back pressure 0.1MPa(abs) or less〉		O-Ring Material : FKM	6.5×10 <sup>-8</sup> Pa·m <sup>3</sup> /sec
		O-Ring Material : Kalrez®	6.5×10 <sup>-7</sup> Pa·m <sup>3</sup> /sec
External Leakage *1		6.5×10 <sup>-11</sup> Pa·m <sup>3</sup> /sec	
Operating temperature		Gate Part : 5~120°C(During bake-out : 150°C) Actuator part : 5~90°C (Except Auto switch)	
Fluid		Inert gas	
Operating Time		1 sec or less *2	
Auto switch		D-A93 (Operating temperature : 20~60°C)	
Main material of vacuum part	Seal material	FKM	
	Mechanical parts	Bellows : AM350 Gate : A6063 Body : A5052 Bonnet : A6061 Gate bolt : SUS316 Others : SUS304	
Piping size		Rc1/8	
Exhaust direction		Free	
End-Lock ( End lock type)		With lock mechanism in opened or FULL sea position	
Mounting Direction		Vertical	
Cylinder Volume		0.2 ℓ	
Mass		<ul style="list-style-type: none"> <li>• Insert type : 10kg</li> <li>• Cassette type (Standard) : 14.5kg</li> <li>• Cassette type (Half MESC) : 13.5kg</li> </ul>	

\*1: At normal temperature. Gas permeation is not included.(SMC's inspection conditions)

\*2: The period of time from gate open state to clamp after signals comes to solenoid valve and from gate clam

〈Conditions〉

- Pressure: 0.5MPa ,
- Pipe length:1m,
- Gate Direction: Vertical Upper,
- Without Speed Controller,
- Solenoid Valve:SY5120-01 ,
- Tube:TU0604



### 3. Construction/Operation

Bonnet ASSY

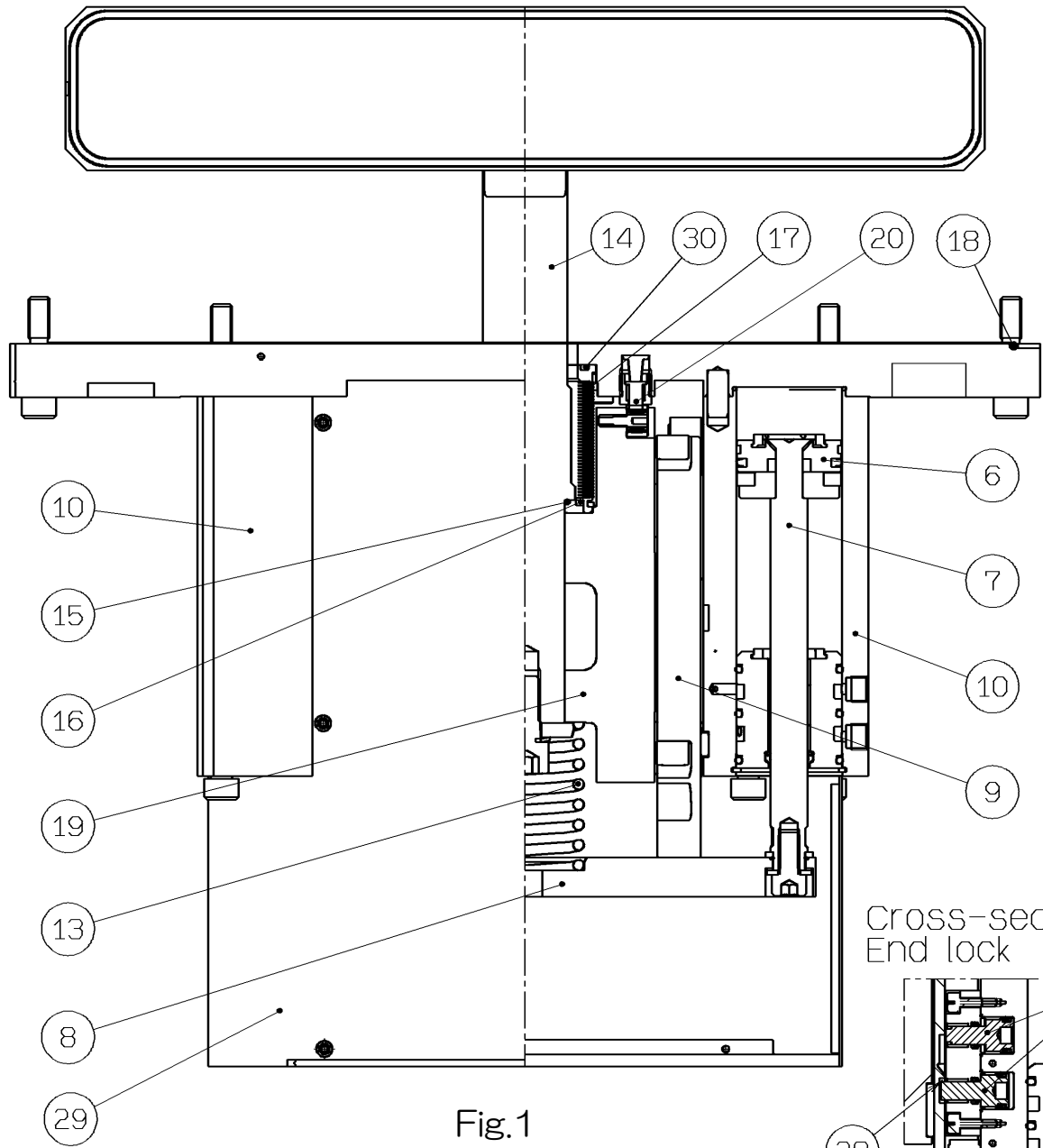

Fig.1

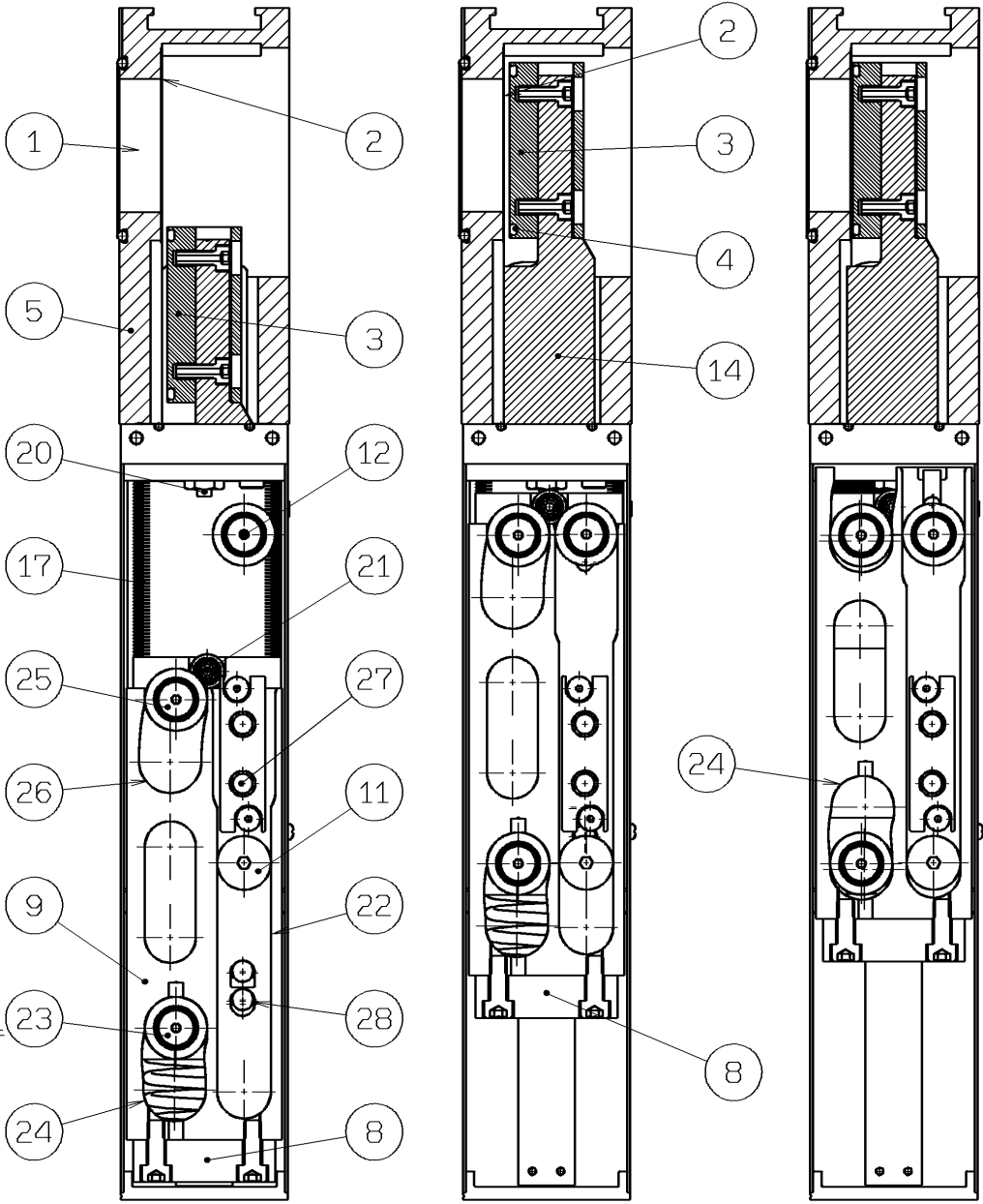
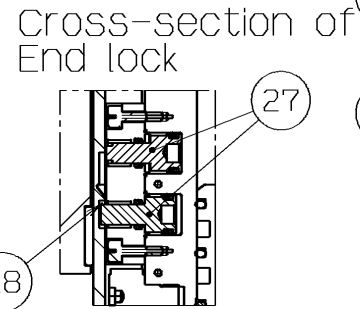

Fig.2A : OPEN Fig.2B : CLOSE Fig.2C : CLAMP

### 3-1 Operation

Figures 1 and 2B show the state in which Slit ① carrying the work piece is closed and Gate ③ (Sealing material ④) is not clamped (sealed) on Seal surface ②.

In Fig. 2A shows Slit valve opens and Slit ① of the body ⑤ is released. So it is a state where the work piece can be transported.

Figure 2C shows a state in which Gate ③ is clamped and Seal surface ② is sealed by Sealing material ④ of Gate ③.

### 3-2 Construction

In Figures 1 and 2, Piston rod ⑦ integrated with Piston ⑥ and Moving base ⑧ are connected by a displaceable mechanism. And Roller block ⑨ is fixed to Moving base ⑧. In addition, Shaft ⑭ fixed to Lever ⑰ is separated from each other by the force of Moving base ⑧ and Spring ⑬. On the other hand, since Lever ⑰ is restricted by Roller block ⑨ and Roller block ⑨ that is guided by Cylinder tube ⑩ and Cam follower ⑪⑫ attached there. So Shaft ⑭ and Roller block ⑨ are mated by reacting force of Spring ⑬ then it is possible to move up and down together. Also regarding the external seal, Shaft⑭ moving up and down is done with Bellows ASSY ⑰ and O-ring ⑮⑯⑰. And Static seal part of Bonnet ASSY and Body ⑤ is done with O-ring ⑱.

### 3-3 At the case Gate CLOSE (Fig2A⇒Fig2B)

By pressurizing to "CLOSE" side port (exhausting "OPEN" side), Moving base ⑧ that is connected to Piston rods ⑦ are moving up. On the other hand, since Moving base ⑧ pushes up Shaft ⑭ integrated with Lever ⑰ by Spring ⑬, Lever ⑰, Shaft ⑭ and Gate ③ attached to it also go up at the same time, then Cam follower C ⑳ comes into contact with Stopper ㉑ and stop the up motion and Slit ① of Body ⑤ is closed.

In FIG. 2B, the left and right positions of Roller block ⑨ and Lever ⑰ are restricted by Cam grooves ㉒ ㉓ of Roller block ⑨ and Cam followers A ㉔ and B ㉕. Furthermore, the position of Roller block ⑨ of the left-right direction is fixed by Guide groove ㉖ of Roller block ⑨ and Cam follower ⑪⑫ fixed to the cylinder tube ⑩. The distance for the vertical direction between Lever ⑰ and Roller block ⑨ is constant because Cam groove ㉒ of Roller block ⑨ and Cam follower ㉔ come in contact and are pressed by Spring ⑬. Therefore, Shaft ⑭/Gate ③ fixed by Lever ⑰ move up stable when moving from Gate ③ OPEN position in Figure 2A to Gate ③ CLOSE position in Figure 2B.

### 3-4 At the case Gate CLAMP (Seal) (Fig.2B⇒Fig.2C)

Cam follower C ⑳ comes into contact with Stopper ㉑ then Lever ⑰/Shaft ⑭ and ③ stop. On the other hand, Piston rod ⑦ and Roller block ⑨ are further going up with compressing Spring ⑬, so Cam followers A ㉔ and B ㉕ move to the left side following the cam groove ㉒㉓ of Roller block ⑨. And along with that, Lever ⑰/ Shaft ⑭ and Gate ③ also move to the left side, and O ring ④ of the gate ③ is clamped (sealed) to the seal surface ②.

### 3-5 Unclamp(Fig.2C⇒Fig.2B)

By pressurizing to "OPEN" port side (exhausting "CLOSE" side), Moving base ⑧ and Roller block ⑨ that is connected to Piston rods ⑦ moves down, so by following Cam groove ㉒㉓ Cam follower ㉔ and Cam follower B ㉕ move to the right, along with which Shaft ⑭ and Gate ③ also move to the right side and make unclamp of Gate ③. At that time, Cam follower B ㉕ fixed to the lever ⑰ and Cam groove ㉒ of Roller block ⑨ come in contact with each other and are fixed vertically by the force of Spring ⑬. And also Cam groove ㉓ of Roller block ⑨ and Cam follower B ㉕ are fixed for the left and right direction so the left, and right directions movement are fixed.

When Roller block ⑨ moves down a slight downward force acts from Cam follower A and ㉔ Cam follower ㉕ to Lever ⑰, but because pushing up force by Spring ⑬ is greater than the downward force, Gate ③ leaves at a right angle.

### 3-6 At the case Gate OPEN(Fig.2B⇒Fig.2A)

After unclamp (unseal), Gate ③/ Shaft ⑭/ Lever ⑰ and Roller block ⑨ moves down together, then Gate ③ opens and Slit ① of Body ⑤ is released.



### 3-7 End lock (in case with End Lock)

When the air pressure suddenly disappears at the opening and closing position of Gate, End lock pin ⑦ protrudes and enters the end lock groove ⑳㉑ of Roller block ⑨ to regulate the operation of Roller block ⑨ and the valve is maintain the location before the air is lost. However, if the air pressure gradually disappears, there is a possibility that End lock will not operate properly.

## 4. Precautions

### Caution

#### 4-1. Air piping

Hold the speed controller on the piping port (Rc1/8) lightly and connect the tube. Please confirm not to apply excessive external force to the fitting. Use a 2 positions 5 port valve for the product operation.

The end lock may not operate correctly without using the 2 positions 5 port valve.

#### 4-2. Installation

Tighten the bolt for connection gradually and diagonally by constant torque to avoid application of uneven force to the bolts. When installing the bonnet assembly and gate, refer to the maintenance procedure for tightening of the bolts.

※Please make OPEN conditions when Bonnet ASSY is installed.

※Please don't make scratch at Body's seal surface when installed

※The compression of the O-rings on the user's application should be 0.7 to 0.9mm.

Otherwise, it may cause potential leak path.

※Please tighten the bolts with proper torque when installed. Otherwise Bolt and Body's threads might be damaged.

#### 4-3. Disinstallation

Please make OPEN condition when Bonnet ASSY is removed from Body at maintenance. If Bonnet ASSY is removed at CLOSE condition then Body's threads might be damaged.

#### 4-4. End lock release

When unlocking the slit valve with no air pressure applied, first apply pressure to air port which can remain current open or close position, and then release end lock and switch the solenoid valve. The gate of the slit valve is closed before shipment, so apply pressure to the closed position first.

e.g.: If the gate is opened, apply pressure to the "open" side of air piping, and switch the valve after releasing the end lock.

When Slit valve is shipped the condition of Gate is below,

1. Insert type: Gate is OPEN so please supply the pressure to OPEN port.

2. With Body type: Gate is CLOSE so please supply the pressure to CLOSE port.

#### 4-5. Speed control

Be sure to control speed to open and close the gate in meter out condition.

Otherwise, the slit valve life will be adversely affected. Improper use of speed controls can damage end-lock mechanism as well as shorten life time of valve.

#### 4-6. Exhaust piping

Please avoid to be influenced exhaust pressure from other solenoid valves to the slit valve. Such a pressure may cause improper operation of end lock of the gate.

#### 4-7. Operation of valve

- (1) Please confirm in regulated difference pressure as 4kPa and do the opening and shutting operation when you open and shut the valve.
- (2) In case Body(Chamber) and Gate is heated and cooling gradually from High Temperature to Room temperature then please make OPEN condition. If it is cooling at CLOSE condition then Gate O-ring will be stuck and when operate to OPEN condition then gate O-ring will be removed.

#### Warning

- (3) Please keep within operating pressure range to slit valve.  
If operating pressure is over the range then cylinder will be damaged and injury by broken pieces.
- (4) Do not put your hand into the slit of the body without confirming safety.  
Injury and Bodily harm will occur with the valve operated when valve is operated valve.
- (5) Do not remove the Cover (Fig.1②) on the actuating part. And if it is touched the internal actuating parts while the slit valve is operating may result in injury.
- (6) Remove the pneumatic piping for operation and make cylinder have no pressure inside for maintenance otherwise cylinder is operating and makes dangerous. When tube is removed please shut off the pressure and ensure that stored energy is removed. Otherwise tube is removed the tube will be out of control and make loss of vision to employees or injury.

#### Caution

#### 4-8. Replacement of O-ring

Use the parts shown on "4. Replacement parts list" when replacing bonnet assembly, Gate and O-rings for a gate. Give sufficient cleaning to O-ring groove and mount O-ring in it so that it will not twist. Use a plastic specific tool so as not to damage sealing faces of the O-ring groove. Refer to the maintenance manual for details.

After replacement, please implement leak inspection.

#### Warning

#### 4-9. Return of Product

If the product being returned is contaminated or possibly contaminated with substances that are harmful to humans then please contact SMC in the first instance and get the product decontaminated and made safe by a specialist cleaning company. After the decontamination prescribed in the sentence before, submit Product Return Request Sheet or Detoxification/Decontamination certificate to SMC and await return contact from SMC before returning the item to SMC.

Please refer to International Chemical Safety Cards (ICSC) for a list of the harmful substances.

If you have any questions, please contact your SMC sales representative.

## 5. Spare Parts List

### For XGTP312-50336-\*\*\*

Description	Orderable Part No	Applicable Part No	Note
Body ASSY	XGT300-1-1AS	XGTP312-50336-※※※	—

### For XGTP313-50336-\*\*\*

Description	Orderable Part No	Applicable Part No	Note
Body ASSY	XGT300-1-1-3AS	XGTP313-50336-※※※	—

## Common Spare Parts List

Description	Orderable Part No	Applicable Part No	Note
Bonnet ASSY	XGTP311-50336A1-1※	XGTP31※50336-1※※ or XGTP31※-50336-2※※	-
	XGTP311-50336A1-1A※	XGTP31※50336-※A※	-
	XGTP311-50336A1-1C※	XGTP31※50336-※C※	-
	XGTP311-50336A1-1F※	XGTP31※50336-※F※	-
Gate ASSY	XGTP300-2-1S	XGTP31※50336-※※※	-
Bellows ASSY	XGTP300-20AS	↑	-
O-ring(Body opening side)	FKM XGT300-9-10S	↑	AS568-273
O-ring(Gate)	FKM XGT300-9-9S	XGTP31※50336-1※※	AS568-271
	Kalrez <sup>®</sup> 4079 XGT300-9-11S	XGTP31※50336-2※※	
O-ring(Bonnet assembly)	FKM XGT300-9-7S	XGTP31※50336-※※※	AS568-177
Gate Bolt	XGT300-2-5S	↑	-

## How to order for Bonnet ASSY

<h1 style="margin: 0;">XGTP311 - 50336A1 - 1 ※※※</h1> <div style="display: flex; justify-content: space-around; margin-top: 10px;"> <div style="text-align: center;"> <p>Without Gate</p> </div> <div style="text-align: center;"> <p>End lock</p> <p>Nil : OPEN/CLOSE end lock N : None</p> </div> </div> <div style="text-align: center; margin-top: 10px;"> <p>Auto switch and the connector (See Table 1)</p> </div>
--

## Connected connector of Auto witch (female type)

Description	Orderable Part No	Applicable Part No	Note
Straight plug	XGT0402-9-12S	For XGTP31※50336-※C※	C016 30D006 100 12(AMP)

## 6. Maintenance

### Warning

Please refer to the attached "Procedure for maintenance".

## 7. Troubleshooting

Status	Possible cause	Countermeasure
Gate Internal leakage	Operating pressure is too low	Increase pressure to 0.45MPa or more.
	Foreign materials of Seal surface	Cleaning to Seal Surface
	Scratches on the seal surface of Gate	Replace Gate
	Scratches on the seal surface of Body	Replace Body
	Deterioration of O-ring by processing	Replace with new O-ring whose material is changed to have compatibility with processing
	Twist of O-ring	Re-install O-ring
	Come off of O-ring	Re-install O-ring
	Peeling off of O-ring	Replace O-ring
	Concave/ Convex of end of O-ring	Put the convex part into the groove to make the O-ring height the same.
	Deterioration of Bonnet Assembly	Replace Bonnet ASSY
External Leakage	Damage of Bellow ASSY	Replace Bellows ASSY
	Deterioration of O-ring by processing	Replace with new O-ring whose material is changed to have compatibility with processing
	Scratches on the seal surface	Polishing of seal surface
Gate is not possible to CLOSE	Wrong End lock operation	Please refer 4-4
	Operating pressure is too low	Increase pressure to 0.45MPa or more.
	Deterioration of Bonnet assembly	Replace Bonnet ASSY
Gate is not possible to OPEN	Wrong End lock operation	Please refer 4-4
	Operating pressure is too low	Increase pressure to 0.45MPa or more.
	Deterioration of Bonnet assembly	Replace Bonnet ASSY
Doesn't work Auto-switch	Displacement of Auto-switch	Adjust the location to detect range
	Failure of Auto-switch	Replace Auto-switch
	Operating pressure is too low	Increase pressure to 0.45MPa or more.
Air Leakage of Bonnet ASSY	Loosening of connection	Replace Bonnet ASSY
	Wear of piston sea	Replace Bonnet ASSY

Appendix Procedure for maintenance

1.Remove Body

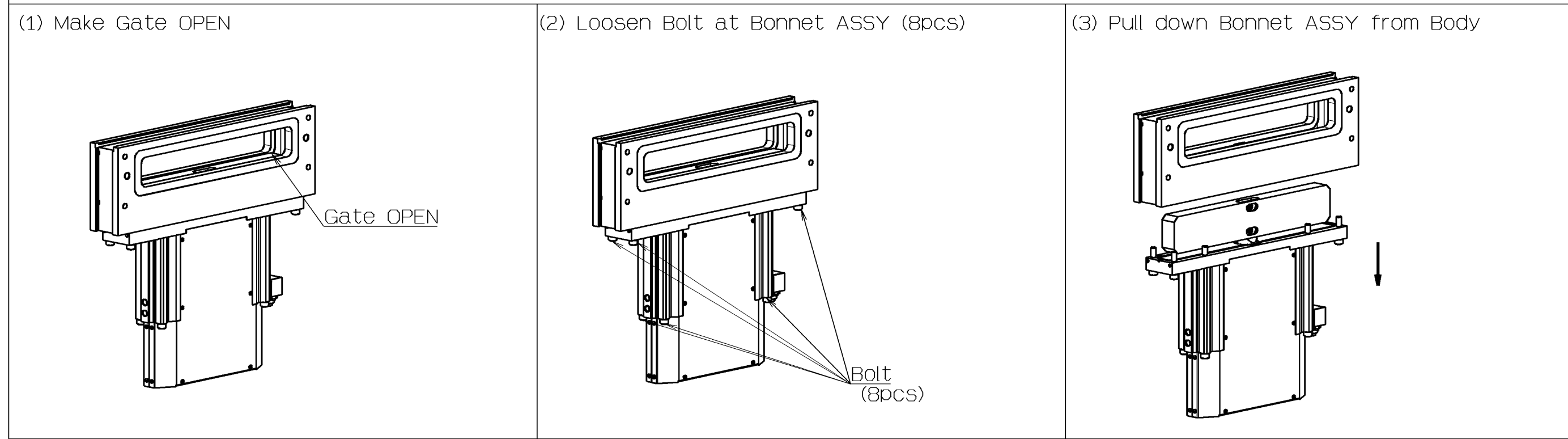

2. Remove Gate

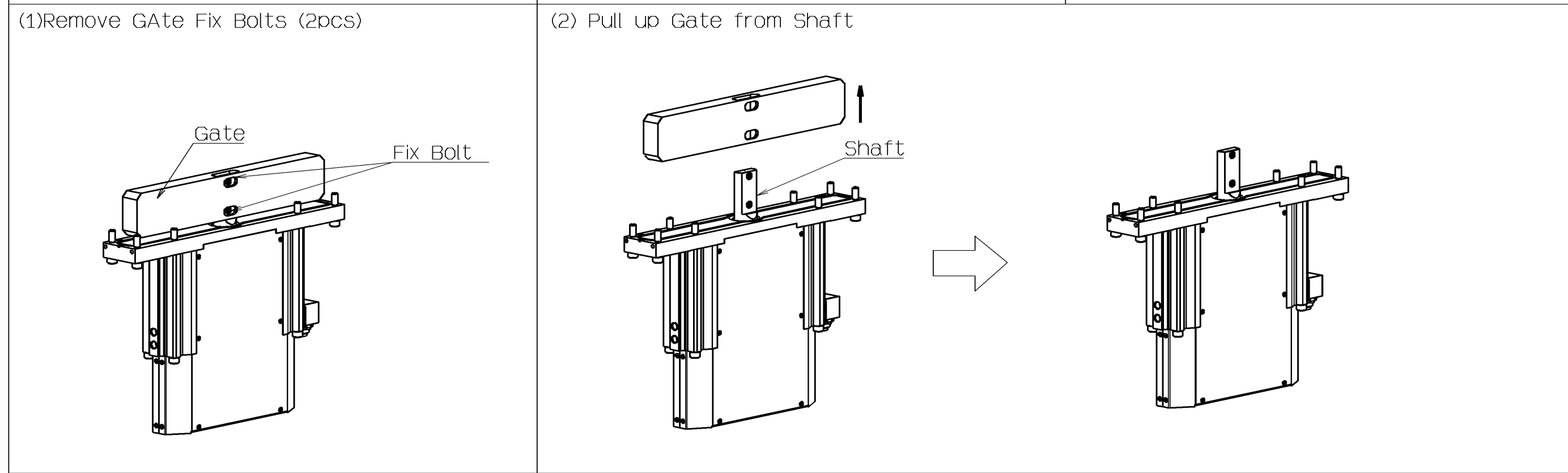

### 3. Replace Bellows ASSY

Please this Bellow replacement is implemented after "1. Remove Body" and "2. Remove Gate".

#### (1) Remove Side plate ASSY

Remove screws(8pcs) mounting Side Plate ASSY and pull down Side Plate ASSY  
 \*Please implement at OPEN and after Remove Gate and Body  
 \*Please implement after removing air piping

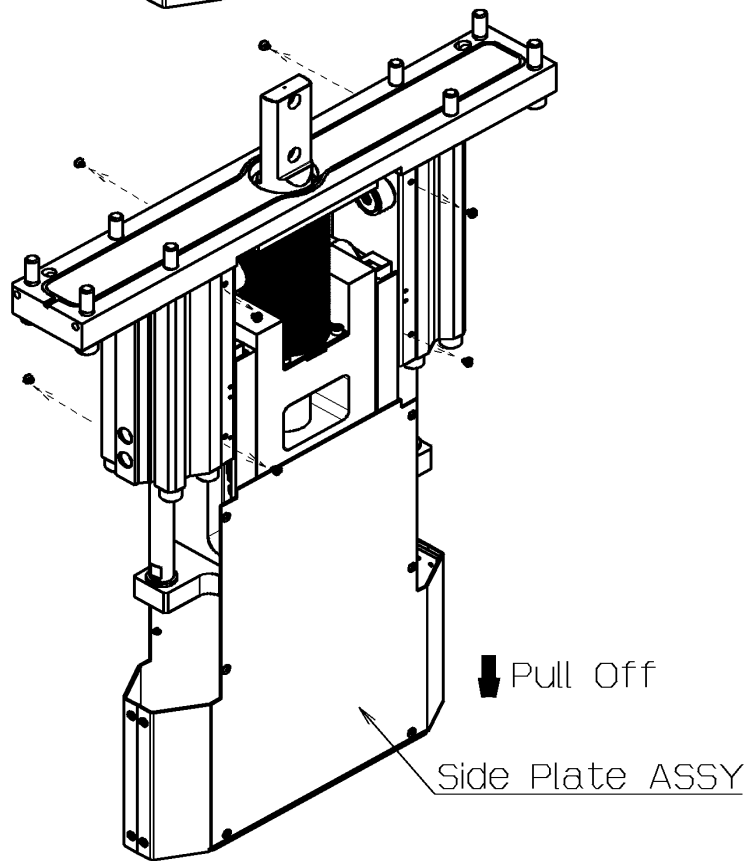
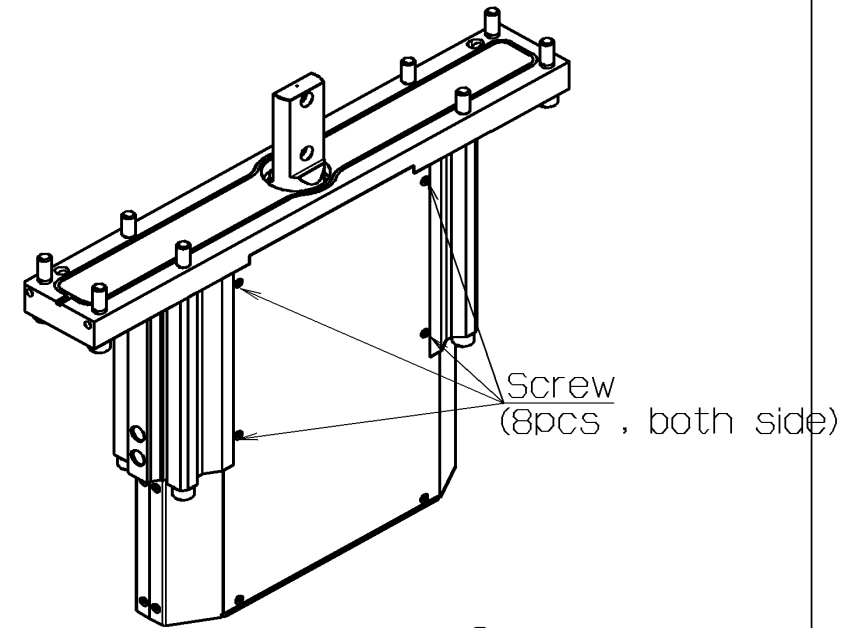

#### (2) Remove Lever ASSY

Remove Bellows clips (2pcs) and Fix bolts (2pcs) and pulling down Lever ASSY  
 \*Please use wrench to fit in width across bolt (10mm) when fix bolts are removed to avoid Piston rod's rotation  
 \*Be sure not to be lost washer and Thrust washer when Fix bolts are removed

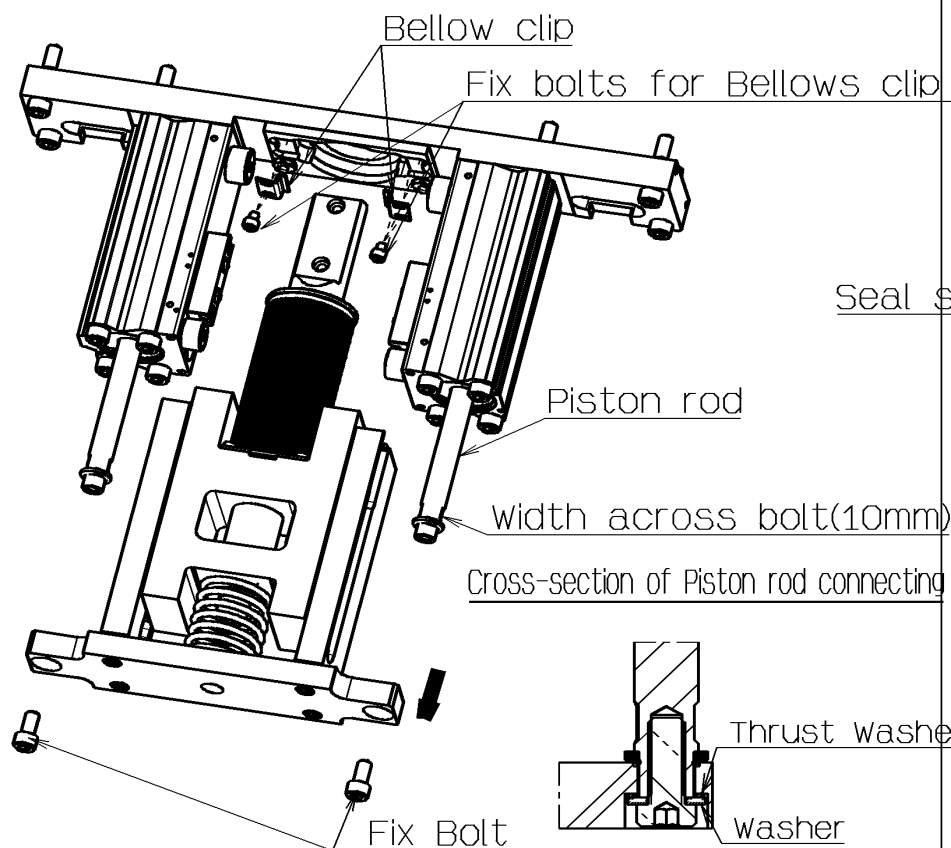
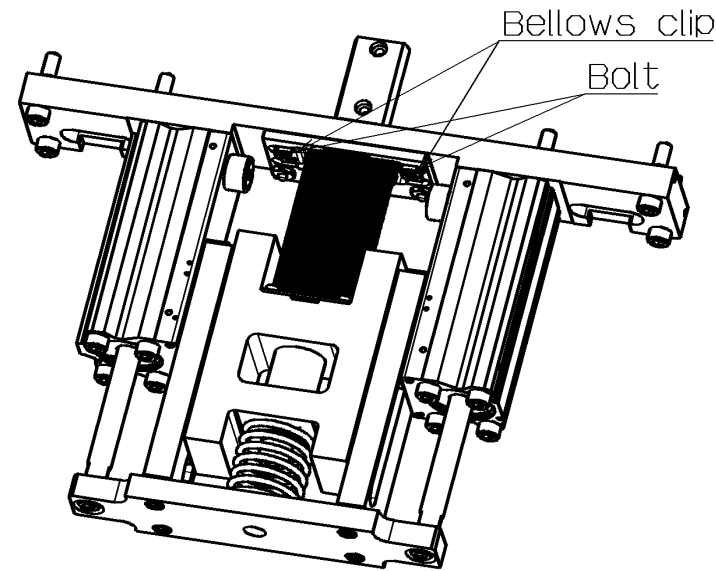

#### (3) Pull off of Bellows ASSY

Remove Bellows clamber (2pcs) on Lever ASSY pull off Bellows ASSY from Shaft  
 \*After pull off, wipe off the dust alcohol (ethanol 1 grade) in cloth (Alpha wiper: equivalent to Tex Wipe) as shown below. At this time.

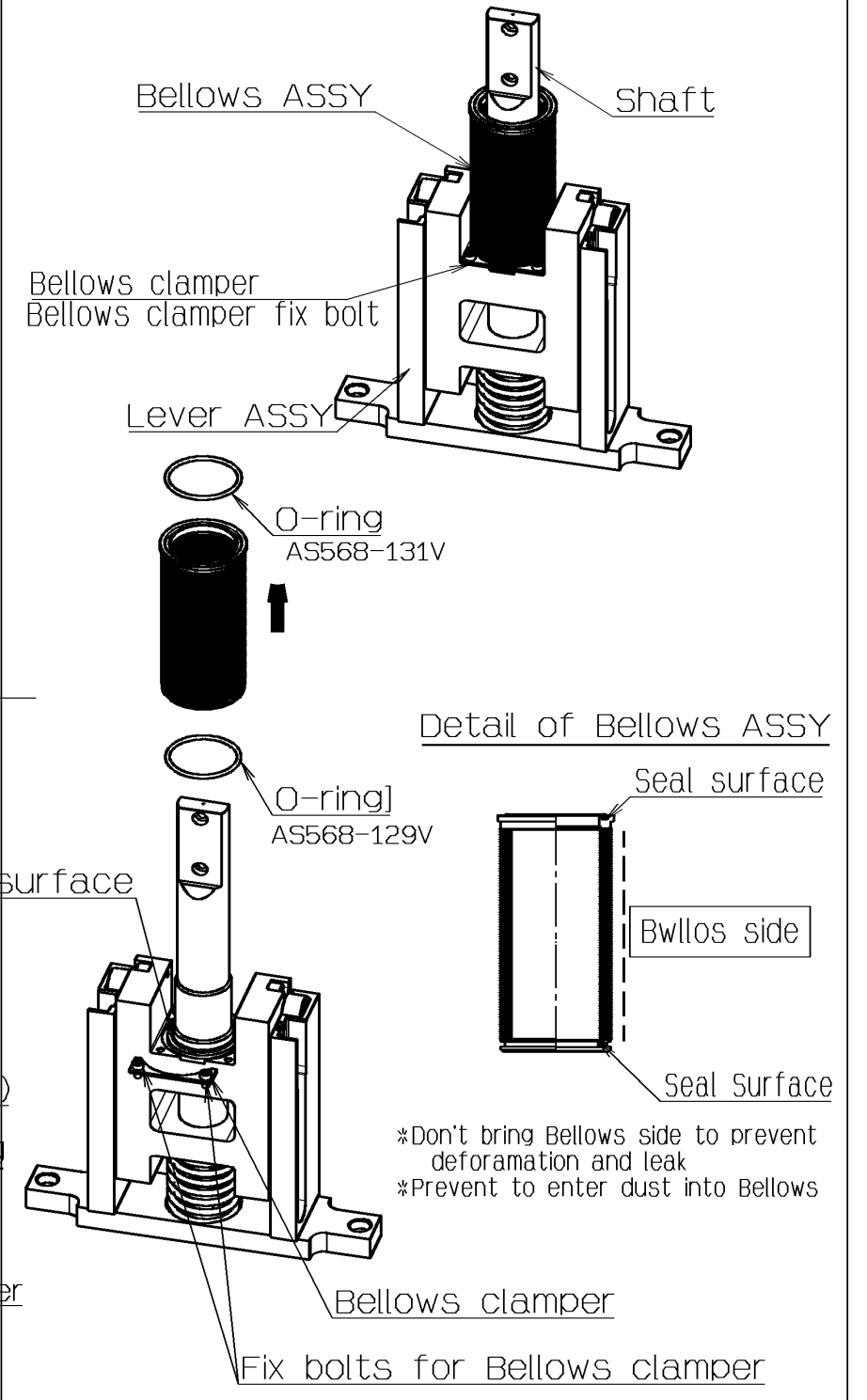

### 3. Replace Bellows

Please this Bellows replacement is implemented after "1.Remove Body" and "2.Remove Gate"

#### (4) Install Bellows ASSY

- 1) Wipe off the seal surface of Bellows ASSY and O ring with a cloth containing ethanol (grade 1). And confirm that there is no dust.
- 2) Install Bellows ASSY to Lever ASSY
- 3) Bellows Clampers (2 pcs) are installed to the groove and fix by bolts.
  - \*Be sure that Bellows clamber does not protrude from the end face of Lever
  - \*In order to suppress Bellows ASSY with equal force, tightens four bolts gradually at beginning.
  - Tightening torque:  $1.5 \pm 0.1 \text{ N} \cdot \text{m}$

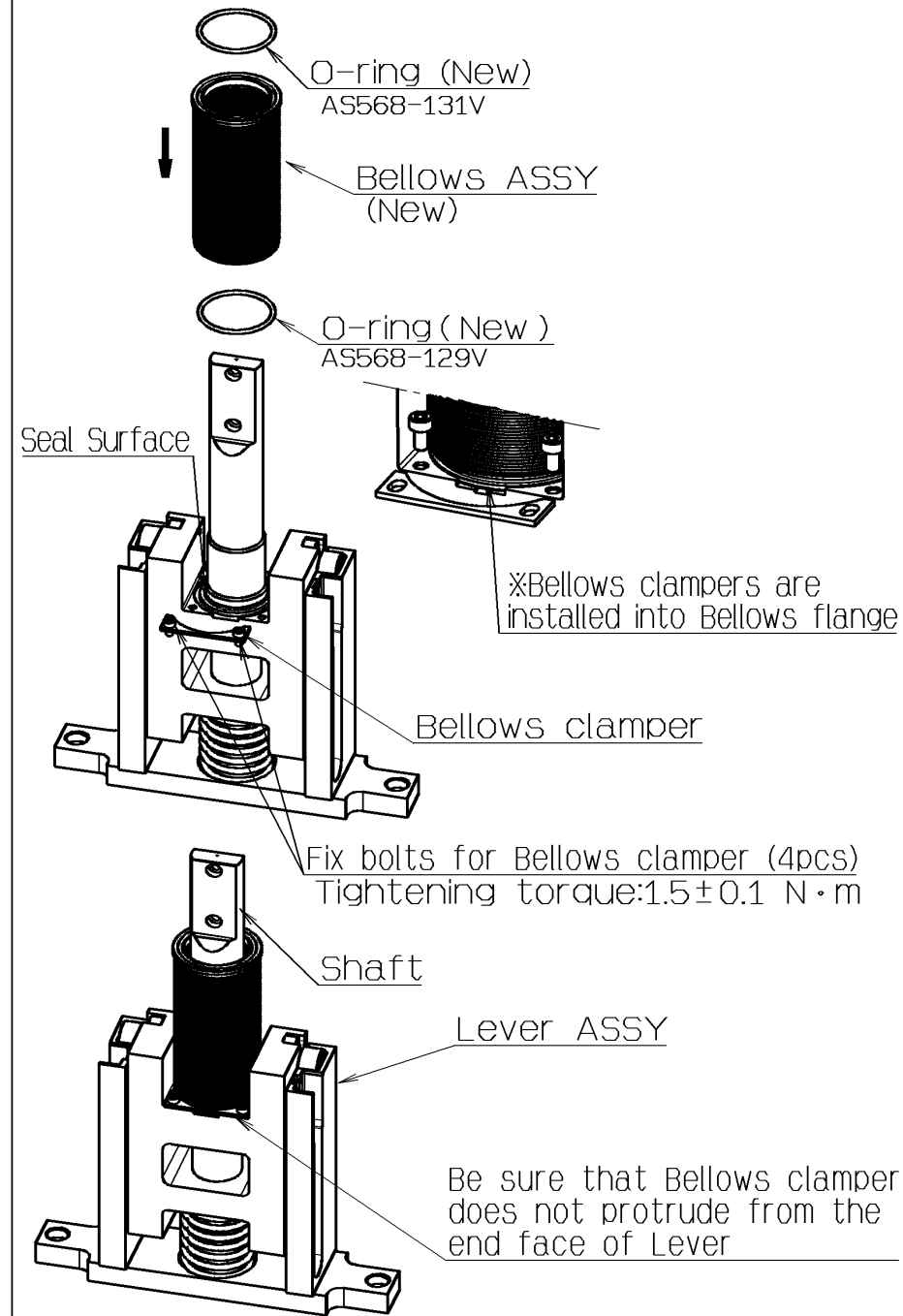

#### (5) Install Lever

- 1) Mounting Lever ASSY
  - \*Fit in Guide groove and Cam follower
  - \*Please make sure Guide Bush is not dropped
  - \*Piston rods are pulled out so that Fix bolts are fit into counter bore.
  - \*Please make sure the direction of washer and dropping O-ring
- 2) Install Bellows clip
  - \*Fix Bellows Clip and Bellows ASSY by Fix bolts.
  - \*Bellows is fit into Bonnet's dint then fix
  - \*Make sure Bellows ASSY is held at collar
  - \*Tightening torque:  $3.0 \pm 0.3 \text{ N} \cdot \text{m}$
- 3) Connecting between Lever ASSY and Piston rod
  - \*Please use wrench to fit in width across bolt (10mm) when fix bolts are tighten to avoid Piston rod's rotation
  - \*Tightening torque:  $12.5 \pm 1.2 \text{ N} \cdot \text{m}$

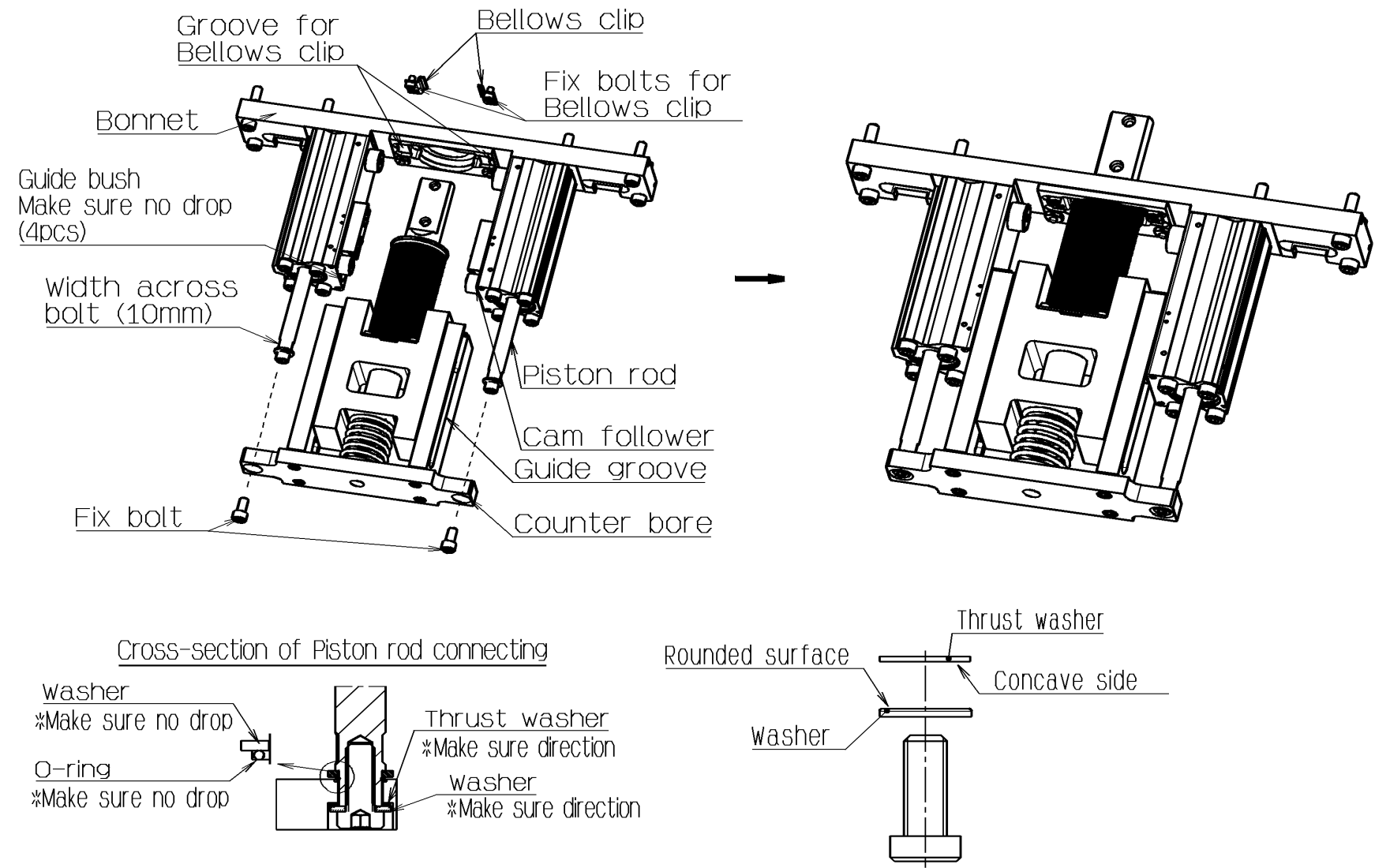

#### 4. Install side plate ASSY

Install side plate ASSY from bottom side and tighten by screws(8pcs)

\*Be sure to counter bore on Shaft and Name plate is same face

\*Install to mounting surface

\*Tightening torque:0.63N·m

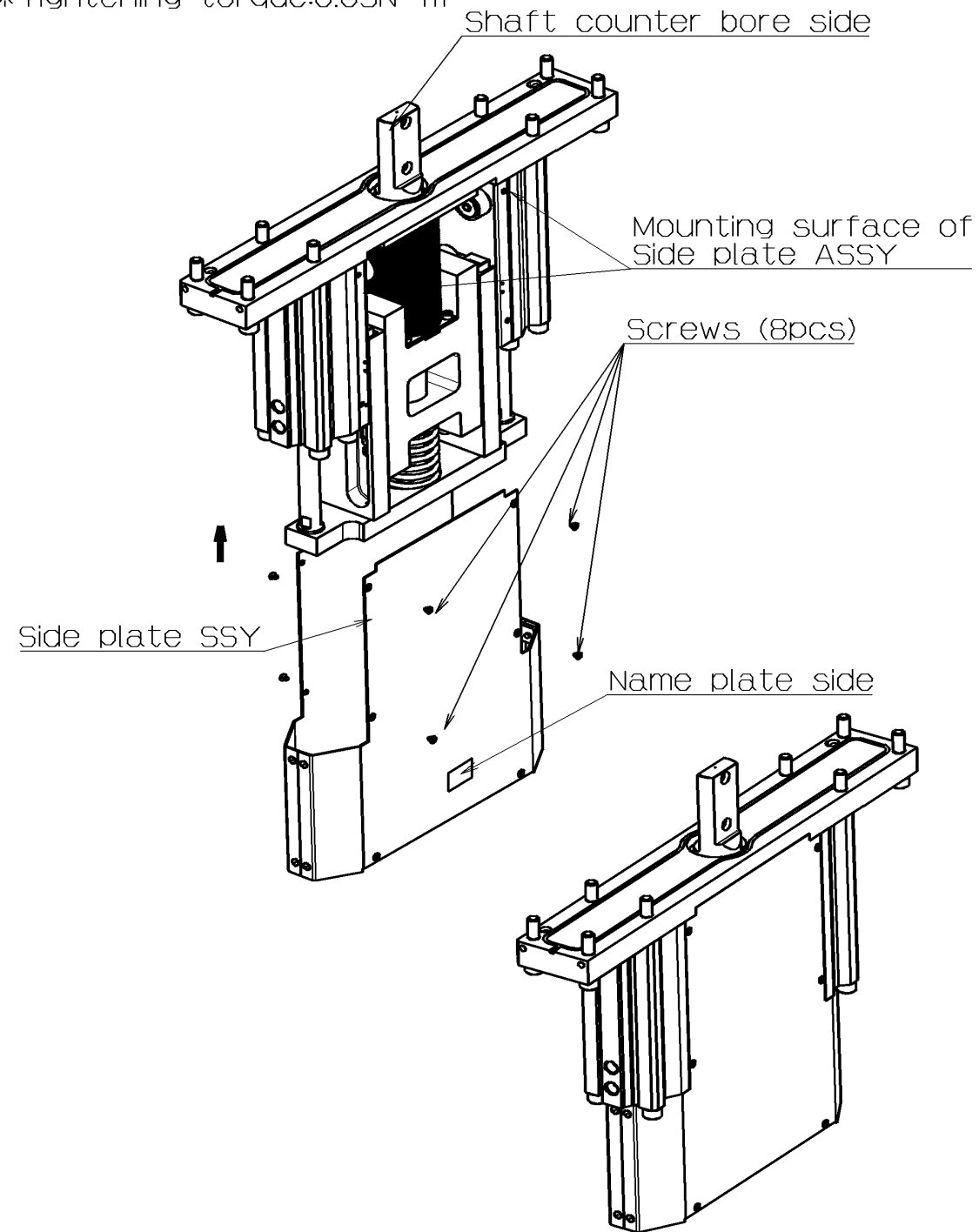

#### 5. Replace Gate O-ring

Procedure of replacing Gate O-ring

1. Remove O-ring from Gate and wipe off the dust, dirt, etc. along O ring groove by including alcohol (ethanol 1 grade) in cloth (Alpha wiper®: equivalent to Tex Wipe) as shown below.

At this time, please do not make scratches and dents to the seal surface on O-ring groove.

Note) When removing O ring, try to prevent scratches, such as using resin tweezers so as not to scratch the sheet surface of the O ring.

2. Please clean new O ring with alcohol (ethanol 1 grade) to remove dirt, dirt, etc.

3. Please confirm that there are no scratches, dirt, dirt, etc. at O ring groove on Gate.

When installing O ring into O ring groove on Gate, please install in the order of the numbers in the figure below.

When tentatively wearing up to 12 in the figure below, install the whole as finely as possible so that O-ring protrusion height of the non-mounting part becomes even.

Note) When installing O ring, please no twist the O ring (if there is a twist, you can see the parting line), and waviness.

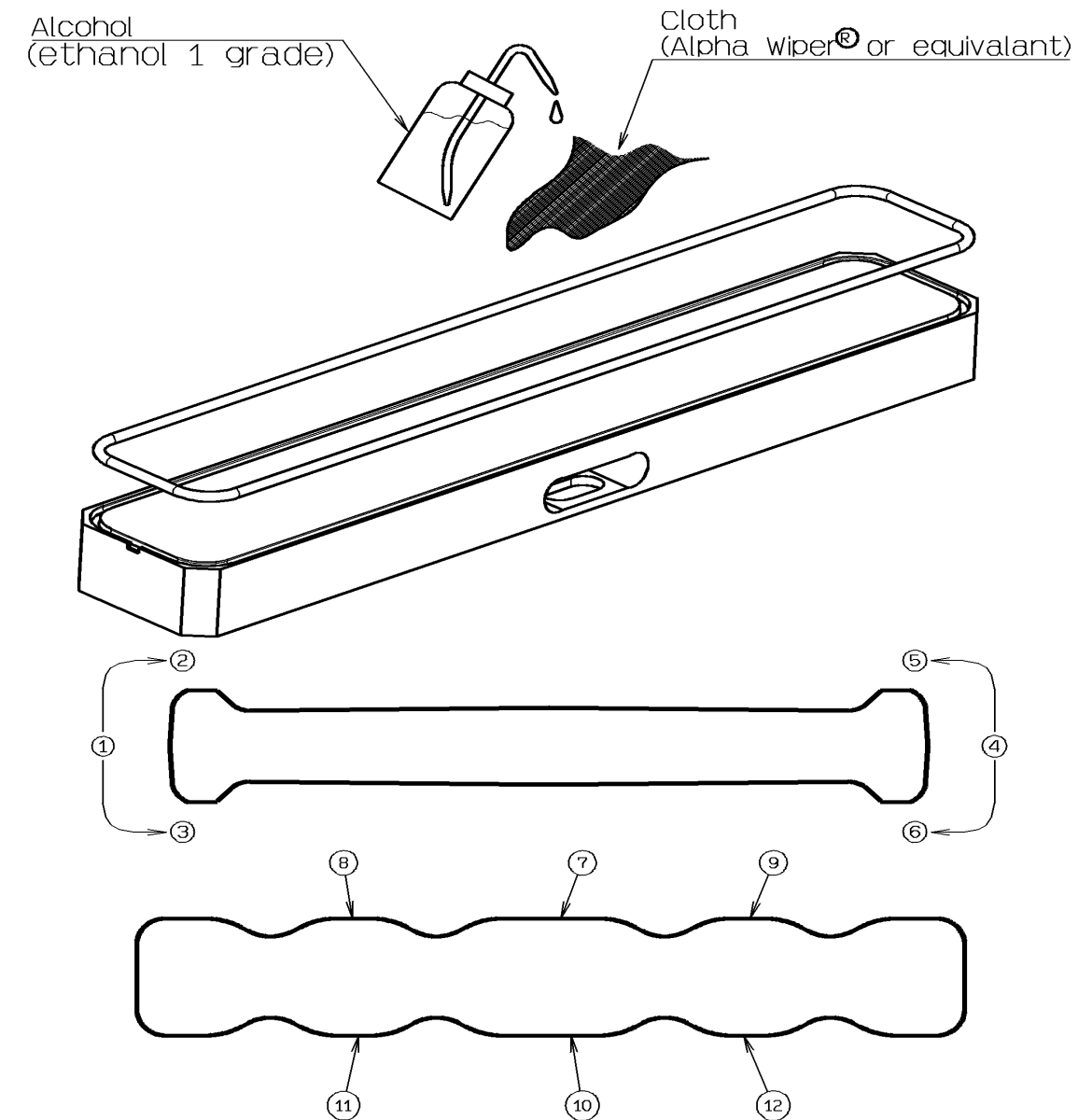



## 6. Install Gate

(1) Mounting Gate to Shaft

\*Be sure to the direction of Gate  
(Refer to groove on O-ring)

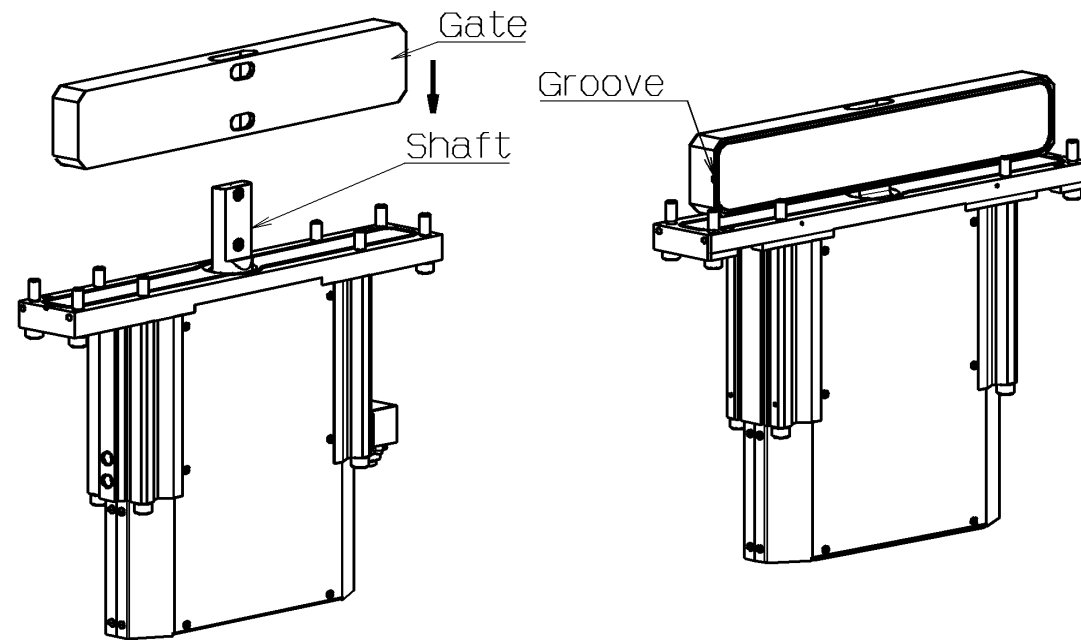

(2) Fix Gate by Fix bolts (2pcs)  
\*Tightening torque:  $3.6 \pm 0.3 \text{ N} \cdot \text{m}$

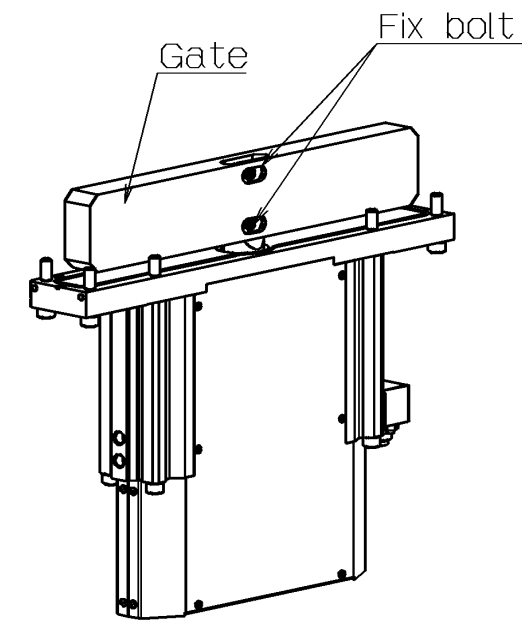

## 7. Install Body

(1) Wipe off O-ring between Body and Bonnet ASSY then  
Install Bonnet ASSY to Body

\*Please confirm O-ring is not dropped out from the groove.

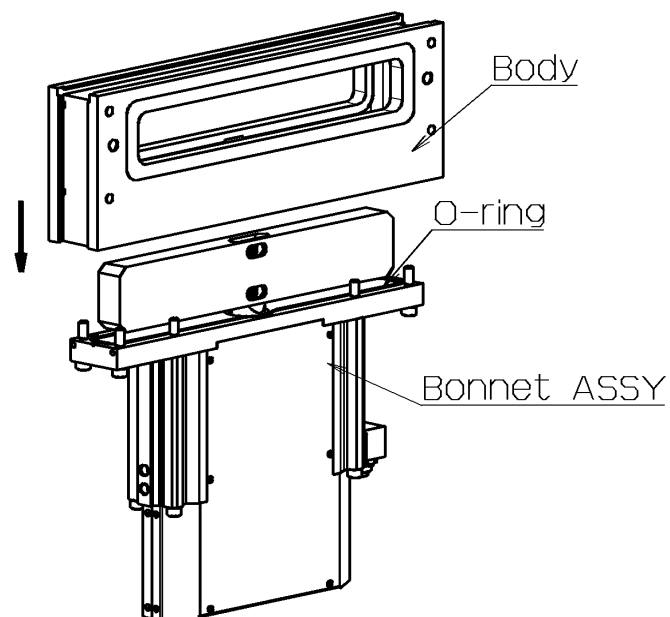

(2) Tighten Bolts (8pcs)  
\*Tightening torque:  $17.5 \pm 2 \text{ N} \cdot \text{m}$

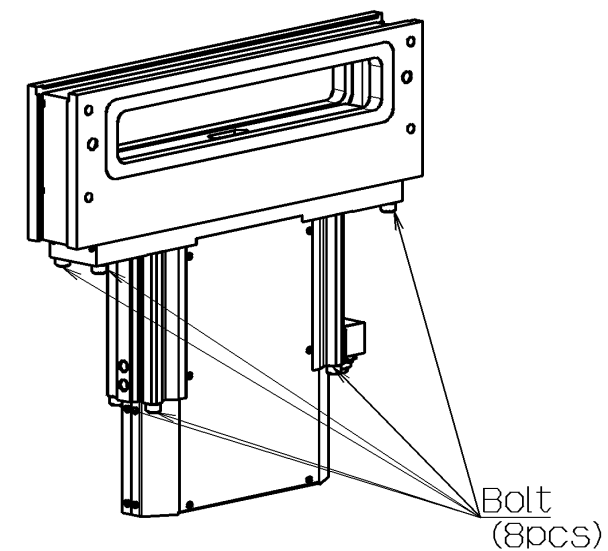

Revision history
------------------

# SMC Corporation

4-14-1, Sotokanda, Chiyoda-ku, Tokyo 101-0021 JAPAN

Tel: + 81 3 5207 8249 Fax: +81 3 5298 5362

URL <http://www.smcworld.com>

---

Note: Specifications are subject to change without prior notice and any obligation on the part of the manufacturer.

© 2011 SMC Corporation All Rights Reserved