



Operation Manual

PRODUCT NAME

SI Unit for Vacuum Manifold

MODEL / Series / Product Number

EX260-VIL1

SMC Corporation

Contents

1. Product summary	10
2. Wiring	11
2.1. Communication/Power connector	11
2.2. FE terminal	11
3. Configuration	12
3.1. IODD file	12
3.2. Direct Parameter page 1	12
3.3. IO-Link defined parameters	13
3.4. Vendor defined parameters	15
4. Process data	22
4.1. Input process data	22
4.2 Output process data	26
5. Example of energy saving operation of ejector	28
6. LED indication	29
7. Event	30
8. Specification	31
8.1. Dimensions	31
8.2. Specifications	32
9. Accessories	33
10. Troubleshooting	38



Safety Instructions

These safety instructions are intended to prevent hazardous situations and/or equipment damage. These instructions indicate the level of potential hazard with the labels of "Caution", "Warning" or "Danger". They are all important notes for safety and must be followed in addition to International Standards (ISO/IEC) *1), and other safety regulations.

*1) ISO 4414: Pneumatic fluid power -- General rules relating to systems.

ISO 4413: Hydraulic fluid power -- General rules relating to systems.

IEC 60204-1: Safety of machinery -- Electrical equipment of machines .(Part 1: General requirements)

ISO 10218: Manipulating industrial robots -Safety.

etc.



Caution

Caution indicates a hazard with a low level of risk, which if not avoided could result in minor or moderate injury.



Warning

Warning indicates a hazard with a medium level of risk, which if not avoided could result in death or serious injury.



Danger

Danger indicates a hazard with a high level of risk, which if not avoided will result in death or serious injury.

Warning

1. The compatibility of the product is the responsibility of the person who designs the equipment or decides its specifications.

Since the product specified here is used under various operating conditions, its compatibility with specific equipment must be decided by the person who designs the equipment or decides its specifications based on necessary analysis and test results.

The expected performance and safety assurance of the equipment will be the responsibility of the person who has determined its compatibility with the product.

This person should also continuously review all specifications of the product referring to its latest catalog information, with a view to giving due consideration to any possibility of equipment failure when configuring the equipment.

2. Only personnel with appropriate training should operate machinery and equipment.

The product specified here may become unsafe if handled incorrectly.

The assembly, operation and maintenance of machines or equipment including our products must be performed by an operator who is appropriately trained and experienced.

3. Do not service or attempt to remove product and machinery/equipment until safety is confirmed.

1. The inspection and maintenance of machinery/equipment should only be performed after measures to prevent falling or runaway of the driven objects have been confirmed.

2. When the product is to be removed, confirm that the safety measures as mentioned above are implemented and the power from any appropriate source is cut, and read and understand the specific product precautions of all relevant products carefully.

3. Before machinery/equipment is restarted, take measures to prevent unexpected operation and malfunction.

4. Contact SMC beforehand and take special consideration of safety measures if the product is to be used in any of the following conditions.

1. Conditions and environments outside of the given specifications, or use outdoors or in a place exposed to direct sunlight.

2. Installation on equipment in conjunction with atomic energy, railways, air navigation, space, shipping, vehicles, military, medical treatment, combustion and recreation, or equipment in contact with food and beverages, emergency stop circuits, clutch and brake circuits in press applications, safety equipment or other applications unsuitable for the standard specifications described in the product catalog.

3. An application which could have negative effects on people, property, or animals requiring special safety analysis.

4. Use in an interlock circuit, which requires the provision of double interlock for possible failure by using a mechanical protective function, and periodical checks to confirm proper operation.



Safety Instructions

Caution

1. The product is provided for use in manufacturing industries.

The product herein described is basically provided for peaceful use in manufacturing industries. If considering using the product in other industries, consult SMC beforehand and exchange specifications or a contract if necessary.
If anything is unclear, contact your nearest sales branch.

Limited warranty and Disclaimer/Compliance Requirements

The product used is subject to the following "Limited warranty and Disclaimer" and "Compliance Requirements".

Read and accept them before using the product.

Limited warranty and Disclaimer

1. The warranty period of the product is 1 year in service or 1.5 years after the product is delivered, whichever is first.*2)

Also, the product may have specified durability, running distance or replacement parts. Please consult your nearest sales branch.

2. For any failure or damage reported within the warranty period which is clearly our responsibility, a replacement product or necessary parts will be provided.

This limited warranty applies only to our product independently, and not to any other damage incurred due to the failure of the product.

3. Prior to using SMC products, please read and understand the warranty terms and disclaimers noted in the specified catalog for the particular products.

***2) Vacuum pads are excluded from this 1 year warranty.**

A vacuum pad is a consumable part, so it is warranted for a year after it is delivered.

Also, even within the warranty period, the wear of a product due to the use of the vacuum pad or failure due to the deterioration of rubber material are not covered by the limited warranty.

Compliance Requirements

1. The use of SMC products with production equipment for the manufacture of weapons of mass destruction (WMD) or any other weapon is strictly prohibited.

2. The exports of SMC products or technology from one country to another are governed by the relevant security laws and regulation of the countries involved in the transaction. Prior to the shipment of a SMC product to another country, assure that all local rules governing that export are known and followed.

Operator

- ◆ This operation manual is intended for those who have knowledge of machinery using pneumatic equipment, and have sufficient knowledge of assembly, operation and maintenance of such equipment. Only those persons are allowed to perform assembly, operation and maintenance.
- ◆ Read and understand this operation manual carefully before assembling, operating or providing maintenance to the product.

■ Safety Instructions

Warning

- Do not disassemble, modify (including changing the printed circuit board) or repair.
An injury or failure can result.
- Do not operate or set up with wet hands.
An electric shock can result.
- Do not operate the product outside of the specifications.
Do not use for flammable or harmful fluids.
Fire, malfunction, or damage to the product can result.
Verify the specifications before use.
- Do not operate in an atmosphere containing flammable or explosive gases.
Fire or an explosion can result.
This product is not designed to be explosion proof.
- If using the product in an interlocking circuit:
 - Provide a double interlocking system, for example a mechanical system.
 - Check the product regularly for proper operation.Otherwise, malfunction can result, causing an accident.
- The following instructions must be followed during maintenance:
 - Turn off the power supply.
 - Stop the air supply, exhaust the residual pressure and verify that the air is released before performing maintenance.Otherwise, an injury can result.

Caution

- When handling or assembling or replacing the unit, pay attention to the following:
 - Do not touch the sharp edges when handling the unit
 - The unit joints are tightly bound with gaskets, so do not hit your hands when replacing the unit.
 - Do not put your fingers between them when joining the units.
Otherwise, an injury can result.
- After maintenance is complete, perform appropriate functional inspections.
Stop operation if the equipment does not function properly.
Safety cannot be assured in the case of unexpected malfunction.
- Provide grounding to assure the noise resistance of the Serial System.
Individual grounding should be provided close to the product with a short cable.

NOTE

- Follow the instructions given below when designing, selecting and handling the product.
- The instructions on design and selection (installation, wiring, environment, adjustment, operation, maintenance, etc.) described below must also be followed.
 - *Product specifications
 - Use the specified voltage.
Otherwise, failure or malfunction can result.
 - Reserve a space for maintenance.
Allow sufficient space for maintenance when designing the system.
 - Do not remove any nameplates or labels.
This can lead to incorrect maintenance, or misreading of the operation manual, which could cause damage or malfunction to the product.
It may also result in non-conformity to safety standards.
 - Pay attention to the inrush current at power-up.
Depending on the connected load, the initial charge current may cause the overcurrent protection and malfunction can result.

•Product handling

*Installation

- Do not drop, hit or apply excessive shock to the fieldbus system.
Otherwise, damage to the product can result, causing malfunction.
- Tighten to the specified tightening torque.
If the tightening torque is exceeded the mounting screws may be broken.
IP65 protection cannot be guaranteed if the screws are not tightened to the specified torque.
- When carrying the vacuum manifold, make sure that the connections are not stressed.
Otherwise, the damage to connections can result. In addition, some combinations of the manifold may be very heavy, so use more than one person to carry or install the unit.
- Never mount a product in a location that will be used as a foothold.
The product may be damaged if excessive force is applied by stepping or climbing onto it.

*Wiring

- Avoid repeatedly bending or stretching the cables or placing heavy load on them.
Repetitive bending stress or tensile stress can cause breakage of the cable.
- Wire correctly.
Incorrect wiring can break the product.
- Do not perform wiring while the power is on.
Otherwise, damage to the fieldbus system and/or I/O device can result, causing malfunction.
- Do not route wires and cables together with power or high voltage cables.
Otherwise, the fieldbus system and/or I/O device can malfunction due to interference of noise and surge voltage from power and high voltage cables to the signal line.
Route the wires (piping) of the fieldbus system and/or I/O device separately from power or high voltage cables.
- Confirm proper insulation of wiring.
Poor insulation (interference from another circuit, poor insulation between terminals, etc.) can lead to excess voltage or current being applied to the product, causing damage.
- Take appropriate measures against noise, such as using a noise filter, when the fieldbus system is incorporated into equipment.
Otherwise, noise can cause malfunction.

*Environment

- Select the proper type of protection according to the environment of operation.
IP65 protection is achieved when the following conditions are met.
 - (1) The power/communication connector on the SI Unit is properly connected to the cable with M12 connector.
 - (2) Suitable mounting is carried out between the SI Unit and the vacuum manifold.
 - (3) Unused connector is fitted with a seal cap.
If using in an environment that is exposed to water splashes, please take measures such as using a cover.
- Do not use in a place where the product could be splashed by oil or chemicals.
If the product is to be used in an environment containing oils or chemicals such as coolant or cleaning solvent, even for a short time, it may be adversely affected (damage, malfunction etc.).
- Do not use the product in an environment where corrosive gases or fluids could be splashed.
Otherwise, damage to the product and malfunction can result.
- Do not use in an area where surges are generated.
If there is equipment that generates a large amount of surge (solenoid type lifter, high frequency induction furnace, motor, etc.) close to the fieldbus system, this may cause deterioration or breakage of the internal circuit of the fieldbus system. Avoid sources of surge generation and crossed lines.
- When a surge-generating load such as a relay or solenoid is driven directly, use a fieldbus system with a built-in surge-absorbing element.
Direct drive of a load generating surge voltage can damage the fieldbus system.
- The product is CE marked, but not immune to lightning strikes. Take measures against lightning strikes in the system.
- Prevent foreign matter such as remnant of wires from entering the fieldbus system to avoid failure and malfunction.

- Mount the product in a place that is not exposed to vibration or impact.
Otherwise, failure or malfunction can result.
- Do not use the product in an environment that is exposed to temperature cycle.
Heat cycles other than ordinary changes in temperature can adversely affect the inside of the product.
- Do not expose the product to direct sunlight.
If using in a location directly exposed to sunlight, shade the product from the sunlight.
Otherwise, failure or malfunction can result.
- Keep within the specified ambient temperature range.
Otherwise, malfunction can result.
- Do not operate close to a heat source, or in a location exposed to radiant heat.
Otherwise, malfunction can result.

***Adjustment and Operation**

- Perform settings suitable for the operating conditions.
Incorrect setting can cause operation failure.
- Please refer to the PLC manufacturer's manual etc. for details of programming and addresses.
For the PLC protocol and programming refer to the relevant manufacturer's documentation.

***Maintenance**

- Turn off the power supply, stop the supplied air, exhaust the residual pressure and verify the release of air before performing maintenance.
There is a risk of unexpected malfunction.
- Perform regular maintenance and inspections.
There is a risk of unexpected malfunction.
- After maintenance is complete, perform appropriate functional inspections.
Stop operation if the equipment does not function properly.
Otherwise, safety is not assured due to an unexpected malfunction or incorrect operation.
- Do not use solvents such as benzene, thinner etc. to clean each unit.
They could damage the surface of the body and erase the markings on the body.
Use a soft cloth to remove stains.
For heavy stains, use a cloth soaked with diluted neutral detergent and fully squeezed, then wipe up the stains again with a dry cloth.

Fieldbus System/ Industrial IoT Cybersecurity

In recent years, factories have introduced industrial IoT, building up complex networks of production machines. These systems may be subject to a new threat, cyberattack. To protect the industrial IoT from cyberattacks, it is important to take multiple measures (multi-layer protection) for IoT devices, networks and clouds.

For this purpose, SMC recommends that the following measures are always taken into consideration. For further details of the following measures, please see security information published by your local country security agencies.

1. Do not connect the devices via a public network.

- If you unavoidably need to access the device or cloud via a public network, ensure to use a secure, private network such as VPN.
- Do not connect an office IT network and factory IoT network.

2. Build a firewall to prevent a threat from entering the device and system.

- Set up a router or firewall at network boundaries to allow minimum required communications.
- Disconnect from the network or turn off the device if no continuous connection is required.

3. Physically block an access to unused communication ports or disable them.

- Inspect regularly each port if any unnecessary device is connected to the network system.
- Operate necessary services (SSH, FTP, SFTP, etc.) only.
- Set a transmission range of the device using a wireless LAN or other radio system to the minimum required and use only devices approved according to the radio act in the country concerned.
- Install a device generating radio waves in such place as there is no interference from indoor or outdoor.

4. Set up a secure communication method such as data encryption.

- Encrypt data in every environment, including IoT networks, secure gate-way connections, for secure communications.

5. Grant access permissions by user accounts and limit the number of users.

- Regularly review accounts and delete all unused accounts or permissions.
- Establish an account lockout system to block an access to the account for a certain period if log-in fails more than the given threshold.

6. Protect passwords.

- Change the default password when you first use the device or system.
- Choose a long password (minimum 8 characters) using a mix of different letters and characters to make the password more secure and harder to hack.

7. Use the latest security software.

- Install antivirus software on all computers to detect and remove viruses.
- Keep the antivirus software up to date.

8. Use the latest version of the device and system software.

- Apply patches to keep the OS and applications up to date.

9. Monitor and detect abnormalities in the network.

- Keep monitoring the network for any abnormalities to take a prompt measure and issue an alert if any abnormality is detected. Install an intrusion detection system (IDS) and intrusion prevention system (IPS).

10. Delete data from devices when disposed of.

- Before disposing of any IoT devices, delete stored data or physically destruct media to prevent any misuse of the data.

1. Product summary

This document is an operation manual for a SI (Serial Interface) Unit which controls vacuum (ejector) manifold (ZKJ series). The SI Unit is a IO-Link device. The SI Unit controls a vacuum manifold which has 16 supply valves max., 16 release valves max. and 16 pressure sensors max..

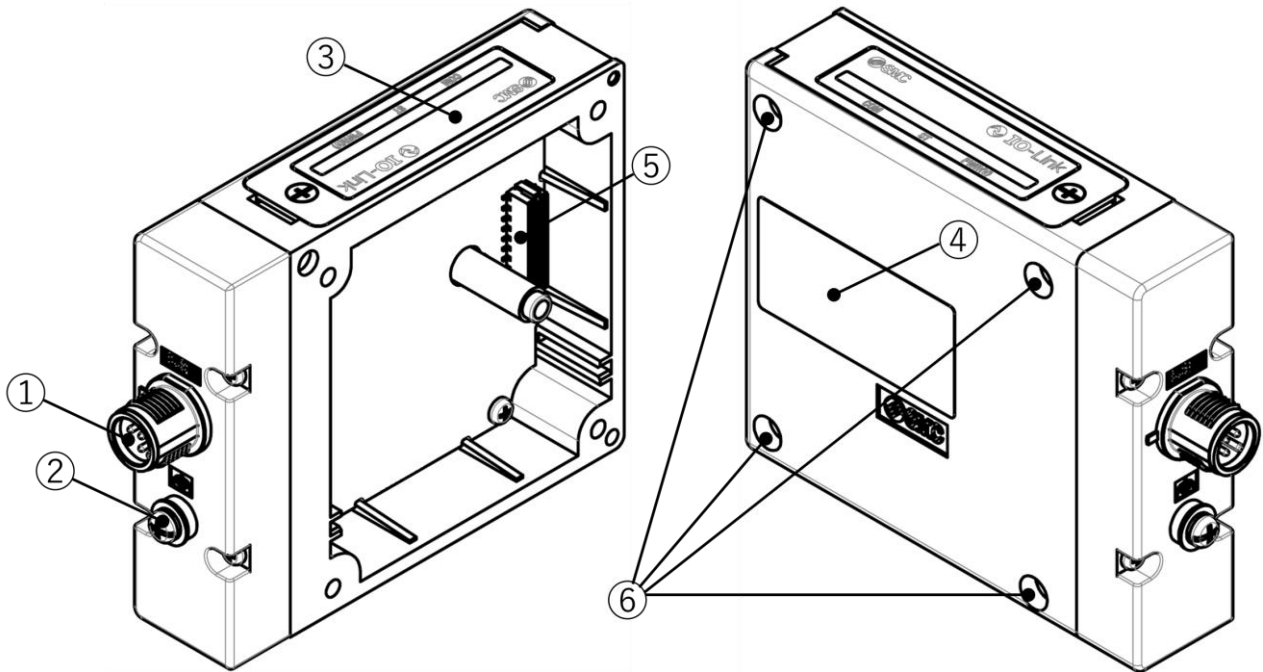

No.	Item	Description
1	Communication/Power connector	Connector for IO-Link communication and supplying power to the SI Unit, pressure sensors and valves. (M12 5 pin plug A-coded) Refer to Section 2.1 .
2	FE terminal	Functional earth. (M3 screw) Refer to Section 2.2 .
3	LED display	LED display to indicate the status of the SI Unit. Refer to Section 6 .
4	Product information label	Information label to indicate SI Unit details such as serial No. etc..
5	Connector	Communication connection to vacuum manifold.
6	Mounting holes	Connects to vacuum manifold.

Fig 1-1. The SI Unit structure

For further details on mounting, installation, etc. of the vacuum manifold, refer to the vacuum manifold operation manual.

Warning

The SI unit must be connected to a vacuum manifold before it is powered ON.

2. Wiring

Select the appropriate cables to mate with the connectors mounted on the SI Unit, refer to [Section 9](#).

2.1. Communication/Power connector (IO-Link Port Class B)

BUS IN : M12 5 pin plug A-coded

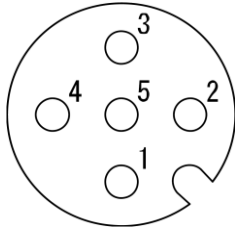

Pin No.	Designation	Content
1	L+	+24 V for logic/input
2	P24	+24 V for output
3	L-	0 V for logic/input
4	C/Q	IO-Link communication data
5	N24	0 V for output

Fig 2-1. Pin allocation of M12 5 pins plug A-coded connector

The power supply for logic/input and the power supply for output are isolated.

2.2. FE terminal

The SI Unit must be connected to FE (Functional Earth) to divert electromagnetic interference. For maximum protection, the FE cable should be as thick and short as reasonably possible. The FE terminal and the metal parts of the fieldbus interface/power supply connector are internally connected.

FE terminal screw tightening torque : 0.3 Nm.

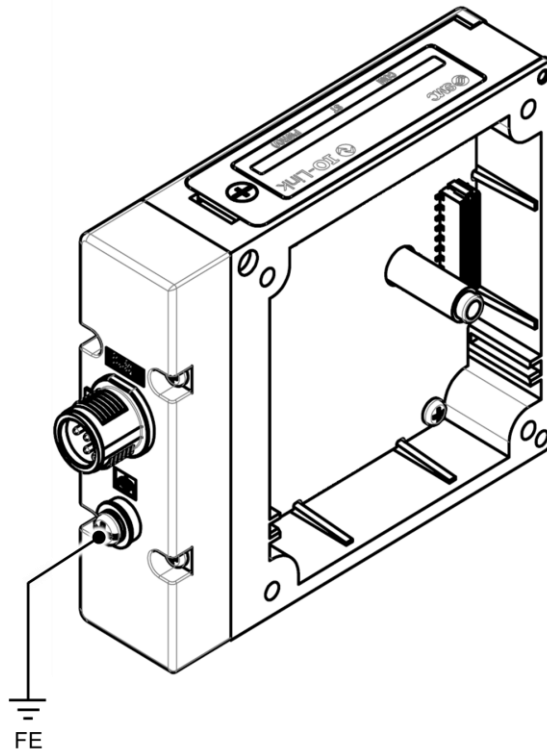

Fig 2-2. FE terminal

3. Configuration

3.1. IODD file

An IODD (IO Device Description) file is a profile held by an IO-Link device, which contains device specific information such as process data, parameter and default values, vendor name and product name etc. The content of the IODD file description is defined as the IO-Link specification. The IODD file is supplied with a set of image files e.g., vendor logo, device photo and device icon. The IODD file of the SI Unit is as follows.

Table 3-1. IODD file

IODD file	Vacuum manifold stations	Process data sizes	
		input	output
SMC-EX260-VIL1_4-yyyyymmdd-IODD1.1	4	4 byte	2 byte
SMC-EX260-VIL1_8-yyyyymmdd-IODD1.1	8	5 byte	3 byte
SMC-EX260-VIL1_12-yyyyymmdd-IODD1.1	12	6 byte	4 byte
SMC-EX260-VIL1_16-yyyyymmdd-IODD1.1	16	7 byte	5 byte

Note

- "yyyyymmdd" represents the date IODD file was created, "yyyy" is the year, "mm" is the month and "dd" is the date.

3.2. Direct Parameter page 1

Table 3-2. Direct Parameter page 1

Address	Content	Access	Value/Description/Remark
0x00	MasterCommand	W	---
0x01	MasterCycleTime	R/W	Based on the MinCycleTime value, this value is set by the IO-Link master when OPERATE state. The default value is 0xBF (132.8ms).
0x02	MinCycleTime	R	Refer to Section 3.2.1 .
0x03	M-SequenceCapability	R	Fixed at 0x29. -PREOPERATE M-Sequence type : TYPE_1_V -OPERATE M-Sequence type : TYPE_2_V -ISDU supported
0x04	RevisionID	R	Fixed at 0x11.
0x05	ProcessDataIn	R	Refer to Section 3.2.1 .
0x06	ProcessDataOut	R	
0x07	VendorID 1 (MSB)	R	Fixed at 0x0083.
0x08	VendorID 2 (LSB)		
0x09	DeviceID 1 (Octet 2, MSB)	R	Refer to Section 3.2.1 .
0x0A	DeviceID 2 (Octet 1)		
0x0B	DeviceID 3 (Octet 0, LSB)		
0x0C	FunctionID 1 (MSB)	R	Fixed at 0x0000.
0x0D	FunctionID 2 (LSB)		
0x0E	Reserved	R	Fixed at 0x00.

Note

- For the access type, "R" means Read and "W" means Write.

3.2.1. MinCycleTime, ProcessDataIn/Out, Device ID

Table 3-3. MinCycleTime, ProcessDataIn/Out, Device ID

Vacuum manifold stations	MinCycleTime (Address : 0x02)	ProcessDataIn (Adress : 0x05)	ProcessDataOut (Address : 0x06)	Device ID (Adress : 0x09...0x0B)
4	0x28 (4.0 ms)	0x83 (4 byte)	0x10 (2 byte)	0x000254
8	0x2E (4.6 ms)	0x84 (5 byte)	0x82 (3 byte)	0x000255
12	0x34 (5.2 ms)	0x85 (6 byte)	0x83 (4 byte)	0x000256
16	0x3A (5.8 ms)	0x86 (7 byte)	0x84 (5 byte)	0x000257

3.3. IO-Link defined parameters

Table 3-4. IO-Link defined parameters

Index(dec)	Parameter	Access	Value/Description/Remark
0x0002(2)	SystemCommand	W	Refer to Section 3.3.1.
0x0003(3)	DataStorageIndex	R/W	---
0x0010(16)	VendorName	R	SMC Corporation
0x0011(17)	VendorText	R	www.smcworld.com
0x0012(18)	ProductName	R	Vacuum manifold 4 stations : EX260-VIL1_4_ejectors Vacuum manifold 8 stations : EX260-VIL1_8_ejectors Vacuum manifold 12 stations : EX260-VIL1_12_ejectors Vacuum manifold 16 stations : EX260-VIL1_16_ejectors
0x0013(19)	ProductID	R	EX260-VIL1
0x0014(20)	ProductText	R	Vacuum Manifold
0x0015(21)	SerialNumber	R	**...*(16 characters max.)
0x0016(22)	HardwareRevision	R	V*.*
0x0017(23)	FirmwareRevision	R	V*.*.*
0x0018(24)	ApplicationSpecificTag	R/W	Default value : **...*(32 characters) Can be set to 16-32 characters.
0x0024(36)	DeviceStatus	R	Refer to Section 3.3.2.
0x0025(37)	DetailedDeviceStatus	R	Refer to Section 3.3.3.

3.3.1. SystemCommand (Index 2)

The various reset commands supported by the SI Unit are as follows.

Table 3-5. SystemCommand

Value	Command	Description/Remark
0x80	Device reset	The SI Unit restarts with the power on.
0x81	Application reset	Reset vendor defined parameter to default values while maintaining IO-Link communication.
0x83	Back-to-box	Reset vendor defined parameter to default values and disable IO-Link communication. IO-Link communications can be restored by restarting the SI Unit.

3.3.2. DeviceStatus (Index 36)

Table 3-6. DeviceStatus

Subindex	Value	Definition	Content
0	0	Device is operating properly	Operating normally.
	1	Maintenance-Required	<ul style="list-style-type: none"> Power supply for logic/input is low. (< approx. 16.8 VDC) The setting of Supply valve type parameter has a mismatch. The setting of Pressure/Hysteresis parameter has a failure. Valve protection function is operating.
	2	Out-of-Specification	(Not applicable for this product.)
	3	Functional-Check	(Not applicable for this product.)
	4	Failure	<ul style="list-style-type: none"> Valve has a short circuit. Pressure sensor has a short circuit. Pressure sensor has a failure or a disconnection. No connection or a disconnection between the SI Unit and vacuum manifold. There is a firmware error.

3.3.3. DetailedDeviceStatus (Index 37)

Table 3-7. DetailedDeviceStatus

Sub index	Size	Content	EventQualifier (byte 0)					Event Code (byte 1-2)
			Value	MODE bit 6-7	TYPE bit 4-5	SOURCE bit 3	INSTANCE bit 0-2	
1	3 byte	Device hardware failure	0xF4	11b (3) (Event appears)	11b (3) (Error)	0 (Device)	100b (4) (Application)	0x5000
2		Non volatile memory failure						0x5011
3		Valve short circuit						0x1800
4		Pressure sensor short circuit						0x1801
5		Pressure sensor failure/disconnection						0x1802
6		Vacuum manifold no connection						0x1803
7		Vacuum manifold disconnection						0x1804
8		Firmware error						0x1805
9		Voltage drop of power supply for logic/input	0xE4	11b (3) (Event appears)	10b (2) (Warning)	0 (Device)	100b (4) (Application)	0x5111
10		Supply valve type parameter mismatch						0x1850
11		Pressure/Hysteresis parameter setting failure						0x1851
12		Valve protection						0x1852

Note

- DetailedDeviceStatus can only be accessed by Subindex 0, which allows all diagnostic information to be read at once. (3 byte x 12 contents = 36 byte)

3.4. Vendor defined parameters

Tale 3-8. Vendor defined parameters

Index(dec)	Subindex	Access	Parameter name	Size[byte]	Data Storage	Section
0x0040(64)	1...16	R/W	Pressure P1	2	Y	3.4.1
0x0041(65)	1...16	R/W	Hysteresis H1	2	Y	3.4.2
0x0042(66)	1...16	R/W	Pressure P2	2	Y	3.4.3
0x0043(67)	1...16	R/W	Hysteresis H2	2	Y	3.4.4
0x0044(68)	1...16	R/W	Pressure P3	2	Y	3.4.5
0x0045(69)	1...16	R/W	Hysteresis H3	2	Y	3.4.6
0x0046(70)	1...16	R/W	Pressure sensor use	1	Y	3.4.7
0x0047(71)	1...16	R/W	Supply valve type	1	Y	3.4.8
0x0048(72)	1...16	R/W	Energy saving function	1	Y	3.4.9
0x0049(73)	1...16	R/W	Pressure range	1	Y	3.4.10
0x004A(74)	1...16	R/W	Valve protection count	1	Y	3.4.11
0x0055(85)	1...16	R	Current pressure value	2	N	3.4.12
0x0056(86)	1...16	R	Valve short circuit status	1	N	3.4.13
0x0057(87)	1...16	R	Pressure sensor failure/disconnection status	1	N	3.4.14
0x0058(88)	1...16	R	Valve protection status	1	N	3.4.15
0x0059(89)	1...16	R	Supply valve type status	1	N	3.4.16
0x005A(90)	1...16	R	Pressure/Hysteresis parameter failure status	1	N	3.4.17
0x005B(91)	0	R	Receive error count	4	N	3.4.18
0x0091(145)	0	W	Zero clear	1	N	3.4.19
0x0092(146)	0	W	Valve protection release	1	N	3.4.20

Note

- "Y" means included in DataStorage, "N" means not included in DataStorage.
- Parameter settings should be carried out with all ejector CHs in the following state :
 - Supply valves closed (vacuum instruction OFF)
 - Release valves closed (release instruction OFF)
 - Atmospheric open state with no pressure applied in the ejector
 Refer to [Section 4.2.2](#).
- For parameters of Index 64...74, 85...90 :
 - Parameter for each ejector CHs can be access individually by specifying the relevant Subindex. i.e., CH0 parameters are accessed via Subindex 1, CH1 via Subindex 2 etc.
 - Subindex 0 can be used to access all CH parameters at once.
 - i.e., disables the energy saving function for all CHs by writing 0 to Index 72 and Subindex 0.

3.4.1. Pressure P1 (Index 64)

Table 3-9. Pressure P1

Sub index	Size [byte]	Access	Default (dec)	Content	Description
1	2	R/W	0x0258 (600)	Vacuum confirmation threshold (P1) of CH0	Set vacuum confirmation threshold (P1) for each CH. Refer to Section 5 . Settable range : 11...989 (-1.1 kPa...-98.9 kPa) Combination conditions with other parameters : H1+1 ≤ P1 ≤ P2-H2
...	
16	2	R/W	0x0258 (600)	Vacuum confirmation threshold (P1) of CH15	

3.4.2. Hysteresis H1 (Index 65)

Table 3-10. Hysteresis H1

Sub index	Size [byte]	Access	Default (dec)	Content	Description
1	2	R/W	0x0032 (50)	Vacuum confirmation hysteresis (H1) of CH0	Set vacuum confirmation hysteresis (H1) for each CH. Refer to Section 5 . Settable range : 10...988 (1.0 kPa...98.8 kPa) Combination conditions with other parameters : 10 ≤ H1 ≤ P1-1
...	
16	2	R/W	0x0032 (50)	Vacuum confirmation hysteresis (H1) of CH15	

3.4.3. Pressure P2 (Index 66)

Table 3-11. Pressure P2

Sub index	Size [byte]	Access	Default (dec)	Content	Description
1	2	R/W	0x02EE (750)	Energy saving operation threshold (P2) of CH0	Set energy saving operation threshold (P2) for each CH. Refer to Section 5 . Settable range : 21...999 (-2.1 kPa...-99.9 kPa) Combination conditions with other parameters : P1+H2 ≤ P1 ≤ 999
...	
16	2	R/W	0x02EE (750)	Energy saving operation threshold (P2) of CH15	

3.4.4. Hysteresis H2 (Index 67)

Table 3-12. Hysteresis H2

Sub index	Size [byte]	Access	Default (dec)	Content	Description
1	2	R/W	0x0064 (100)	Energy saving operation hysteresis (H2) of CH0	Set energy saving operation hysteresis (H2) for each CH. Refer to Section 5 . Settable range : 10...988 (1.0 kPa...98.8 kPa) Combination conditions with other parameters : 10 ≤ H2 ≤ P2-P1
...	
16	2	R/W	0x0064 (100)	Energy saving operation hysteresis (H2) of CH15	

3.4.5. Pressure P3 (Index 68)

Table 3-13. Pressure P3

Sub index	Size [byte]	Access	Default (dec)	Content	Description
1	2	R/W	0x0028 (40)	Release confirmation threshold (P3) of CH0	Set release confirmation threshold (P3) for each CH. Refer to Section 5 . Settable range : 31...2000 (3.1 kPa...200.0 kPa) Combination conditions with other parameters : H3+1 ≤ P3 ≤ 2000
...	
16	2	R/W	0x0028 (40)	Release confirmation threshold (P3) of CH15	

3.4.6. Hysteresis H3 (Index 69)

Table 3-14. Hysteresis H3

Sub index	Size [byte]	Access	Default (dec)	Content	Description
1	2	R/W	0x000A (10)	Release confirmation hysteresis (H3) of CH0	Set release confirmation hysteresis (H3) for each CH. Refer to Section 5 . Settable range : 10...1999 (1.0 kPa...199.9 kPa) Combination conditions with other parameters : 10 ≤ H3 ≤ P3-1
...	
16	2	R/W	0x000A (10)	Release confirmation hysteresis (H3) of CH15	

Note

- At Pressure P1/P2, set the negative pressure (vacuum pressure) in units of -0.1 kPa.
- At Pressure P3, set the positive pressure in units of -0.1 kPa.
- If any of the combination conditions are not met after setting Pressure * or Hysteresis * parameters, the vacuum/release instructions for all CHs will be disabled (valve power OFF) and diagnostic information will be issued. Refer to [Section 3.4.17](#) and [Section 7](#).

3.4.7. Pressure sensor use (Index 70)

Table 3-15. Pressure sensor use

Sub index	Size [byte]	Access	Default	Content	Description
1	1	R/W	0x01	Pressure sensor used/unused of CH0	Set pressure sensor used/unused for each CH. When set to Unused : - Pressure value of relevant CH is fixed at 0x8000 - Pressure sensor failure/disconnection status (Section 3.4.14) of relevant CH is invalid 0x00 : Unused 0x01 : Used
...	
16	1	R/W	0x01	Pressure sensor used/unused of CH15	

Note

- If vacuum manifold contains blanking plate(s), set to Unused for relevant CH.

3.4.8. Supply valve type (Index 71)

Table 3-16. Supply valve type

Sub index	Size [byte]	Access	Default	Content	Description
1	1	R/W	0x01	Supply valve type of CH0	Set the N.O./N.C. of the supply valve type for each CH. 0x00 : N.C. 0x01 : N.O.
...	
16	1	R/W	0x01	Supply valve type of CH15	

Note

- The setting must match the supply valve type fitted in vacuum manifold.
- Diagnostic information will be issued when a supply valve type mismatch is detected. Refer to [Section 3.4.16](#) and [Section 7](#).

3.4.9. Energy saving function (Index 72)

Table 3-17. Energy saving function

Sub index	Size [byte]	Access	Default	Content	Description
1	1	R/W	0x01	Enable/Disable energy saving function of CH0	Set Enable/Disable energy saving function for each CH. Refer to Section 5 . 0x00 : Disable 0x01 : Enable
...	
16	1	R/W	0x01	Enable/Disable energy saving function of CH15	

3.4.10. Pressure range (Index 73)

Table 3-18. Pressure range

Sub index	Size [byte]	Access	Default	Content	Description
1	1	R/W	0x01	Rated pressure range of pressure sensor of CH0	Set rated pressure range of pressure sensor to be used in each CH. 0x00 : -100...200 kPa 0x01 : -100...100 kPa
...	
16	1	R/W	0x01	Rated pressure range of pressure sensor of CH15	

Note

- The setting must match the rated pressure range of sensor fitted in vacuum manifold.

3.4.11. Valve protection count (Index 74)

Table 3-19. Valve protection count

Sub index	Size [byte]	Access	Default (dec)	Content	Description
1	1	R/W	0x0A (10)	Number of settings for valve protection of CH0	Set Enable/Disable valve protection function and its number of times for each CH. The valve protection functions are described below. During operation of energy saving function, if the switching of vacuum generate/stop has reached set number of times, stop subsequent energy saving function and diagnostic information is issued.
...	
16	1	R/W	0x0A (10)	Number of settings for valve protection of CH15	If the value is set to 0, valve protection function is invalid and energy saving function continues to operate. Settable range : 0...100

Note

- For diagnostic information, refer to [Section 3.4.15](#) and [Section 7](#).
- The energy saving function is stopped when the protection count number is exceeded. It can be restarted by either of the following methods :
 - Restarting the SI Unit
 - Turning power supply for output OFF/ON
 - Using the Valve protection release command ([Section 3.4.20](#)).

3.4.12. Current pressure (Index 85)

Table 3-20. Current pressure

Sub index	Size [byte]	Access	Default	Content	Description
1	2	R	0x0000	Current pressure value of CH0	Read current pressure value for each CH. The specification of the value is the same as for PressureValueMonitoring of input process data. Refer to Section 4.1.1 .
...	
16	2	R	0x0000	Current pressure value of CH15	

3.4.13. Valve short circuit status (Index 86)

Table 3-21. Valve short circuit status

Sub index	Size [byte]	Access	Default	Content	Description
1	1	R	0x00	Valve short circuit status of CH0	Read valve short circuit status for each CH. 0x00 : No short circuit 0x01 : Short circuit detected
...	
16	1	R	0x00	Valve short circuit status of CH15	

3.4.14. Pressure sensor failure/disconnection status (Index 87)

Table 3-22. Pressure sensor failure/disconnection status

Sub index	Size [byte]	Access	Default	Content	Description
1	1	R	0x00	Pressure sensor failure/disconnection status of CH0	Read pressure sensor failure/disconnection status for each CH. 0x00 : No failure/disconnection 0x01 : Failure/Disconnection detected Fixed at 0x00 for CHs whose Pressure sensor parameter is set to Unused.
...	
16	1	R	0x00	Pressure sensor failure/disconnection status of CH15	

3.4.15. Valve protection status (Index 88)

Table 3-23. Valve protection status

Sub index	Size [byte]	Access	Default	Content	Description
1	1	R	0x00	Valve protection status of CH0	Read valve protection function status of each CH. 0x00 : No valve protection operation 0x01 : Valve protection operating Fixed at 0x00 for CHs whose parameter setting apply following conditions : - Pressure sensor use parameter is set to Unused - Energy saving function parameter is set to Disable
...	
16	1	R	0x00	Valve protection status of CH15	

3.4.16. Supply valve type status (Index 89)

Table 3-24. Supply valve type status

Sub index	Size [byte]	Access	Default	Content	Description
1	1	R	0x00	Supply valve type mismatch status of CH0	Read supply valve type mismatch status for each CH. 0x00 : No mismatch 0x01 : Mismatch detected Fixed at 0x00 for CHs whose Pressure sensor parameter is set to Unused.
...	
16	1	R	0x00	Supply valve type mismatch status of CH15	

3.4.17. Pressure/Hysteresis parameter failure status (Index 90)

Table 3-25. Pressure/Hysteresis parameter failure status

Sub index	Size [byte]	Access	Default	Content	Description
1	1	R	0x00	Pressure/Hysteresis parameter failure status of CH0	Read Pressure/Hysteresis parameter setting failure status for each CH. 0x00 : No setting failure 0x01 : Setting failure detected Fixed at 0x00 for CHs whose Pressure sensor parameter is set to Unused.
...	
16	1	R	0x00	Pressure/Hysteresis parameter failure status of CH15	

3.4.18. Receive error count (Index 91)

Table 3-26. Receive error count

Subindex	Size[byte]	Access	Default	Content	Description
0	4	R	0x00000000	Error count value of IO-Link received data	Counts parity errors and checksum errors in IO-Link communications. The count is reset to 0 when the power supply for logic/input switched OFF.

3.4.19. Zero clear (Index 145)

Table 3-27. Zero clear

Subindex	Size[byte]	Access	Default	Content	Description
0	1	W	0x00	Zero clear command	Adjust pressure value to 0 kPa at atmospheric pressure. 0x00 : No zero clear request 0x01 : Zero clear request 0x02 : Zero clear correction value reset request

Note

- Zero clear and zero clear correction value reset are carried out in batches for all CHs.
- Zero clear request and zero clear reset request are only processed when the write value changes from 0x00 to 0x01 or 0x00 to 0x02. For this reason, write 0x00 once for the second and subsequent request.

3.4.20. Valve protection release (Index 146)

Table 3-28. Valve protection release

Subindex	Size[byte]	Access	Default	Content	Description
0	1	W	0x00	Valve protection release command	Release of valve protection function and resume energy saving function. Refer to Section 3.4.11 . 0x00 : No valve protection release request 0x01 : Valve protection release request

Note

- Valve protection release is carried out in batches for all CHs.
- Valve protection release request is only processed when the write value changes from 0x00 to 0x01. For this reason, write 0x00 once for the second and subsequent request.

4. Process Data

The process data size occupied by the SI Unit depends on the number of vacuum manifold stations. The process data size occupied is as follows.

Table 4-1. Process data size

Vacuum manifold stations	Input process data	Output process data
4	4 byte	2 byte
8	5 byte	3 byte
12	6 byte	4 byte
16	7 byte	5 byte

4.1. Input process data

Table 4-2. Overview of input process data

byte	Content	Description
0,1	PressureValueMonitoring	Refer to Section 4.1.1.
2	UnitStatus	Refer to Section 4.1.2.
3	Vacuum/ReleaseStatusCH0...3	Refer to Section 4.1.3.
4	Vacuum/ReleaseStatusCH4...7	Refer to Section 4.1.3. Occupy when vacuum manifold consists of 8/12/16 stations.
5	Vacuum/ReleaseStatusCH8...11	Refer to Section 4.1.3. Occupy when vacuum manifold consists of 12/16 stations.
6	Vacuum/ReleaseStatusCH12...15	Refer to Section 4.1.3. Occupy when vacuum manifold consists of 16 stations.

4.1.1. PressureValueMonitoring

The CH to be monitored is selected by the value contained in PressureValueMonitoringChannelSelection ([Section 4.2.1](#)). The CH monitor value is the output process data.

Table 4-3. PressureValueMonitoring

byte	1								0							
bit	15	14	13	12	11	10	9	8	7	6	5	4	3	2	1	0
	Sign								Pressure value							

Table 4-4. Pressure value (Pressure range parameter : -100...100 kPa)

bit 15...0	Pressure value[kPa]
0x0000	0.0
0x0001	0.1
...	...
0x03E7	99.9
0x03E8	100.0 or more
...	Unused
0x8000	Abnormal
...	Unused
0xFC18	-100.0 or less
0xFC19	-99.9
...	...
0xFFFFE	-0.2
0xFFFFF	-0.1

Note

- The table on the left shows an example when Pressure range parameter ([Section 3.4.10](#)) is set to -100...100 kPa for the selected CH.
- The value is fixed at 0x8000 if selected CH does not exist, if Pressure sensor use parameter ([Section 3.4.7](#)) for selected CH set to Unused, if pressure sensor has a short circuit, or if pressure sensor of selected CH has a failure/disconnection.
- 0x03E9...0x7FFF and 0x8001...0xFC17 are unused.

Table 4-5. Pressure value (Pressure range parameter : -100...200 kPa)

bit 15...0	Pressure value[kPa]
0x0000	0.0
0x0001	0.1
...	...
0x07CF	199.9
0x07D0	200.0 or more
...	Unused
0x8000	Abnormal
...	Unused
0xFC18	-100.0 or less
0xFC19	-99.9
...	...
0xFFFFE	-0.2
0xFFFFF	-0.1

Note

- The table on the left shows an example when Pressure range parameter ([Section 3.4.10](#)) is set to -100...200 kPa for the selected CH.
- The value is fixed at 0x8000 if selected CH does not exist, if Pressure sensor use parameter ([Section 3.4.7](#)) for selected CH set to Unused, if pressure sensor has a short circuit, or if pressure sensor of selected CH has a failure/disconnection.
- 0x07D1...0x7FFF and 0x8001...0xFC17 are unused.

Note

- The switching timing of the PressureValueMonitoring CH may differ between the process data of the IO-Link and the process data of the upper communication.

4.1.2. UnitStatus

Table 4-6.UnitStatus

byte	bit	Content	Description
2	0	Valve short circuit	0 : No valves have a short circuit. 1 : At least one valve has a short circuit.
	1	Pressure sensor short circuit	0 : No pressure sensors have a short circuit. 1 : At least one pressure sensor has a short circuit.
	2	Pressure sensor failure/disconnection	0 : No pressure sensors have a failure/disconnection. 1 : At least one pressure sensor has a failure/disconnection.
	3	Manifold connection error	0 : Normal connection to vacuum manifold. 1 : Disconnection between vacuum manifold and the SI Unit.
	4	Power supply diagnostics for logic/input	0 : Power supply for logic/input is present. 1 : Power supply for logic/input is low. (< approx. 16.8 VDC)
	5	Supply valve type setting mismatch	0 : Supply valve type parameter setting is normal. 1 : The setting of Supply valve type parameter has a mismatch on at least one CH.
	6	Pressure/Hysteresis parameter setting failure	0 : Pressure/Hysteresis parameter setting is normal. 1 : The setting of Pressure/Hysteresis parameter has a failure on at least one CH.
	7	Valve protection	0 : Valve protection function is not operating 1 : Valve protection function is operating on at least one CH.

4.1.3. Vacuum/ReleaseStatus

Table 4-7. Vacuum/ReleaseStatus

byte	bit	Content	Description	Remark
3	0	Vacuum confirmation of CH0 ejector	0 : No vacuum adsorption or vacuum release 1 : During vacuum adsorption or vacuum release	
	1	Release confirmation of CH0 ejector		
	2	Vacuum confirmation of CH1 ejector		
	3	Release confirmation of CH1 ejector		
	4	Vacuum confirmation of CH2 ejector		
	5	Release confirmation of CH2 ejector		
	6	Vacuum confirmation of CH3 ejector		
	7	Release confirmation of CH3 ejector		
4	0	Vacuum confirmation of CH4 ejector	0 : No vacuum adsorption or vacuum release 1 : During vacuum adsorption or vacuum release	Occupy when vacuum manifold consists of 8/12/16 stations.
	1	Release confirmation of CH4 ejector		
	2	Vacuum confirmation of CH5 ejector		
	3	Release confirmation of CH5 ejector		
	4	Vacuum confirmation of CH6 ejector		
	5	Release confirmation of CH6 ejector		
	6	Vacuum confirmation of CH7 ejector		
	7	Release confirmation of CH7 ejector		
5	0	Vacuum confirmation of CH8 ejector	0 : No vacuum adsorption or vacuum release 1 : During vacuum adsorption or vacuum release	Occupy when vacuum manifold consists of 12/16 stations.
	1	Release confirmation of CH8 ejector		
	2	Vacuum confirmation of CH9 ejector		
	3	Release confirmation of CH9 ejector		
	4	Vacuum confirmation of CH10 ejector		
	5	Release confirmation of CH10 ejector		
	6	Vacuum confirmation of CH11 ejector		
	7	Release confirmation of CH11 ejector		
6	0	Vacuum confirmation of CH12 ejector	0 : No vacuum adsorption or vacuum release 1 : During vacuum adsorption or vacuum release	Occupy when vacuum manifold consists of 16 stations.
	1	Release confirmation of CH12 ejector		
	2	Vacuum confirmation of CH13 ejector		
	3	Release confirmation of CH13 ejector		
	4	Vacuum confirmation of CH14 ejector		
	5	Release confirmation of CH14 ejector		
	6	Vacuum confirmation of CH15 ejector		
	7	Release confirmation of CH15 ejector		

4.2. Output process data

Table 4-8. Overview of output process data

byte	Content	Description
0	PressureValueMonitoringChannelSelection	Refer to Section 4.2.1.
1	Vacuum/ReleaseInstructionCH0...3	Refer to Section 4.2.2.
2	Vacuum/ReleaseInstructionCH4...7	Refer to Section 4.2.2. Occupy in case of vacuum manifold 8/12/16 stations.
3	Vacuum/ReleaseInstructionCH8...11	Refer to Section 4.2.2. Occupy in case of vacuum manifold 12/16 stations.
4	Vacuum/ReleaseInstructionCH12...15	Refer to Section 4.2.2. Occupy in case of vacuum manifold 16 stations.

4.2.1. PressureValueMonitoringChannelSelection

Select the CH to be referenced in the input process data PressureValueMonitoring ([Section 4.1.1](#)).

Table 4-9. PressureValueMonitoringChannelSelection

byte	bit								Content
	7	6	5	4	3	2	1	0	
0	0	0	0	0	0	0	0	0	Select CH0 for PressureValueMonitoring
	0	0	0	0	0	0	0	1	Select CH1 for PressureValueMonitoring
	0	0	0	0	0	0	1	0	Select CH2 for PressureValueMonitoring
	0	0	0	0	0	0	1	1	Select CH3 for PressureValueMonitoring
	0	0	0	0	0	1	0	0	Select CH4 for PressureValueMonitoring
	0	0	0	0	0	1	0	1	Select CH5 for PressureValueMonitoring
	0	0	0	0	0	1	1	0	Select CH6 for PressureValueMonitoring
	0	0	0	0	0	1	1	1	Select CH7 for PressureValueMonitoring
	0	0	0	0	1	0	0	0	Select CH8 for PressureValueMonitoring
	0	0	0	0	1	0	0	1	Select CH9 for PressureValueMonitoring
	0	0	0	0	1	0	1	0	Select CH10 for PressureValueMonitoring
	0	0	0	0	1	0	1	1	Select CH11 for PressureValueMonitoring
	0	0	0	0	1	1	0	0	Select CH12 for PressureValueMonitoring
	0	0	0	0	1	1	0	1	Select CH13 for PressureValueMonitoring
	0	0	0	0	1	1	1	0	Select CH14 for PressureValueMonitoring
0	0	0	0	1	1	1	1	Select CH15 for PressureValueMonitoring	

4.2.2. Vacuum/ReleaseInstruction

Table 4-10. Vacuum/ReleaseInstruction

byte	bit	Content	Description	Remark
3	0	Vacuum instruction of CH0 ejector	Supply valve type : N.O. 0 : Vacuum instruction ON or release instruction OFF	
	1	Release instruction of CH0 ejector	1 : Vacuum instruction OFF or release instruction ON	
	2	Vacuum instruction of CH1 ejector	Supply valve type : N.C. 0 : Vacuum instruction OFF or release instruction OFF	
	3	Release instruction of CH1 ejector		
	4	Vacuum instruction of CH2 ejector	Supply valve type : N.O. 0 : Vacuum instruction ON or release instruction OFF 1 : Vacuum instruction OFF or release instruction ON	
	5	Release instruction of CH2 ejector		
	6	Vacuum instruction of CH3 ejector		
	7	Release instruction of CH3 ejector		
4	0	Vacuum instruction of CH4 ejector	Supply valve type : N.C. 0 : Vacuum instruction OFF or release instruction OFF 1 : Vacuum instruction ON or release instruction ON	Occupy when vacuum manifold consists of 8/12/16 stations.
	1	Release instruction of CH4 ejector		
	2	Vacuum instruction of CH5 ejector		
	3	Release instruction of CH5 ejector		
	4	Vacuum instruction of CH6 ejector		
	5	Release instruction of CH6 ejector		
	6	Vacuum instruction of CH7 ejector		
	7	Release instruction of CH7 ejector		
5	0	Vacuum instruction of CH8 ejector	Supply valve type : N.O. 0 : Vacuum instruction ON or release instruction OFF 1 : Vacuum instruction OFF or release instruction ON	Occupy when vacuum manifold consists of 12/16 stations.
	1	Release instruction of CH8 ejector		
	2	Vacuum instruction of CH9 ejector		
	3	Release instruction of CH9 ejector		
	4	Vacuum instruction of CH10 ejector		
	5	Release instruction of CH10 ejector		
	6	Vacuum instruction of CH11 ejector		
	7	Release instruction of CH11 ejector		
6	0	Vacuum instruction of CH12 ejector	Supply valve type : N.O. 0 : Vacuum instruction ON or release instruction OFF 1 : Vacuum instruction OFF or release instruction ON	Occupy when vacuum manifold consists of 16 stations.
	1	Release instruction of CH12 ejector		
	2	Vacuum instruction of CH13 ejector		
	3	Release instruction of CH13 ejector		
	4	Vacuum instruction of CH14 ejector		
	5	Release instruction of CH14 ejector		
	6	Vacuum instruction of CH15 ejector		
	7	Release instruction of CH15 ejector		

Note

- "0" indicates that the supply or release valve is energization OFF and "1" indicates that the supply or release valve is energization ON.
- If vacuum instruction and release instruction are turned ON simultaneously on one CH, the vacuum instruction has priority and only the supply valve is opened.

5. Example of energy saving operation of ejector

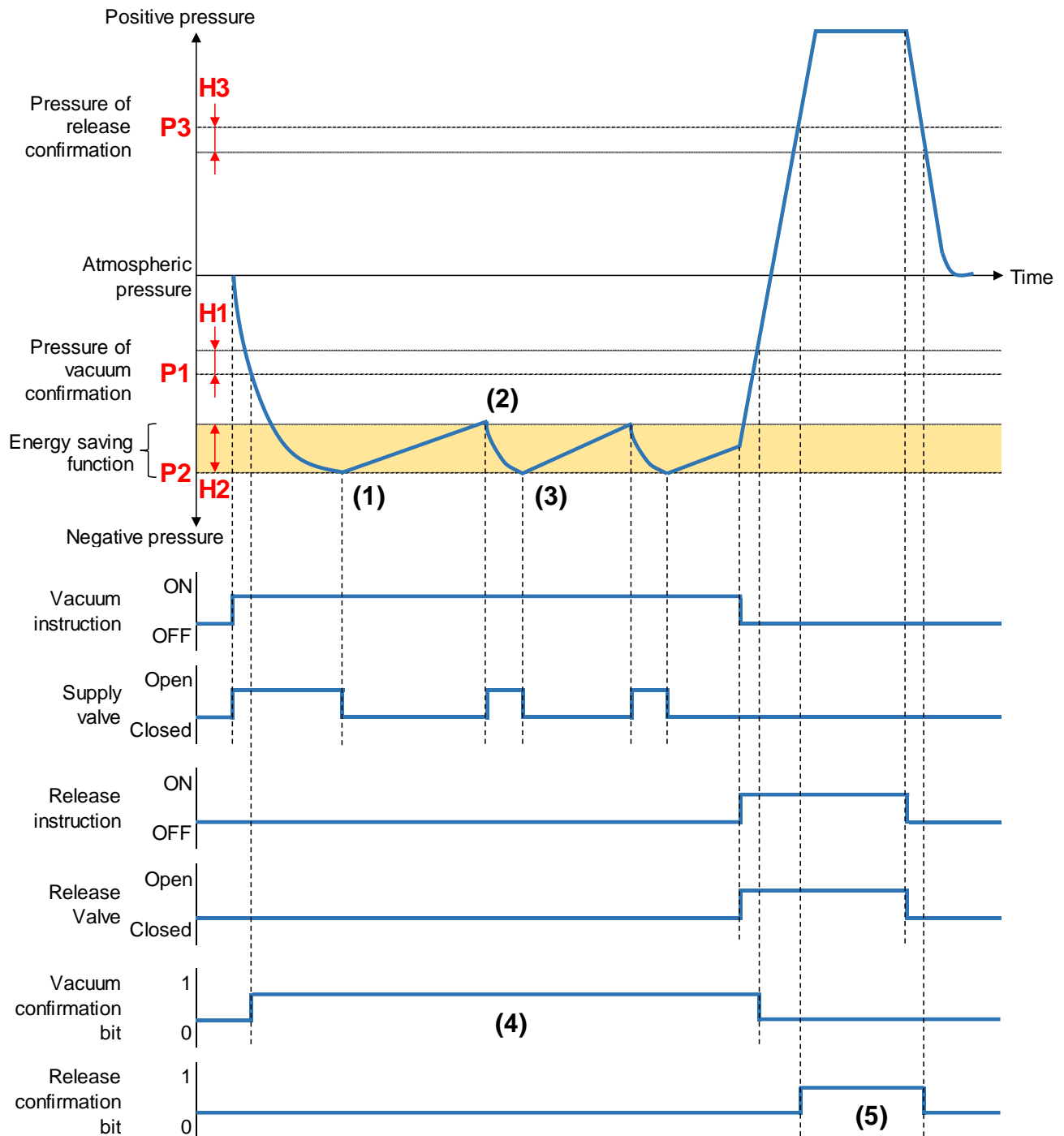
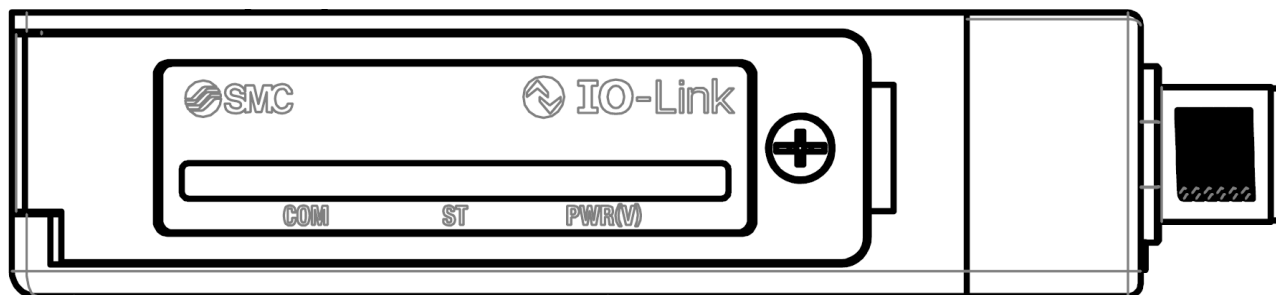

Fig 5-1. Sample of ejector operation

- (1) When the vacuum instruction is ON, the supply valve is automatically closed when the vacuum pressure reaches P2.
- (2) When the vacuum pressure drops by P2-H2, the supply valve is automatically opened again.
- (3) Repeat steps (1) and (2) unless the valve protection function is activated.
- (4) The vacuum confirmation bit is set to 1 until the vacuum pressure reaches P1 and then drops to P1-H1.
- (5) The release confirmation bit is set to 1 until the release pressure reaches P3 and then drops to P3-H3.

6. LED indication



LED	Status	Description
COM	Green flashing (900 ms ON, 100 ms OFF)	Power supply for logic/input is present and IO-Link communication is active.
	Green ON	Power supply for logic/input is present and IO-Link communication is inactive.
	OFF	Power supply for logic/input is low (< approx. 16.8 VDC) or not present.
ST	OFF	Operating normally.
	Red ON	One of the following may have occurred. (DeviceStatus : Failure) <ul style="list-style-type: none"> Valve has a short circuit. Pressure sensor has a short circuit. Pressure sensor has a failure or a disconnection. No connection or a disconnection between the SI Unit and vacuum manifold. There is a firmware error.
	Orange ON	One of the following may have occurred. (DeviceStatus : Maintenance-Required) <ul style="list-style-type: none"> Power supply for logic/input is low. (< approx. 16.8 VDC) The setting of Supply valve type parameter has a mismatch. The setting of Pressure/Hysteresis parameter has a failure. Valve protection function is operating.
	Green flashing (1 Hz)	A firmware update is being performed via IO-Link communications or the firmware update has failed.
PWR(V)	Green ON	Power supply for output is present.
	OFF	Power supply for output is not present.

Fig 6-1. LED indication

7. Event

When an error occurs, an event with the same content as DetailedDeviceStatus ([Section 3.3.3](#)) will occur.

Table 7-1. Event

Content	Status	EventQualifier					Event Code																					
		Value	MODE bit 6-7	TYPE bit 4-5	SOURCE bit 3	INSTANCE bit 0-2																						
Device hardware failure	Occur	0xF4	11b(3)(appears)	11b (3) (Error)	0 (Device)	100b (4) (Application)	0x5000																					
	Release	0xB4	10b(2)(disappears)																									
Non volatile memory failure	Occur	0xF4	11b(3)(appears)				11b (3) (Error)	0 (Device)	100b (4) (Application)	0x5011																		
	Release	0xB4	10b(2)(disappears)																									
Valve short circuit	Occur	0xF4	11b(3)(appears)							11b (3) (Error)	0 (Device)	100b (4) (Application)	0x1800															
	Release	0xB4	10b(2)(disappears)																									
Pressure sensor short circuit	Occur	0xF4	11b(3)(appears)										11b (3) (Error)	0 (Device)	100b (4) (Application)	0x1801												
	Release	0xB4	10b(2)(disappears)																									
Pressure sensor failure/disconnection	Occur	0xF4	11b(3)(appears)													11b (3) (Error)	0 (Device)	100b (4) (Application)	0x1802									
	Release	0xB4	10b(2)(disappears)																									
Vacuum manifold no connection	Occur	0xF4	11b(3)(appears)																11b (3) (Error)	0 (Device)	100b (4) (Application)	0x1803						
	Release	0xB4	10b(2)(disappears)																									
Vacuum manifold disconnection	Occur	0xF4	11b(3)(appears)																			11b (3) (Error)	0 (Device)	100b (4) (Application)	0x1804			
	Release	0xB4	10b(2)(disappears)																									
Firmware error	Occur	0xF4	11b(3)(appears)																						11b (3) (Error)	0 (Device)	100b (4) (Application)	0x1805
	Release	0xB4	10b(2)(disappears)																									
Voltage drop of power supply for logic/input	Occur	0xE4	11b(3)(appears)	10b (2) (Warning)	0 (Device)	100b (4) (Application)																						0x5111
	Release	0xA4	10b(2)(disappears)																									
Supply valve type parameter mismatch	Occur	0xE4	11b(3)(appears)				10b (2) (Warning)	0 (Device)	100b (4) (Application)																			0x1850
	Release	0xA4	10b(2)(disappears)																									
Pressure/Hysteresis parameter setting failure	Occur	0xE4	11b(3)(appears)							10b (2) (Warning)	0 (Device)	100b (4) (Application)																0x1851
	Release	0xA4	10b(2)(disappears)																									
Valve protection	Occur	0xE4	11b(3)(appears)										10b (2) (Warning)	0 (Device)	100b (4) (Application)													0x1852
	Release	0xA4	10b(2)(disappears)																									
DC_UPLOAD_REQ	-	0x54	01b(1)(single shot)													01b (1) (Notification)	0 (Device)	100b (4) (Application)										0xFF91

8. Specification

8.1. Dimensions

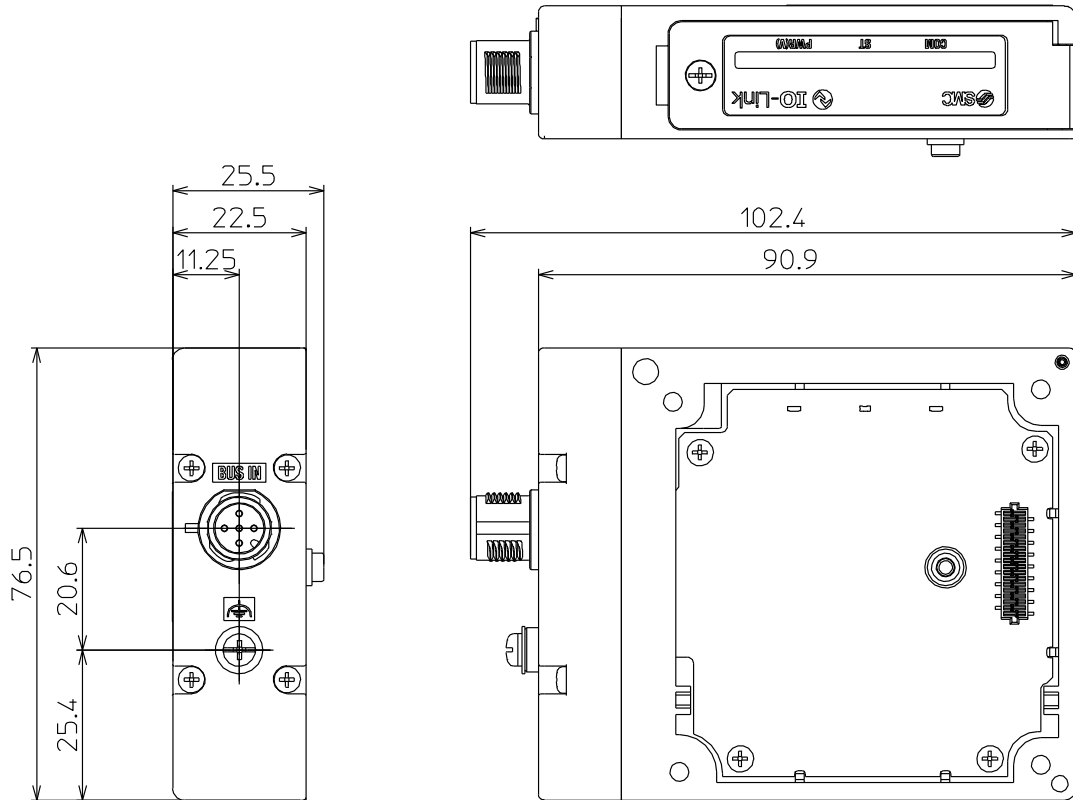

Fig 8-1. Dimensions of the SI Unit

8.2. Specifications

Table 8-1. Specifications

Item	Specification	
General		
Dimensions (W x L x H)mm	25.5 x 102.4 x 76.5	
Weight	150 g	
Housing materials	PBT	
Maximum number of ejectors	16	
Maximum number of sensors	16	
Applicable standard	CE/UKCA Marked, RoHS directive	
Withstand voltage	500 VAC 1 min. (between FE and all accessible terminals)	
Insulation resistance	10 Mohm or more (500 VDC between FE and all accessible terminals)	
Ambient temperature	Operating temperature range : 0...50 °C Storage temperature range : -20...60 °C	
Operating humidity range	35...85 %RH (non-condensing)	
Electrical		
Internal current consumption (L+ power)	100 mA or less	
Protection against polarity reversal	Yes (Power supplies for logic/input and output)	
For logic/input	Operating voltage range	24 VDC +10%/-10%
	Under-voltage detection	approx. 16.8 VDC
For output	Operating voltage range	24 VDC +10%/-5%
Isolation	Yes (Between power supplies for logic/input and output)	
Fieldbus		
Bus protocol	IO-Link	
Version	1.1	
IO-Link type	Device	
IO-Link Port Class	Class B	
Transmission rate	COM2 (38.4 kbps)	
Firmware update function	Yes	
Vendor ID	0x0083 (131)	

9. Accessories

(1) Cable with communication/power connector on both sides (M12 - M12, Straight)

Part number : EX9-AC 005-SSPS

● Cable length (L)

005	500 mm
010	1000 mm
020	2000 mm
030	3000 mm
050	5000 mm
100	10000 mm

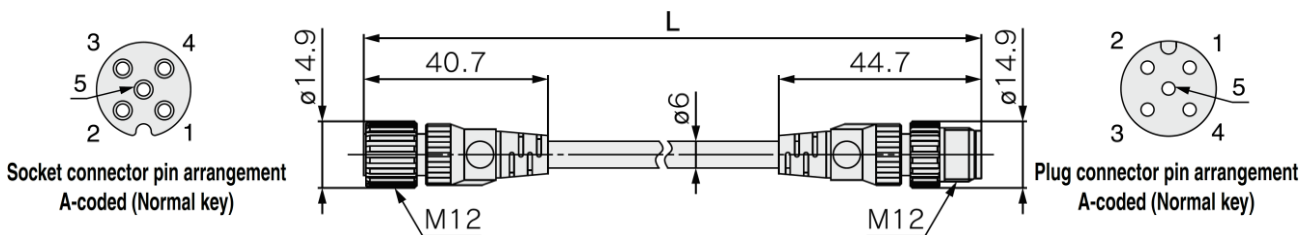

Item	Specification
Connector	M12 Straight <-> M12 Straight
Cable O.D.	φ6 mm
Normal cross section	0.3 mm ² /AWG22
Wire diameter (including insulator)	1.5 mm
Min. bending radius (Fixed)	40 mm

Pin No.	Cable colour : Signal
1	Brown : L+ (+24 V for logic/input)
2	White : P24 (+24 V for output)
3	Blue : L- (0 V for logic/input)
4	Black : C/Q (IO-Link communication data)
5	Grey : N24 (0 V for output)

Fig 9-1. EX9-AC***-SSPS

(2) Cable with communication/power connector on both sides (M12 – M12, Angle)

Part number : EX9-AC 005-SAPA

• Cable length (L)

005	500 mm
010	1000 mm
020	2000 mm
030	3000 mm
050	5000 mm
100	10000 mm

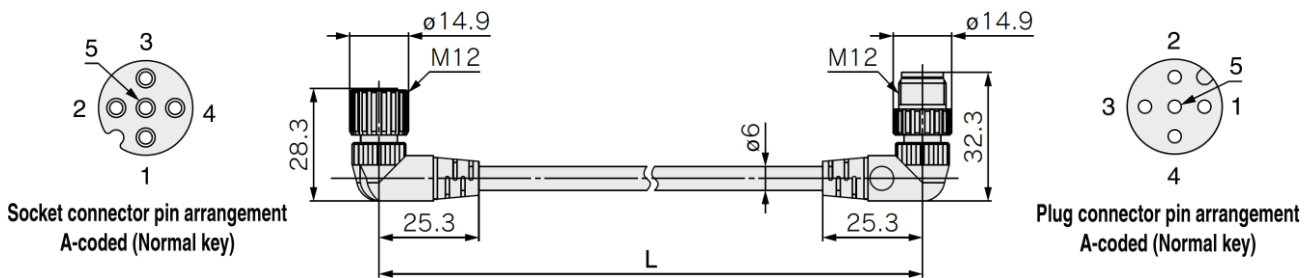

Item	Specification
Connector	M12 Straight <-> M12 Straight
Cable O.D.	φ6 mm
Normal cross section	0.3 mm ² /AWG22
Wire diameter (including insulator)	1.5 mm
Min. bending radius (Fixed)	40 mm

Pin No.	Cable colour : Signal
1	Brown : L+ (+24 V for logic/input)
2	White : P24 (+24 V for output)
3	Blue : L- (0 V for logic/input)
4	Black : C/Q (IO-Link communication data)
5	Grey : N24 (0 V for output)

Fig 9-2. EX9-AC***-SAPA

(3)Y branch connector

Part number : EX9-ACY02-S

This connector is used to supply power for output by branching the communication/power cable in cases where IO-Link Port Class A IO-Link master is used.

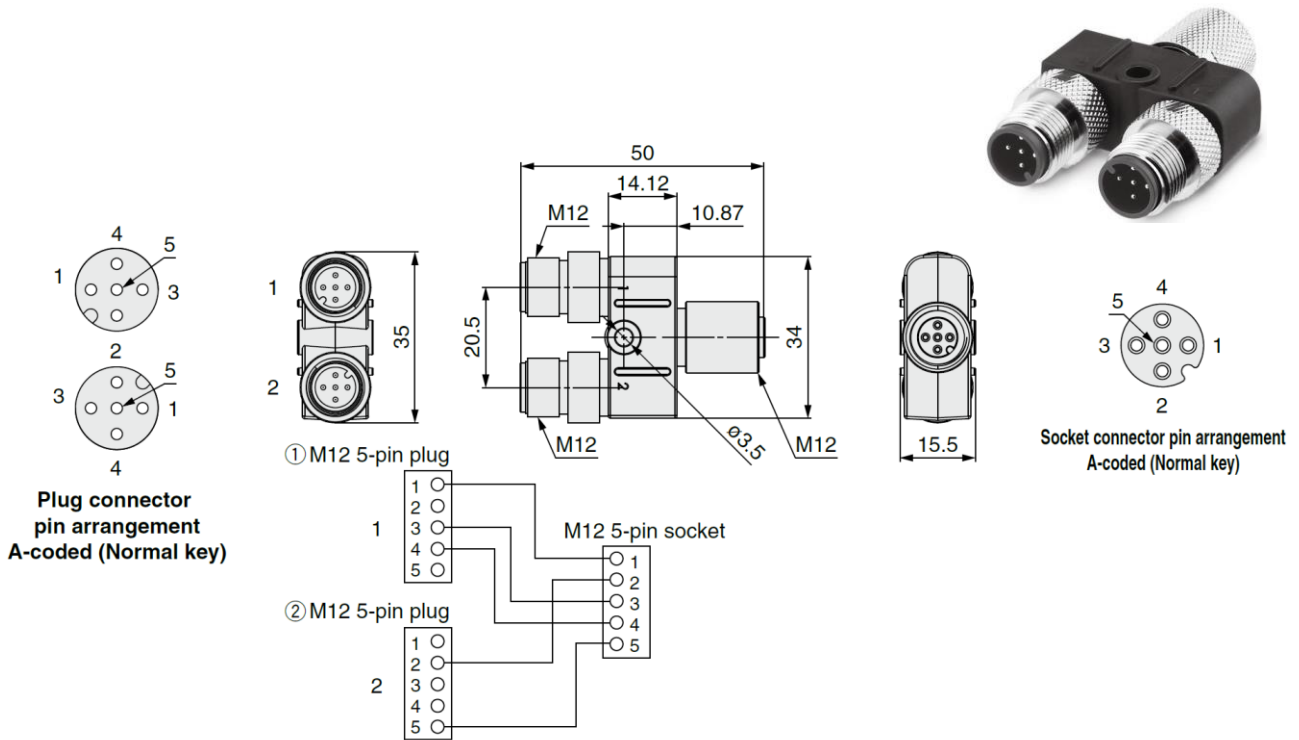

Power cable side pin arrangement for output when using Y branch connector

Pin No.	Designation	Content
1	-	Unused
2	P24	+24 V for output
3	-	Unused
4	-	Unused
5	N24	0 V for output

Fig 9-3. EX9-ACY02-S

(4) Cable with communication/power connector on one side

Part number : EX500-AP010-S

Connector specification

S	Straight
A	Angle

Cable length (L)

1	1000 mm
5	5000 mm

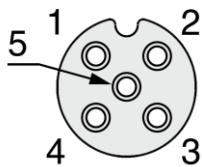

**Socket connector
pin arrangement
A-coded (Normal key)**

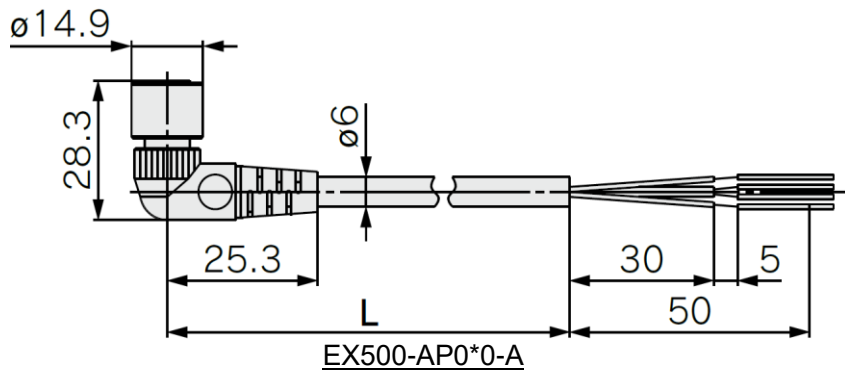
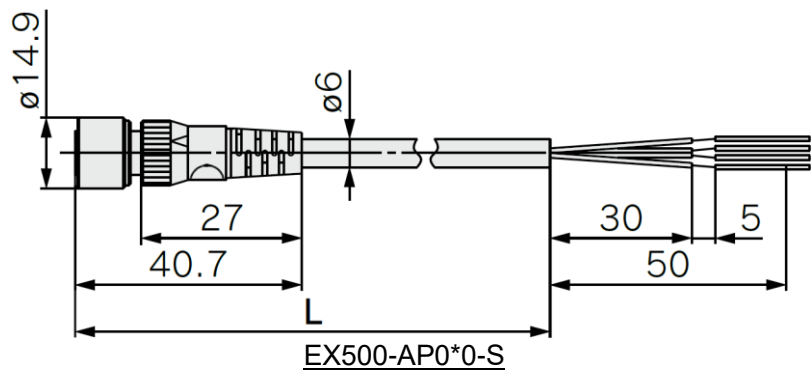

Item	Specification
Cable O.D.	$\phi 6$ mm
Nominal cross section	0.3 mm ² /AWG22
Wire diameter (Including insulator)	1.5 mm
Min. bending radius (Fixed)	40 mm

Pin No.	Cable colour : Signal
1	Brown : L+ (+24 V for logic/input)
2	White : P24 (+24 V for output)
3	Blue : L- (0 V for logic/input)
4	Black : C/Q (IO-Link communication data)
5	Grey : N24 (0 V for output)

Fig 9-4. EX500-AP0*0-*

(5) Cable with communication/power connector on one side (SPEEDCON)

Part number : PCA-140180 4

● Cable length (L)

4	1500 mm
5	3000 mm
6	5000 mm

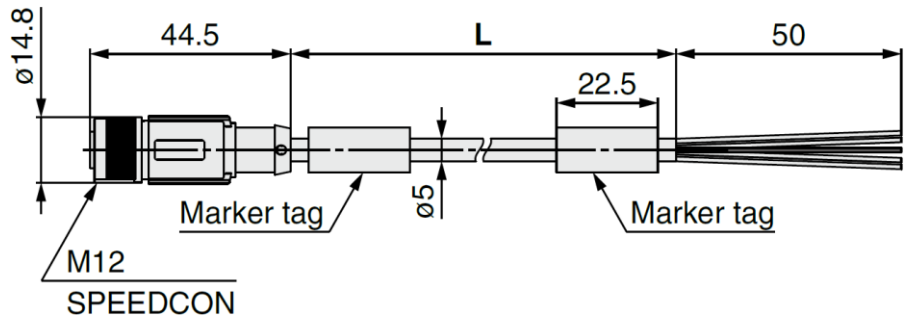
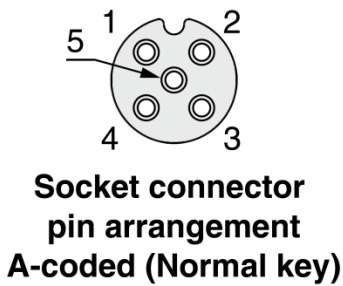

Item	Specification
Connector	M12 Straight (SPEEDCON)
Cable O.D.	$\phi 5$ mm
Nominal cross section	0.34 mm ² /AWG22
Wire diameter (Including insulator)	1.27 mm
Min. bending radius (Fixed)	21.7 mm

Pin No.	Cable colour : Signal
1	Brown : L+ (+24 V for logic/input)
2	White : P24 (+24 V for output)
3	Blue : L- (0 V for logic/input)
4	Black : C/Q (IO-Link communication data)
5	Green/Yellow : N24 (0 V for output)

Fig 9-5. PCA-140180*

10. Troubleshooting

The following shows the troubleshooting related the SI Unit.

Table 10-1. Troubleshooting related COM LED indication

No.	Content	Probable causes	Checking methods and measures
1	COM LED is OFF.	Power supply for logic/input is low (< approx. 16.8 VDC) or not present.	Check the power supply voltage for logic/input being supplied to the SI Unit. Supply the voltage considering the voltage drop on the wiring.
		The communication/power cable is broken.	Check the connection of the communication/power cable.
2	COM LED is green ON. The port LED of the IO-Link master is green flashing *.	The communication/power cable is broken.	Check the connection of the communication/power cable.
3	COM LED is green ON. The port LED of the IO-Link master is green ON *.	The IO-Link master port is not in IO-Link mode.	Set the IO-Link master port to IO-Link mode.
		Process data size of the IO-Link master is smaller than the process data size of the SI Unit.	Set the process data size of the IO-Link master to be larger than the process data size occupied by the SI Unit.
4	COM LED is green ON. The port LED of the IO-Link master is green blinking fast *.	The IO-Link master has detected a device matching error.	Disable the device matching function on the IO-Link master or connect an SI Unit that matches the DeviceID or SerialNumber registered in the IO-Link master.

Note

- LED indicator status may vary depending upon the IO-Link master in use. Check the specification of the IO-Link master for details.

Table 10-2. Troubleshooting related ST LED indication

No.	Content	Probable causes	Checking methods and measures
1	ST LED is red ON.	Valve has a short circuit.	Check Valve short circuit status (Section 3.4.13) to identify which CH(s) have a short circuit. Refer to the manual for the vacuum manifold to check the relevant ejector(s) connections and replace the ejector(s) if necessary.
		Pressure sensor has a short circuit.	Refer to the manual for the vacuum manifold to check all ejectors connections and replace the ejector(s) if necessary.
		Pressure sensor has a failure or a disconnection.	Check Pressure sensor failure/disconnection status (Section 3.4.14) to identify which CH(s) have a failure/disconnection. Refer to the manual for the vacuum manifold to check the relevant ejector(s) connections and replace the ejector(s) if necessary. If the vacuum manifold includes a blanking plate, check Pressure sensor use parameter (Section 3.4.7) settings.
		No connection or a disconnection has occurred between the SI Unit and vacuum manifold.	Check the connection between the SI Unit and vacuum manifold. Restart the SI Unit and vacuum manifold.
		There is a firmware error.	Download the latest firmware and update the firmware.
2	ST LED is orange ON.	Power supply for logic/input is low. (< approx. 16.8 VDC)	Check the power supply voltage for logic/input being supplied to the SI Unit. Supply the voltage considering the voltage drop on the wiring.
		The setting of Supply valve type parameter has a mismatch.	Check Supply valve type status (Section 3.4.16) to identify which CH(s) have a mismatch. Check and modify Supply valve type parameter (Section 3.4.8) setting of the relevant CH(s), then carry out a vacuum instruction (Section 4.2.2).
		The setting of Pressure/Hysteresis parameter has a failure.	Check Pressure/Hysteresis parameter failure status (Section 3.4.17) to identify which CH(s) have a failure. Check and modify Pressure/Hysteresis parameter setting of the relevant CH(s).
		Valve protection function is operating.	Check Valve protection status (Section 3.4.15) to identify which CH(s) the function is operating on. Check and if necessary replace the vacuum pad or air tubing etc. on the relevant CH(s). For details on the valve protection function, refer to Section 3.4.11 .
3	ST LED is green flashing.	During firmware update via IO-Link or firmware update failed.	If the firmware update fails, update the firmware again.

Table 10-3. Troubleshooting related PWR(V) LED indication

No.	Content	Probable causes	Checking methods and measures
1	PWR(V) LED is OFF.	Power supply for output not present.	Check the power supply voltage for output being supplied to the SI Unit. Supply the voltage considering the voltage drop on the wiring.
		The communication/power cable is broken.	Check the connection of the communication/power cable.

Revision history

SMC Corporation

4-14-1, Sotokanda, Chiyoda-ku, Tokyo 101-0021 JAPAN

Tel: + 81 3 5207 8249 Fax: +81 3 5298 5362

URL <http://www.smcworld.com>

Note: Specifications are subject to change without prior notice and any obligation on the part of the manufacturer.
© 2022 SMC Corporation All Rights Reserved.

