



# Operation Manual

## PRODUCT NAME

*Micro Mist Separator*

## MODEL / Series / Product Number

AMD50-(F,N)06 ~ (F,N)10(B,C,D)(-J,L,R,W,Z)-D  
AMD60-(F,N)10(B,C,D)(-J,L,R,W,Z)-D

**SMC Corporation**

# Contents

	Page
1. Safety Instructions	2 to 6
2. Application	7
3. Standard specifications	7
4. How to Order	8
5. Construction / Options / Replacement parts	9
6. Bowl assembly specifications	10 to 11
6-1. Bowl assembly for AMD50	10
6-2. Bowl assembly for AMD60	11
7. Assembly of Optional parts	12
8. Operation and Adjustment	13 to 14
8-1. Discharge from the product with drain cock	13
8-2. Manual drain discharge from the auto drain	14
9. Troubleshooting	15
10. How to Replace the Components	16 to 17
10-1. Bowl assembly Replacement	16
10-2. Element Replacement	17
11. Disassembly Drawing	18
12. Dimensions	19



# Micro Mist Separator Safety Instructions

These safety instructions are intended to prevent hazardous situations and/or equipment damage. These instructions indicate the level of potential hazard with the labels of "Caution," "Warning" or "Danger." They are all important notes for safety and must be followed in addition to International Standards (ISO/IEC)\*1), and other safety regulations.

\*1) ISO 4414: Pneumatic fluid power -- General rules relating to systems.

ISO 4413: Hydraulic fluid power -- General rules relating to systems.

IEC 60204-1: Safety of machinery -- Electrical equipment of machines .(Part 1: General requirements)

ISO 10218: Manipulating industrial robots -Safety.

etc.



## Caution

**Caution** indicates a hazard with a low level of risk which, if not avoided, could result in minor or moderate injury.



## Warning

**Warning** indicates a hazard with a medium level of risk which, if not avoided, could result in death or serious injury.



## Danger

**Danger** indicates a hazard with a high level of risk which, if not avoided, will result in death or serious injury.

## Warning

### **1. The compatibility of the product is the responsibility of the person who designs the equipment or decides its specifications.**

Since the product specified here is used under various operating conditions, its compatibility with specific equipment must be decided by the person who designs the equipment or decides its specifications based on necessary analysis and test results.

The expected performance and safety assurance of the equipment will be the responsibility of the person who has determined its compatibility with the product.

This person should also continuously review all specifications of the product referring to its latest catalog information, with a view to giving due consideration to any possibility of equipment failure when configuring the equipment.

### **2. Only personnel with appropriate training should operate machinery and equipment.**

The product specified here may become unsafe if handled incorrectly.

The assembly, operation and maintenance of machines or equipment including our products must be performed by an operator who is appropriately trained and experienced.

### **3. Do not service or attempt to remove product and machinery/equipment until safety is confirmed.**

1. The inspection and maintenance of machinery/equipment should only be performed after measures to prevent falling or runaway of the driven objects have been confirmed.

2. When the product is to be removed, confirm that the safety measures as mentioned above are implemented and the power from any appropriate source is cut, and read and understand the specific product precautions of all relevant products carefully.

3. Before machinery/equipment is restarted, take measures to prevent unexpected operation and malfunction.

### **4. Contact SMC beforehand and take special consideration of safety measures if the product is to be used in any of the following conditions.**

1. Conditions and environments outside of the given specifications, or use outdoors or in a place exposed to direct sunlight.

2. Installation on equipment in conjunction with atomic energy, railways, air navigation, space, shipping, vehicles, military, medical treatment, combustion and recreation, or equipment in contact with food and beverages, emergency stop circuits, clutch and brake circuits in press applications, safety equipment or other applications unsuitable for the standard specifications described in the product catalog.

3. An application which could have negative effects on people, property, or animals requiring special safety analysis.

4. Use in an interlock circuit, which requires the provision of double interlock for possible failure by using a mechanical protective function, and periodical checks to confirm proper operation.



# Micro Mist Separator Safety Instructions

## **Caution**

**The product is provided for use in manufacturing industries.**

The product herein described is basically provided for peaceful use in manufacturing industries.

If considering using the product in other industries, consult SMC beforehand and exchange specifications or a contract if necessary.

If anything is unclear, contact your nearest sales branch.

## **Limited warranty and Disclaimer/Compliance Requirements**

The product used is subject to the following “Limited warranty and Disclaimer” and “Compliance Requirements”.

Read and accept them before using the product.

### **Limited warranty and Disclaimer**

**1. The warranty period of the product is 1 year in service or 1.5 years after the product is delivered, whichever is first.\*2)**

**Also, the product may have specified durability, running distance or replacement parts. Please consult your nearest sales branch.**

**2. For any failure or damage reported within the warranty period which is clearly our responsibility, a replacement product or necessary parts will be provided.**

**This limited warranty applies only to our product independently, and not to any other damage incurred due to the failure of the product.**

**3. Prior to using SMC products, please read and understand the warranty terms and disclaimers noted in the specified catalog for the particular products.**

**\*2) Vacuum pads are excluded from this 1 year warranty.**

**A vacuum pad is a consumable part, so it is warranted for a year after it is delivered.**

**Also, even within the warranty period, the wear of a product due to the use of the vacuum pad or failure due to the deterioration of rubber material are not covered by the limited warranty.**

### **Compliance Requirements**

**1. The use of SMC products with production equipment for the manufacture of weapons of mass destruction(WMD) or any other weapon is strictly prohibited.**

**2. The exports of SMC products or technology from one country to another are governed by the relevant security laws and regulation of the countries involved in the transaction. Prior to the shipment of a SMC product to another country, assure that all local rules governing that export are known and followed.**

## **Caution**

**SMC products are not intended for use as instruments for legal metrology.**

Measurement instruments that SMC manufactures or sells have not been qualified by type approval tests relevant to the metrology (measurement) laws of each country.

Therefore, SMC products cannot be used for business or certification ordained by the metrology (measurement) laws of each country.

## Precautions for Design

### Warning

- 1) Carefully consider the application, required specifications, and operating conditions (pressure, flow rate, temperature, environment and power supply) in accordance with the latest catalog (SMC website), making sure not to exceed the specification range.
- 2) Consult SMC if no leakage is allowed due to the environment, or if the operating fluid is not air.
- 3) This product cannot be used in the following environments.
  - Atmosphere containing corrosive gas, organic solvent, or chemical agent solution is, or a location where any of these substances is attached.
  - Atmosphere containing with sea water or water or containing steam, or a location where any of these substances is attached.
  - Locations subject to direct sunlight (Block direct sunlight to the product to prevent deterioration due to ultraviolet rays or temperature rise).
  - Where the product is exposed to heat sources or in areas that the product is exposed to radiant heat.
  - Where impact or vibration is present.
  - In a location with high humidity and a large quantity of dust.
  - Outdoor.
  - Mounting on vehicle or vessel (The product may be damaged due to excessive vibration).Note) The display window of the element service indicator of semi standard products is made of nylon.
- 4) For air blow applications, prevent airborne particles from the operating environment entering into the compressed air stream, or foreign matter may adhere to the workpiece during the air blow.
- 5) If the air equipment is mounted on the outlet of the product, particles will be generated from the equipment and required cleanliness may not be obtained. Instead, install the air equipment at the inlet.

### Caution

- 1) Applications in which the difference between the inlet and outlet pressure exceeds 0.1MPa must be avoided. Or the element is broken.

## Selection

### Warning

- 1) Grease is used on the internal sliding parts and seals. The grease may flow to the outlet side. If this is not acceptable, please consult SMC.
- 2) Select the model so that the maximum discharge value (instantaneous) of the flow rate will not exceed the rated air capacity. If the flowrate exceeds the maximum air flow capacity, it may cause spillage of drainage and oil to the outlet side, and damage equipment downstream.
- 3) N.O. type auto drain should be operated under the following conditions to avoid operating failure. Operating compressor: 0.75kW or more. Discharged flow rate: 100L/min (ANR) or more. When using 2 or more auto drains, multiply the value above by the number of auto drains to find the capacity of the compressors you will need. For example, when using 2 auto drains, 1.5kW (200L/min (ANR)) of the compressor capacity is required. The operating pressure should be 0.1 MPa or more.
- 4) Use the N.C. type auto drain at the operating pressure of 0.15MPa or higher to prevent malfunction.

### Caution

- 1) Do not use the product with low air pressure (e.g. for blower). This product is dedicated for compressed air whose minimum operating pressure is specified depending on the equipment. If the product is operated at a pressure lower than the minimum operating pressure, it may cause deterioration in the performance or malfunction.

## Installation

### Warning

- 1) Do not drop or apply impact during transportation or installation. It will cause damage to the product and result in operation failure.
- 2) Do not install in areas of high humidity or high temperature. Operation outside of the product specification range may cause damage to the product or operation failure, or shorten the product life.
- 3) Connect the product ensuring the direction of arrow or "1"(IN) and "2"(OUT) ports for air direction or an arrow. Incorrect connections may cause malfunction.
- 4) Install with adequate space for maintenance beneath the product. Refer to [12. Dimensions] (page 19) for necessary space.
- 5) Install vertically so that outlet of drain is facing downward. It cannot be used in horizontal or upward direction as it may cause operation failure.

## Piping

### Warning

- 1) Before piping, perform flushing or cleaning of the piping, etc. to remove any cutting chips, cutting oil, solid foreign matter, etc. from the piping. Contamination of piping may cause damage or malfunction.
- 2) When screwing together pipes and fittings, etc., be certain that chips from the pipe threads and sealant do not get inside the pipe. When a sealant tape is used, leave 1.5 to 2 thread ridges exposed at the end of the threads.
- 3) Connect piping/fittings using the recommended torque while holding the female thread side tightly. Insufficient tightening torque can cause loose piping or sealing failure. Excess tightening torque may cause damage to threads. If the female side is not held while tightening, excessive force will be applied to the bracket directly, causing breakage.

Recommended tightening torque (Unit: N m)

Thread size	3/4	1
Torque	28 to 30	36 to 38

- 4) Before screwing-in an SMC fitting or S coupler, please refer to "Tightening the threaded portion of the connection thread" section of the Fitting & Tubing Precautions.
- 5) Do not apply torsion or bending moment other than the weight of the product itself. External piping needs to be supported separately as it may cause damage. Non-flexible piping like steel tube is susceptible to excessive moment load or vibration. Insert flexible tubes to prevent this.
- 6) Drain guide is not equipped with valve function. Be sure to connect piping for drain. No piping for drain allows the drain and compressed air to exhaust freely. Also, the piping should be performed with drain guide held by spanner to prevent breakage of bowl.
- 7) To make drain discharge piping for auto drain, connect pipes under the following conditions to avoid malfunction. Tube with a piping internal diameter of  $\phi 6.5$  ( $\phi 1/4$ " ) or above and a length of 5 m (200 inch) or less.
- 8) Pipework for auto drain discharge which rises higher than the auto drain outlet should be avoided. It may cause the auto drain operation to fail.

## Air Source

### Warning

- 1) Use clean air. Do not use compressed air containing chemicals, organic solvent, synthetic oil or corrosive gas as it may be cause of breakage of components or operation failure.
- 2) Air containing too much moisture may deteriorate the performance. Install the refrigerated air dryer or aftercooler before the micro mist separator.
- 3) Make sure that the supply pressure is not below the minimum operating pressure. If it is used at the minimum operating pressure or less, pressure resistance increases, leading to the decrease of operation life or operation failure.

### Caution

- 1) Install the mist separator AFM series or AM series as a pre-filter to the inlet of the product in order to avoid the clogging of early stage.

## Maintenance

### Warning

- 1) Release the pressure in the product to the atmosphere when replacing parts or removing piping.
- 2) Maintenance and checks should be done by following the procedure in the operation manual. Incorrect handling of the product may cause breakage or operation failure of the equipment or device.
- 3) Do not touch the product when operating at high temperature (40 to 60 °C). The operators may get burnt. Be sure to confirm that the temperature of the container or operating part is reduced to 40 °C or less to prevent burns.
- 4) On a product with an element service indicator, perform regular checks to find cracks, scratches, or other deterioration of the indicator window. If any crack, scratch, and other defect is observed, replace the element service indicator with new a one because such a defect may cause the product to be broken. Investigate and/or review the operating conditions if necessary.
- 5) Check for dirt in the bowl periodically. If any dirt is seen, replace with new bowl.
- 6) Open and close drain cock by hand. The use of tools can result in damage to the product.
- 7) Replace the element before 2 years passed from start of use or pressure drop (difference between the inlet pressure and outlet pressure) reaches 0.1MPa. Or if the element is broken.

### Caution

- 1) Check the element periodically and replace it with a new one if necessary. If it is found that outlet pressure drops or the flow is restricted, check the condition of the element.
- 2) For the N.C. type auto drain, when there is no pressure, condensate which does not operate the auto drain mechanism will remain in the bowl. It is recommended to release the residual condensate manually at the end of the working day.
- 3) Products with an element service indicator show a red indication as the element clogging progresses. Ensure that the element is replaced before the red indication reaches the upper limit.

## 2. Application

This product aims at eliminating oil aerosol and solid foreign matter in the air line.

## 3. Standard specifications

Model No.		AMD50	AMD60
Port size		3/4, 1	1
Fluid		Air	
Ambient and operating fluid temperature		-5 to 60 °C (No freezing)	
Proof pressure		1.5MPa	
Max. operating pressure		1.0MPa	
Min. operating pressure of auto drain	N.C.	0.15MPa	
	N.O.	0.1MPa	
Nominal filtration rating <sup>Note1)</sup>		0.01µm (99.9% filtered particle size)	
Outlet side oil aerosol concentration <sup>Note2)</sup>		0.1mg/m <sup>3</sup>	
Max. air flow capacity <sup>Note3)</sup>		2200L/min(ANR)	3700L/min(ANR)
Compressed air purity class <sup>Note4)</sup>		ISO8573-1:2010[1:7:2]	
Drain capacity		100cm <sup>3</sup>	
Bowl material		Stainless steel	
Weight		1.23kg	1.46kg

Note1) Conditions in accordance with [Test method ISO 12500-3:2009 compliant] in addition to the conditions above.

- Flow capacity, inlet pressure, and the amount of solid or liquid particles on the filter inlet side are stable.
- New element

Note2) Conditions in accordance with [Test method ISO 12500-1:2007 compliant] in addition to the conditions above.

- Oil aerosol concentration on the filter inlet side = 1 mg/m<sup>3</sup>
- Inlet air temperature: 25°C
- Flow capacity, inlet pressure, and the oil aerosol concentration on the filter inlet side are stable.
- New element

Note3) Inlet pressure: 0.7MPa Flow rate at 20°C, atmospheric pressure, and 65% of relative humidity.

Note4) Based on ISO8573-1:2010 Compressed air - Part1: Contaminants and purity classes.

The compressed air quality class on the inlet side is [2:7:3].



## 4. How to Order

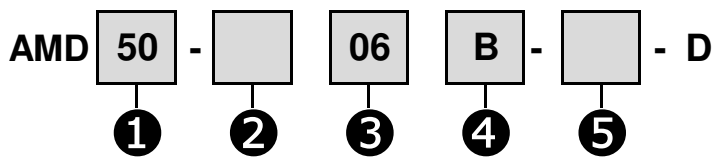

		Symbol	Description	①			
				Body size			
				50	60		
②	Thread type		Nil	Rc	●	●	
			N	NPT	●	●	
			F	G	●	●	
③	Port size		06	3/4	●	—	
			10	1	●	●	
④	Options	a Mounting		Nil	Without mounting option	●	●
				B	With bracket	●	●
		b Float type auto drain		Nil	Without auto drain	●	●
				C	N.C. (Normally closed) Drain port is closed when pressure is not supplied.	●	●
D	N.O. (Normally open) Drain port is open when pressure is not supplied.	●	●				
⑤	Semi-standard	c Drain port		Nil	With drain cock	●	●
				J	Drain guide 1/4	●	●
				W	With drain cock and barb fitting	●	●
		d Indicator		Nil	Without indicator	●	●
				L	With element service indicator	●	●
		e Flow direction		Nil	Flow direction: Left to right	●	●
				R	Flow direction: Right to left	●	●
		f Pressure unit Temperature unit		Nil	Pressure unit: MPa Temp. unit: °C	●	●
Z	Pressure unit: psi Temp. unit: °F			○ <sup>Note2)</sup>	○ <sup>Note2)</sup>		

Note1) ④Option and ⑤Semi-standard: Select one each for a to f.

Note2) ○: For NPT thread type only.

## 5. Construction / Options / Replacement parts

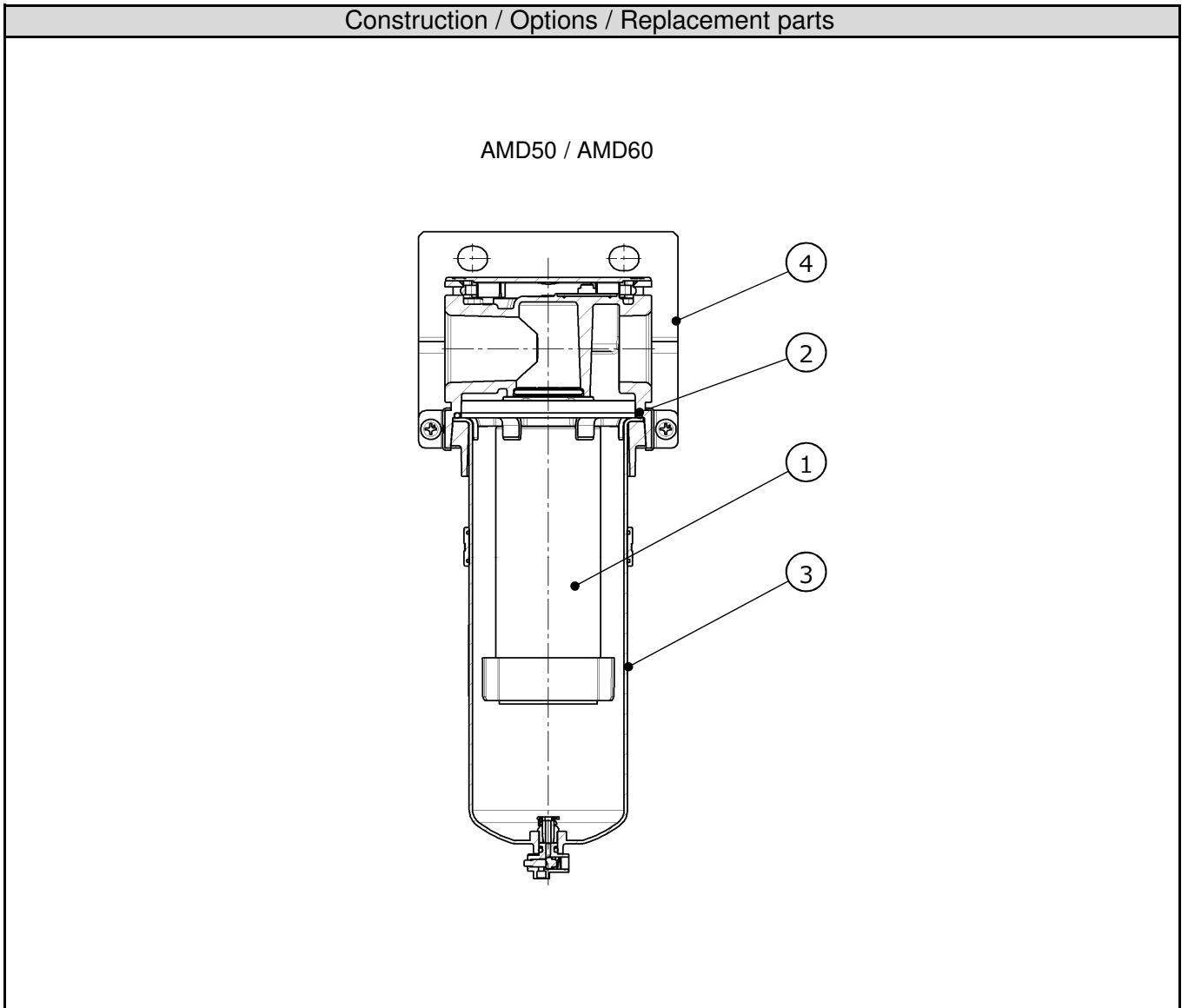

### Replacement parts

No.	Parts description	Part No.	
		AMD50	AMD60
①	Element	AMD54P-060AS	AMD64P-060AS
②	Bowl seal	AM54P-160S	
③	Bowl assembly	Refer to [6. Bowl assembly specifications] (P10 and P11).	
	Auto drain (N.C.)		
	Auto drain (N.O.)		

Note1) The numbers in the table and construction are consistent with the number in [10. How to Replace the Components] (P16 and 17) and [11. Disassembly Drawing](P18).

### Options

No.	Parts description	Part No.	
		AMD50	AMD60
④	Bracket assembly <sup>Note2)</sup>	AF54P-070AS	

Note1) Refer to the [7. Assembly of Optional parts] (P12) for mounting the bracket assembly.

Note2) Assembly of the mounting bracket (2 types) and set screw (2 pcs.).

## 6. Bowl assembly specifications

### 6-1. Bowl assembly for AMD50

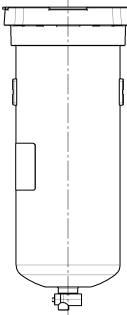
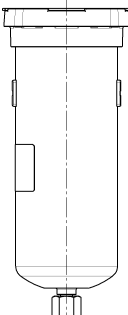
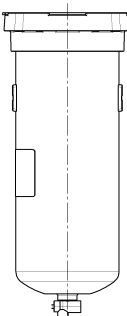
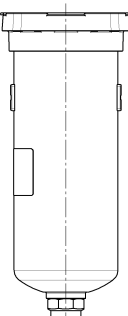
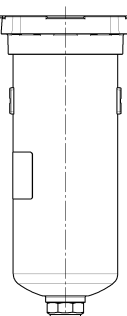
Option symbol	—	—														
Semi-standard symbol	—	J														
Appearance and Part No.	<b>Semi-standard: "-"</b> (Standard) <table border="1"> <thead> <tr> <th>Port thread type</th> <th>③Part No.</th> </tr> </thead> <tbody> <tr> <td>Rc</td> <td rowspan="3">AM54P-120AS</td> </tr> <tr> <td>G</td> </tr> <tr> <td>NPT</td> </tr> </tbody> </table> 	Port thread type	③Part No.	Rc	AM54P-120AS	G	NPT	<b>Semi-standard: "J"</b> <table border="1"> <thead> <tr> <th>Port thread type</th> <th>③Part No.</th> </tr> </thead> <tbody> <tr> <td>Rc</td> <td>AM54P-120AS-J</td> </tr> <tr> <td>G</td> <td>AM54P-F120AS-J</td> </tr> <tr> <td>NPT</td> <td>AM54P-N120AS-J</td> </tr> </tbody> </table> 	Port thread type	③Part No.	Rc	AM54P-120AS-J	G	AM54P-F120AS-J	NPT	AM54P-N120AS-J
	Port thread type	③Part No.														
Rc	AM54P-120AS															
G																
NPT																
Port thread type	③Part No.															
Rc	AM54P-120AS-J															
G	AM54P-F120AS-J															
NPT	AM54P-N120AS-J															
Option symbol	—	C <sup>Note1)</sup>														
Semi-standard symbol	W	—														
Appearance and Part No.	<b>Semi-standard: "W"</b> <table border="1"> <thead> <tr> <th>Port thread type</th> <th>③Part No.</th> </tr> </thead> <tbody> <tr> <td>Rc</td> <td rowspan="3">AM54P-120AS-W</td> </tr> <tr> <td>G</td> </tr> <tr> <td>NPT</td> </tr> </tbody> </table> 	Port thread type	③Part No.	Rc	AM54P-120AS-W	G	NPT	<b>Semi-standard: "C"</b> <table border="1"> <thead> <tr> <th>Port thread type</th> <th>③Part No.</th> </tr> </thead> <tbody> <tr> <td>Rc</td> <td rowspan="3">AM54P-120AS-C</td> </tr> <tr> <td>G</td> </tr> <tr> <td>NPT</td> <td>AM54P-N120AS-C</td> </tr> </tbody> </table> 	Port thread type	③Part No.	Rc	AM54P-120AS-C	G	NPT	AM54P-N120AS-C	
	Port thread type	③Part No.														
Rc	AM54P-120AS-W															
G																
NPT																
Port thread type	③Part No.															
Rc	AM54P-120AS-C															
G																
NPT		AM54P-N120AS-C														
Option symbol	D <sup>Note2)</sup>															
Semi-standard symbol	—															
Appearance and Part No.	<b>Semi-standard: "D"</b> <table border="1"> <thead> <tr> <th>Port thread type</th> <th>③Part No.</th> </tr> </thead> <tbody> <tr> <td>Rc</td> <td rowspan="2">AM54P-120AS-D</td> </tr> <tr> <td>G</td> </tr> <tr> <td>NPT</td> <td>AM54P-N120AS-D</td> </tr> </tbody> </table> 	Port thread type	③Part No.	Rc	AM54P-120AS-D	G	NPT	AM54P-N120AS-D	Note1) Minimum operating pressure is 0.15MPa. Note2) Minimum operating pressure is 0.1MPa. Note3) Part No.③ includes Bowl seal ②. Refer to [11. Disassembly Drawing ](P18). Note4) Refer to [4. How to Order] (P8) for option and semi-standard symbols.							
	Port thread type	③Part No.														
Rc	AM54P-120AS-D															
G																
NPT	AM54P-N120AS-D															

## 6-2. Bowl assembly for AMD60

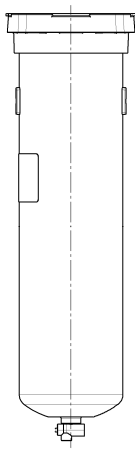
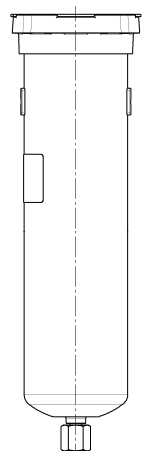
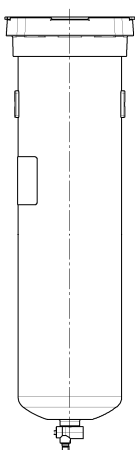
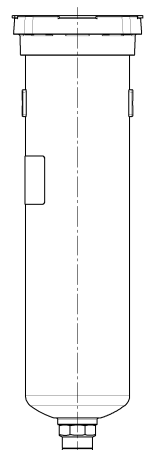
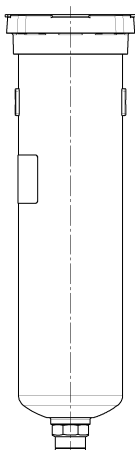
Option symbol	—	—														
Semi-standard symbol	—	J														
Appearance and Part No.	<p><b>Semi-standard: "-"</b> (Standard)</p> <table border="1"> <thead> <tr> <th>Port thread type</th> <th>③Part No.</th> </tr> </thead> <tbody> <tr> <td>Rc</td> <td rowspan="3">AM64P-120AS</td> </tr> <tr> <td>G</td> </tr> <tr> <td>NPT</td> </tr> </tbody> </table> 	Port thread type	③Part No.	Rc	AM64P-120AS	G	NPT	<p><b>Semi-standard: "J"</b></p> <table border="1"> <thead> <tr> <th>Port thread type</th> <th>③Part No.</th> </tr> </thead> <tbody> <tr> <td>Rc</td> <td>AM64P-120AS-J</td> </tr> <tr> <td>G</td> <td>AM64P-F120AS-J</td> </tr> <tr> <td>NPT</td> <td>AM64P-N120AS-J</td> </tr> </tbody> </table> 	Port thread type	③Part No.	Rc	AM64P-120AS-J	G	AM64P-F120AS-J	NPT	AM64P-N120AS-J
Port thread type	③Part No.															
Rc	AM64P-120AS															
G																
NPT																
Port thread type	③Part No.															
Rc	AM64P-120AS-J															
G	AM64P-F120AS-J															
NPT	AM64P-N120AS-J															
Option symbol	—	C <sup>Note1)</sup>														
Semi-standard symbol	W	—														
Appearance and Part No.	<p><b>Semi-standard: "W"</b></p> <table border="1"> <thead> <tr> <th>Port thread type</th> <th>③Part No.</th> </tr> </thead> <tbody> <tr> <td>Rc</td> <td rowspan="3">AM64P-120AS-W</td> </tr> <tr> <td>G</td> </tr> <tr> <td>NPT</td> </tr> </tbody> </table> 	Port thread type	③Part No.	Rc	AM64P-120AS-W	G	NPT	<p><b>Semi-standard: "C"</b></p> <table border="1"> <thead> <tr> <th>Port thread type</th> <th>③Part No.</th> </tr> </thead> <tbody> <tr> <td>Rc</td> <td rowspan="3">AM64P-120AS-C</td> </tr> <tr> <td>G</td> </tr> <tr> <td>NPT</td> <td>AM64P-N120AS-C</td> </tr> </tbody> </table> 	Port thread type	③Part No.	Rc	AM64P-120AS-C	G	NPT	AM64P-N120AS-C	
Port thread type	③Part No.															
Rc	AM64P-120AS-W															
G																
NPT																
Port thread type	③Part No.															
Rc	AM64P-120AS-C															
G																
NPT		AM64P-N120AS-C														
Option symbol	D <sup>Note2)</sup>															
Semi-standard symbol	—															
Appearance and Part No.	<p><b>Semi-standard: "D"</b></p> <table border="1"> <thead> <tr> <th>Port thread type</th> <th>③Part No.</th> </tr> </thead> <tbody> <tr> <td>Rc</td> <td rowspan="2">AM64P-120AS-D</td> </tr> <tr> <td>G</td> </tr> <tr> <td>NPT</td> <td>AM64P-N120AS-D</td> </tr> </tbody> </table> 	Port thread type	③Part No.	Rc	AM64P-120AS-D	G	NPT	AM64P-N120AS-D	<p>Note1) Minimum operating pressure is 0.15MPa.            Note2) Minimum operating pressure is 0.1MPa.            Note3) Part No.③ includes Bowl seal ②.            Refer to [11. Disassembly Drawing](P18).            Note4) Refer to [4. How to Order] (P8) for option and semi-standard symbols.</p>							
Port thread type	③Part No.															
Rc	AM64P-120AS-D															
G																
NPT	AM64P-N120AS-D															

## 7. Assembly of Optional parts

### Bracket

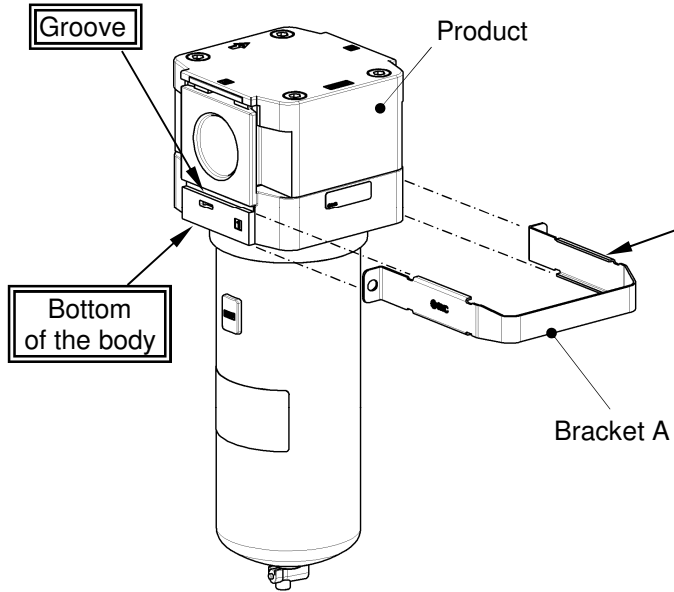

#### 1) Mounting of bracket A

Insert bracket A from the front side of the product so that the finger of the bracket A engages with the groove and the bottom of the body.

(see drawing on the left)

#### 2) Mounting of bracket B

Fix the bracket B with the set screw (2 pcs.) included in the package. Refer to the table below for the tightening torque.

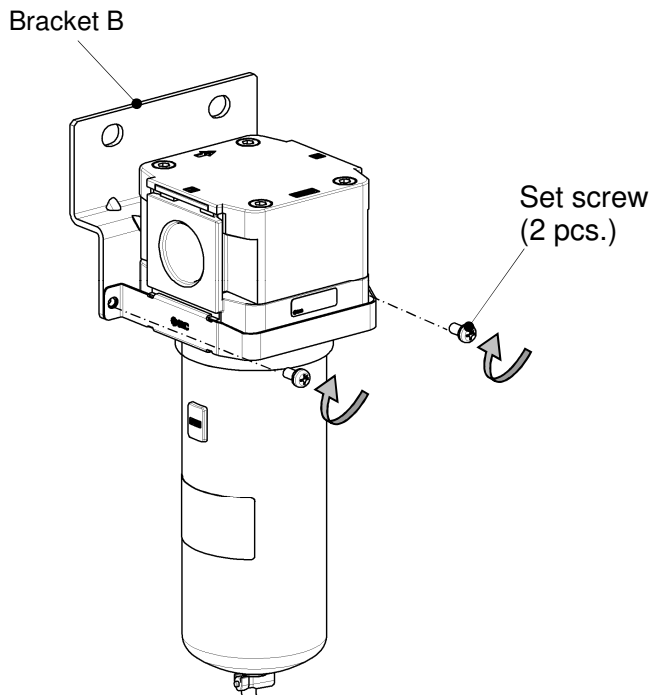

Model No.	Tools	Tightening torque
AMD50	Phillips screwdriver(+)	1.5±0.2 Nm
AMD60		

## 8. Operation and Adjustment

### 8-1. Discharge from the product with drain cock

- Pressurize the inside of the micro mist separator when discharging drain.  
Drain will not be discharged properly if not pressurized.

AMD50 / AMD60: Drain cock / With barb fitting (push type)

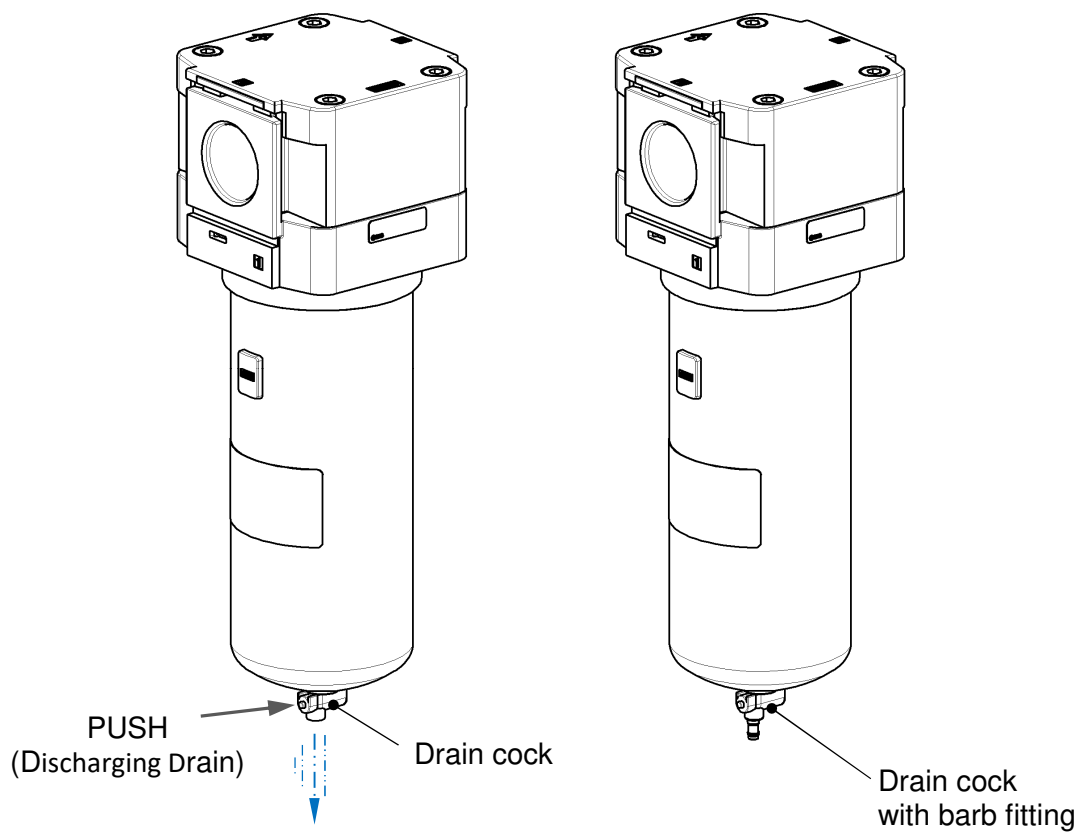

## 8-2. Manual drain discharge from the auto drain

- Pressurize the inside of the micro mist separator when discharging drain.  
Drain will not be discharged properly if not pressurized.
- To discharge the auto drain manually, follow the procedure below. After discharging the drain, rotate the cock to the opposite direction by hand to close the drain valve.  
Use of a tool can damage the product.

AMD50 / AMD60: Auto drain

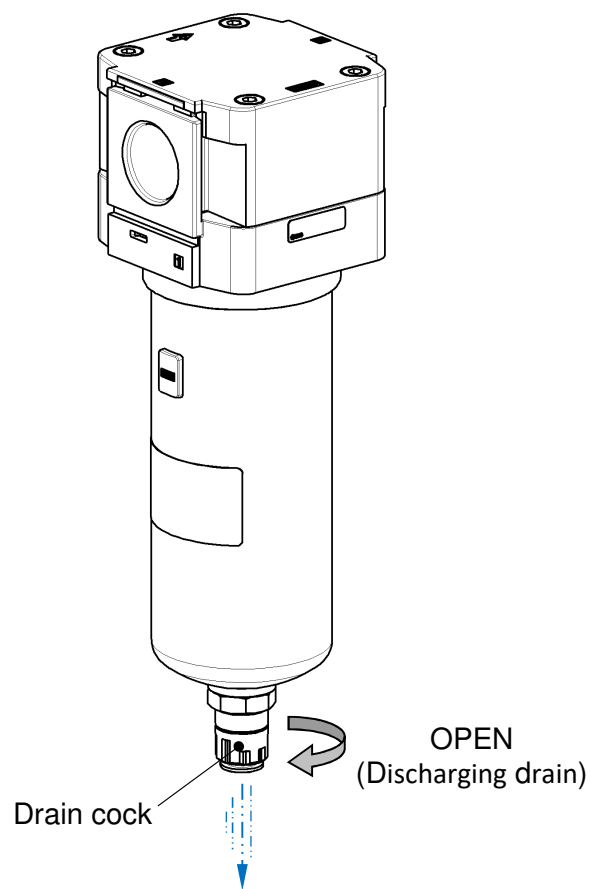

## 9. Troubleshooting

Refer to [10. How to Replace the Components](P16 and 17) and [11. Disassembly Drawing](P18).

Problem		Possible causes	Countermeasure	Page for reference
Category	Failure			
Flow rate	As pressure drop is large, fluid does not flow.	1. Clog of the element.	Replace the element.	P16 and 17
Air leakage	Air leaks between the body and bowl.	1. Breakage of bowl seal.	Replace the bowl seal. Apply grease to the bowl seal before assembling it. <sup>Note1)</sup>	P16
	Air leakage from the bowl.	1. Bowl is damaged.	Replace the bowl assembly.	P16
	Air leakage from the drain cock.	1. Foreign matter caught in the valve of the drain cock.	Open the drain cock for a few seconds for blowing.	P13
		2. The drain cock and bowl seat are damaged.	Replace the bowl assembly.	P16
	Drainage or air continues blowing out of the drain discharge of the float type auto drain.	1. Low supply pressure.	Check the minimum operating pressure of the auto drain.	P7 P10 to 11
		2. The product is not mounted correctly.	Install the drain exhaust so that it will face vertically downward.	-
		3. Foreign matter is caught at the main valve of the auto drain.	Remove the dust by manual drain discharge.	P14
		4. Main valve of the auto drain is broken.	Replace the bowl assembly.	P16
		5. Drain piping is long, or I.D. of the piping is small. (Back pressure is applied.)	Be sure to connect the appropriate piping for drain.	P5
		6. Drain exhaust and bowl seat are broken.	Replace the bowl assembly.	P16
Drainage	Drain is not discharging when the drain cock opens.	1. Blockage of outlet of the drain cock due to solid foreign matter etc.	Wash the bowl interior to remove foreign matters and oil content. If the condition does not improve after washing, replace the bowl assembly.	P6 P16
	Too much drain comes from the piping of outlet side.	1. Drain level reaches the bottom of the element.	Open the drain cock for draining and replace the element.	P13 to 14 P16 to 17

Note1) Fluorine grease is recommended when applying additional grease.



# 10. How to Replace the Components

## Warning

Before replacement, make sure that no pressure remains in the equipment.

After replacement, confirm that the product satisfies specific functions and no external leakage occurs before operating it.

### 10-1. Bowl assembly Replacement

Model No.	Work classification	Work step	Tools	Criteria	
AMD50 AMD60	Disassembly	1) Remove the bowl assembly from the product. Remove four mounting screws while supporting the flange by hand, and lower the flange up to the stopper.	AMD50/AMD60 Hexagon wrench key (Nominal size: 5)	—	
		2) Rotate bowl assembly by around 10° in the arrow direction, then remove the bowl assembly from the body.	—	—	
		3) Remove the bowl seal and element.	—	—	
	Assembly	4) Install the element and bowl seal in the bowl assembly.	—	—	
		5) Insert the fingers (two locations) of the bowl into the notches (two locations) of the body by aligning them with each other, and turn the bowl assembly by around 10° in the arrow direction. Engage both fingers (two locations) of the bowl with the body.	—	—	
		6) Install the flange to the body, temporarily tighten four mounting screws, and then tighten them diagonally and evenly to secure the flange.	AMD50/AMD60 Hexagon wrench key (Nominal size: 5)	Tightening torque: <table border="1"> <tr> <td>AMD50</td> <td rowspan="2">3.5±0.3Nm</td> </tr> <tr> <td>AMD60</td> </tr> </table>	AMD50
AMD50	3.5±0.3Nm				
AMD60					

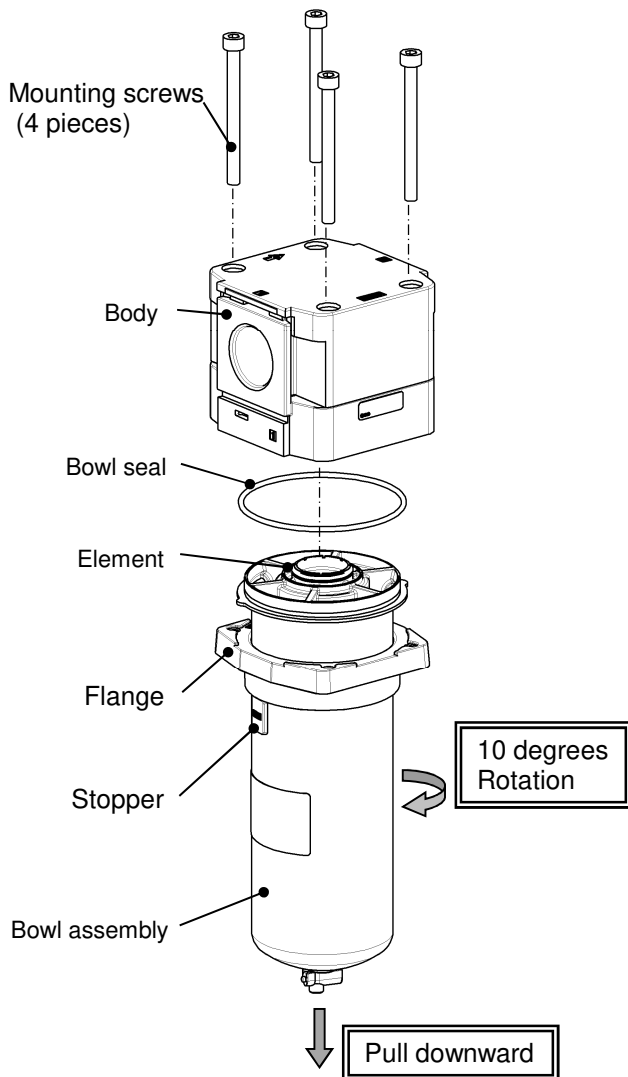

#### Assembly 5. Engagement condition of finger part of bowl

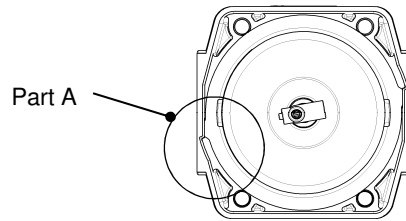

Align the notch groove with the finger of the bowl (Part A).

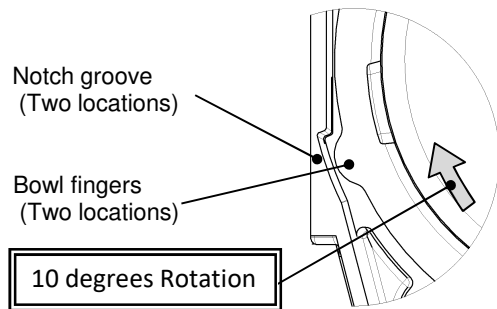

Engage the fingers of the bowl with the body (Part A).

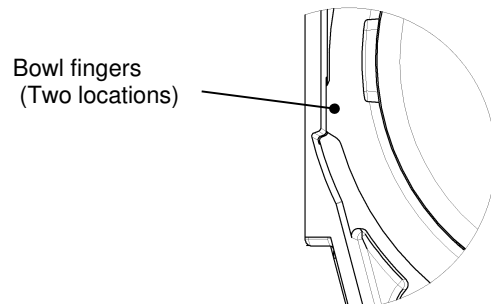

## 10-2. Element Replacement

Model No.	Work classification	Work step	Tools	Criteria
AMD50 AMD60	Disassembly	1) Remove the bowl assembly by referring to the section [10-1. Bowl assembly Replacement] (P16).	—	—
	Assembly	2) Install the replacing element and bowl seal in the bowl assembly. Mount the bowl assembly by referring to the section [10-1. Bowl assembly Replacement] (P16).	—	—

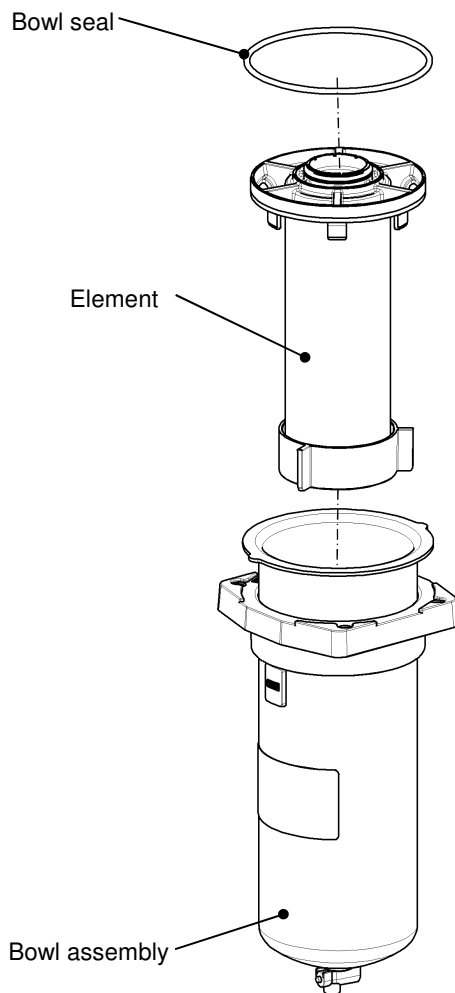

# 11. Disassembly Drawing

AMD50 / AMD60

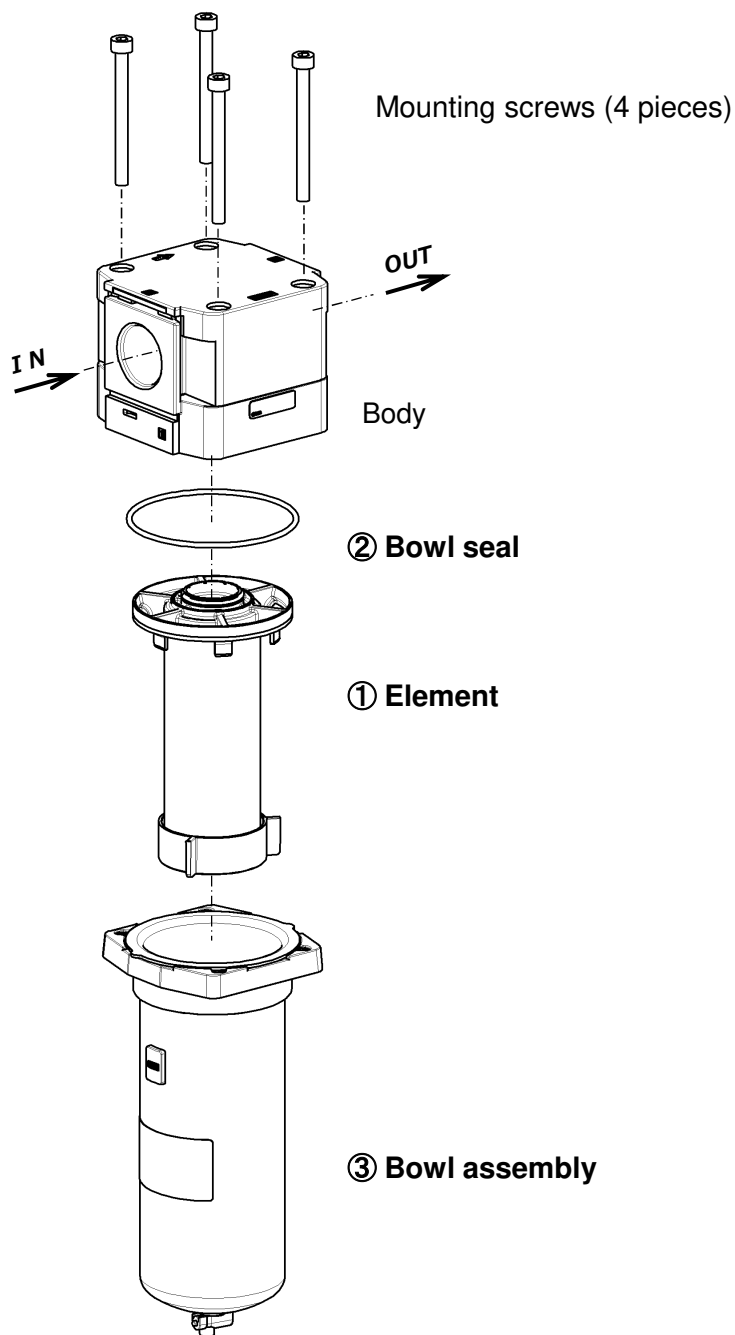

## 12. Dimensions

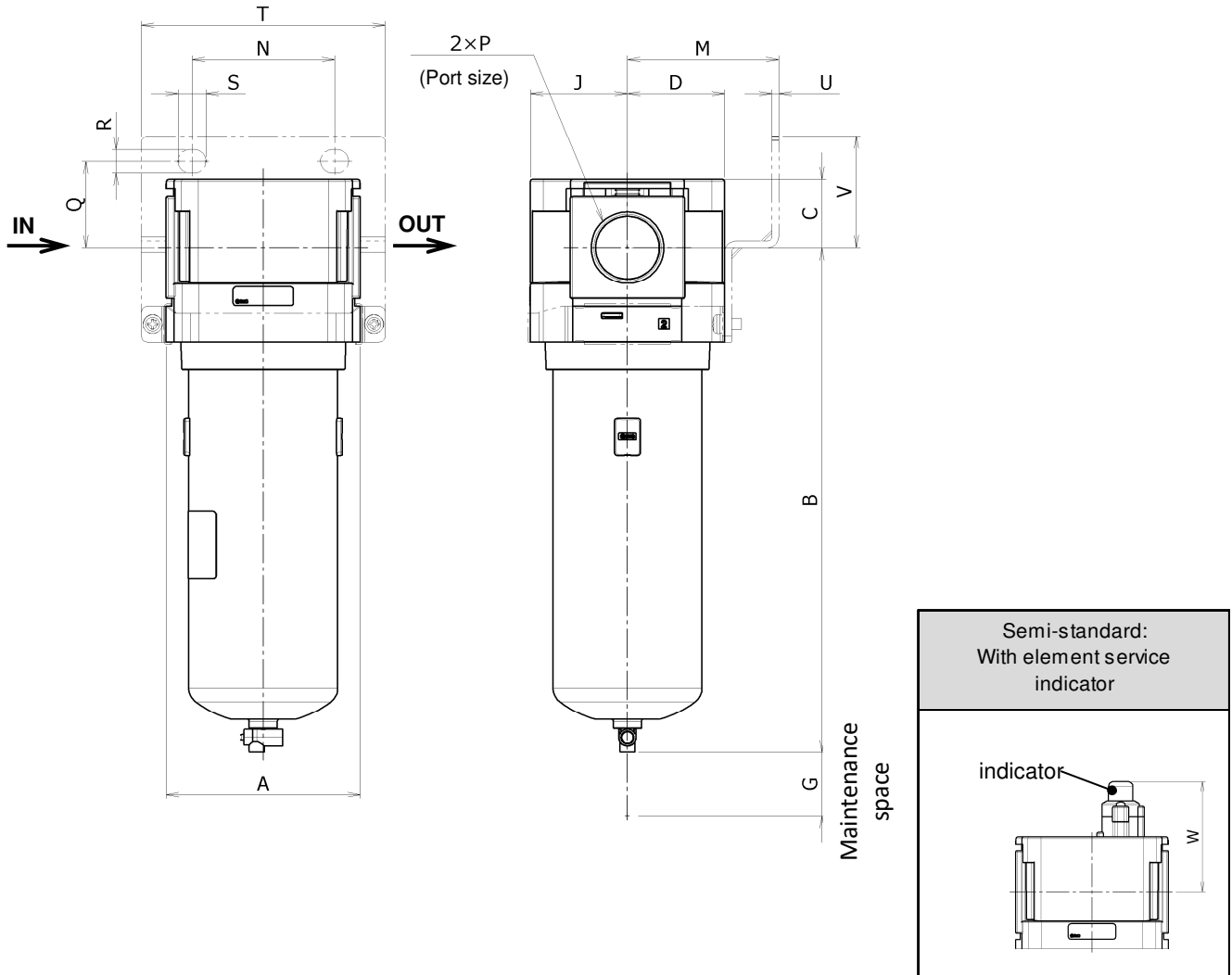

Model No.	Standard specifications						Option specifications									
							Bracket mount									
	P	A	B	C	D	G	J	M	N	Q	R	S	T	U	V	B
AMD50	3/4 · 1	90	237.7	32	45	30	45	70	66	40.5	11	13	113	3.2	52.5	259.2
AMD60	1	90	314.8	32	45	30	45	70	66	40.5	11	13	113	3.2	52.5	336.3

Model No.	Semi-standard specifications		
	SUS bowl		With indicator
	Barb fitting	With drain guide	
	B	B	W
AMD50	246.2	244.5	64.3
AMD60	323.3	321.6	64.3

Revision history
------------------

# SMC Corporation

4-14-1, Sotokanda, Chiyoda-ku, Tokyo 101-0021 JAPAN

Tel: + 81 3 5207 8249 Fax: +81 3 5298 5362

URL <https://www.smcworld.com>