



Operation Manual

PRODUCT NAME

Micro Mist Separator

MODEL / Series / Product Number

AFD20-(F,N)01 ~ (F,N)02(B,C)(-2,6,C,J,L,R,Z)-D

AFD30-(F,N)02 ~ (F,N)03(B,C,D)(-2,6,8,J,L,R,W,Z)-D

AFD40-(F,N)02 ~ (F,N)04(B,C,D)(-2,6,8,J,L,R,W,Z)-D

AFD40-(F,N)06(B,C,D)(-2,6,8,J,R,W,Z)-D

SMC Corporation

Contents

	Page
1. Safety Instructions	2-7
2. Application	8
3. Standard Specifications	8
4. How to Order	9
5. Structural Drawing, Option and Replacement Parts	10
6. Bowl Assembly Specifications	11-18
7. Assembly of Optional Parts	19
8. Operation and Adjustment	20-21
9. Trouble Shooting	22
10. How to Replace the Components	23-26
10-1. Bowl Assembly Replacement	23-24
10-2. Element Replacement	25-26
11. Disassembly Drawing	27
12. Dimensions	28



Safety Instructions

These safety instructions are intended to prevent hazardous situations and/or equipment damage. These instructions indicate the level of potential hazard with the labels of "Caution," "Warning" or "Danger." They are all important notes for safety and must be followed in addition to International Standards (ISO/IEC)*1), and other safety regulations.

*1) ISO 4414: Pneumatic fluid power -- General rules relating to systems.

ISO 4413: Hydraulic fluid power -- General rules relating to systems.

IEC 60204-1: Safety of machinery -- Electrical equipment of machines .(Part 1: General requirements)

ISO 10218: Manipulating industrial robots -Safety.

etc.



Caution

Caution indicates a hazard with a low level of risk which, if not avoided, could result in minor or moderate injury.



Warning

Warning indicates a hazard with a medium level of risk which, if not avoided, could result in death or serious injury.



Danger

Danger indicates a hazard with a high level of risk which, if not avoided, will result in death or serious injury.

Warning

1. The compatibility of the product is the responsibility of the person who designs the equipment or decides its specifications.

Since the product specified here is used under various operating conditions, its compatibility with specific equipment must be decided by the person who designs the equipment or decides its specifications based on necessary analysis and test results.

The expected performance and safety assurance of the equipment will be the responsibility of the person who has determined its compatibility with the product.

This person should also continuously review all specifications of the product referring to its latest catalog information, with a view to giving due consideration to any possibility of equipment failure when configuring the equipment.

2. Only personnel with appropriate training should operate machinery and equipment.

The product specified here may become unsafe if handled incorrectly.

The assembly, operation and maintenance of machines or equipment including our products must be performed by an operator who is appropriately trained and experienced.

3. Do not service or attempt to remove product and machinery/equipment until safety is confirmed.

1. The inspection and maintenance of machinery/equipment should only be performed after measures to prevent falling or runaway of the driven objects have been confirmed.

2. When the product is to be removed, confirm that the safety measures as mentioned above are implemented and the power from any appropriate source is cut, and read and understand the specific product precautions of all relevant products carefully.

3. Before machinery/equipment is restarted, take measures to prevent unexpected operation and malfunction.

4. Contact SMC beforehand and take special consideration of safety measures if the product is to be used in any of the following conditions.

1. Conditions and environments outside of the given specifications, or use outdoors or in a place exposed to direct sunlight.

2. Installation on equipment in conjunction with atomic energy, railways, air navigation, space, shipping, vehicles, military, medical treatment, combustion and recreation, or equipment in contact with food and beverages, emergency stop circuits, clutch and brake circuits in press applications, safety equipment or other applications unsuitable for the standard specifications described in the product catalog.

3. An application which could have negative effects on people, property, or animals requiring special safety analysis.

4. Use in an interlock circuit, which requires the provision of double interlock for possible failure by using a mechanical protective function, and periodical checks to confirm proper operation.



Safety Instructions

Caution

The product is provided for use in manufacturing industries.

The product herein described is basically provided for peaceful use in manufacturing industries.

If considering using the product in other industries, consult SMC beforehand and exchange specifications or a contract if necessary.

If anything is unclear, contact your nearest sales branch.

Limited warranty and Disclaimer/Compliance Requirements

The product used is subject to the following “Limited warranty and Disclaimer” and “Compliance Requirements”.

Read and accept them before using the product.

Limited warranty and Disclaimer

1. The warranty period of the product is 1 year in service or 1.5 years after the product is delivered, whichever is first.*2)

Also, the product may have specified durability, running distance or replacement parts. Please consult your nearest sales branch.

2. For any failure or damage reported within the warranty period which is clearly our responsibility, a replacement product or necessary parts will be provided.

This limited warranty applies only to our product independently, and not to any other damage incurred due to the failure of the product.

3. Prior to using SMC products, please read and understand the warranty terms and disclaimers noted in the specified catalog for the particular products.

*2) Vacuum pads are excluded from this 1 year warranty.

A vacuum pad is a consumable part, so it is warranted for a year after it is delivered.

Also, even within the warranty period, the wear of a product due to the use of the vacuum pad or failure due to the deterioration of rubber material are not covered by the limited warranty.

Compliance Requirements

1. The use of SMC products with production equipment for the manufacture of weapons of mass destruction(WMD) or any other weapon is strictly prohibited.

2. The exports of SMC products or technology from one country to another are governed by the relevant security laws and regulation of the countries involved in the transaction. Prior to the shipment of a SMC product to another country, assure that all local rules governing that export are known and followed.

Caution

SMC products are not intended for use as instruments for legal metrology.

Measurement instruments that SMC manufactures or sells have not been qualified by type approval tests relevant to the metrology (measurement) laws of each country.

Therefore, SMC products cannot be used for business or certification ordained by the metrology (measurement) laws of each country.

Precautions for Design

Warning

- (1) Consult SMC if no leakage is allowed due to the environment, or if the operating fluid is not air.
- (2) Polycarbonate resin is used for the external parts including the bowl. Organic solvents including thinner, acetone, alcohol and ethylene chloride; chemicals including sulphuric acid, nitric acid and hydrochloric acid; cutting oil, synthetic oils, ester-based compressor oil, alkali, kerosene, gasoline, lock material of screw are harmful. Do not use the product where these are present.

Chemical resistance of polycarbonate and nylon bowl

Type	Chemical name	Application examples	Material	
			Polycarbonate	Nylon
Acid	Hydrochloric acid Sulfuric acid Phosphoric acid Chromic acid	Acid washing liquid for metals	△	×
Alkaline	Sodium hydroxide (Caustic soda) Potash Calcium hydroxide (Slack lime) Ammonia water Carbotane of soda	Degreasing of metals Industrial salts Water-soluble cutting oil	×	○
Inorganic salts	Sodium sulfide Potassium nitrate Sulfate of soda	-	×	△
Chlorine solvents	Carbon tetrachloride Chloroform Ethylene chloride Methylene chloride	Cleaning liquid for metals Printing ink Dilution	×	△
Aromatic series	Benzene Toluene Paint thinner	Coatings Dry cleaning	×	△
Ketone	Acetone Methyl ethyl ketone Cyclohexane	Photographic film Dry cleaning Textile industries	×	×
Alcohol	Ethyl alcohol IPA Methyl alcohol	Antifreeze Adhesives	△	×
Oil	Gasoline Kerosene	-	×	○
Ester	Phthalic acid dimethyl Phthalic acid diethyl Acetic acid	Synthetic oil Anti-rust additives	×	○
Ether	Methyl ether Ethyl ether	Brake oil additives	×	○
Amino	Methyl amino	Cutting oil Brake oil additives Rubber accelerator	×	×
Others	Thread-lock fluid Sea water Leak tester	-	×	△

○: Essentially safe. △: Some effects may occur. ×: Effects will occur.

Note1) When the above factors are present or there is some doubt, use a metal bowl for safety.

Note2) The display window of the element service indicator of semi standard products is made of nylon.

(3) Avoid the application where charge and discharge of pressure to/from a standard bowl is switched frequently. This may damage the bowl. A metal bowl is recommended in these cases.

(4) Shield from ultra violet light and radiation with protective cover.

**Caution**

- (1) Please install the product in a location where pulsation is unlikely to occur. When the difference between the inside and outside exceeds 0.1MPa, the element might be broken.
- (2) AD27-D with auto drain may have leakage of accumulated drain during pressure exhaust (this leakage is allowed in their constructions and not considered failure). Be sure to connect piping for drain.

Selection**Warning**

- (1) Grease used on the internal sliding parts and seals may flow to the outlet side. If this is not acceptable, please consult SMC.
- (2) N.O. type auto drain should be operated under the following conditions to avoid malfunction.
Operating compressor: 0.75 kW or more, Discharged flow rate: 100 L/min (ANR) or more
When using 2 or more auto drains, multiply the value above by the number of auto drains to find the capacity of the compressors you will need. For example, when using 2 auto drains, 1.5 kW (200 L/min (ANR)) of the compressor capacity is required. The operating pressure should be 0.1 MPa or more.
- (3) N.C. type auto drain should be operated under the following conditions to avoid malfunction.
Operating pressure for AD27: 0.1 MPa or more, for AD37 and AD47: 0.15 MPa or more.

**Caution**

- (1) Do not allow the fluid flow more than the rated flow rate. If the rated flow rate is momentarily exceeded, it may cause splashing of drainage and oil on the outlet side, and damage to the equipment.
- (2) Do not use the product with low air pressure (e.g. for blower). The product is for compressed air that the minimum operating pressure is specified depending on the equipment. If it is operated with the pressure lower than the minimum operating pressure, it may cause deterioration in the performance or operation failure.

Installation**Warning**

- (1) Do not drop or apply impact during transportation or installation. It will cause damage to the product and result in operation failure.
- (2) Do not install in areas of high humidity or high temperature. Operation outside of the product specification range may cause damage to the product or operation failure, or shorten the product life.
- (3) Connect the product ensuring the direction of "1"(IN) and "2"(OUT) for air direction and indicated arrow. Incorrect connections may cause malfunction.
- (4) Install with adequate space for maintenance beneath the product. Refer to the section [12. Dimensions] (P28) for necessary space.
- (5) Install vertically so that outlet of drain is downward. It cannot be used in horizontal or upward direction as it may cause operation failure.

Piping

Warning

- (1) Before piping is connected, it should be thoroughly blown out with air (flushing) or washed to remove chips, cutting oil and solid foreign material from inside the pipe. Contamination of piping may cause damage or malfunction.
- (2) When screwing together pipes and fittings, etc., be certain that chips from the pipe threads and sealant do not get inside the pipe. When a sealant tape is used, leave 1.5 to 2 thread ridges exposed at the end of the threads.
- (3) Connect piping/fittings using the recommended torque while holding the female thread side tightly. Insufficient tightening torque leads to cause of loosening or sealing failure, and excessive tightening torque leads to cause of breakage of screws. Tightening without holding female thread applies an excessive force to the bracket directly, leading to breakage.

Recommended tightening torque					Unit: N m
Thread size	1/8	1/4	3/8	1/2	3/4
Torque	7 to 9	12 to 14	22 to 24	28 to 30	28 to 30

- (4) Before using an SMC fitting and S coupler, please refer to "Tightening the threaded portion of the connection thread" of the Fittings & Tubing Precautions.
- (5) Do not apply torsion or bending moment other than the weight of the product itself. External piping needs to be supported separately as it may cause breakage. Non-flexible piping like steel tube is susceptible to excessive moment load or vibration. Insert flexible tubes to prevent this.
- (6) Drain guide is not equipped with valve function. Be sure to connect piping for drain. No piping for drain allows the drain and compressed air to exhaust freely. Also, the piping installation should be performed with drain guide held by spanner to prevent breakage of bowl.
- (7) The piping for drain from auto drain should be connected under the following requirements to avoid operating failure.
Tubing for AD27-D: I.D. $\phi 2.5$ ($\phi 3/32$ ") or larger, Length 5 m (200 inch) or shorter
Tubing for AD37, 47(N)-D: I.D. $\phi 4$ ($\phi 3/16$ ") or larger, Length 5 m (200 inch) or shorter
Tubing for AD38, 48(N)-D: I.D. $\phi 6.5$ ($\phi 1/4$ ") or larger, Length 5 m (200 inch) or shorter

Air Source

Warning

- (1) Use clean air. Do not use compressed air containing chemicals, organic solvent, synthetic oil or corrosive gas as it may be cause of breakage of components or operation failure.
- (2) Air containing too much moisture may cause malfunction. Install an air drier or aftercooler before the micro mist separator.

Caution

- (1) Do not install the product to the inlet of the dryer. It may cause the clogging of early stage.
- (2) Install the mist separator AFM series as a pre-filter to the inlet of the micro mist separator in order to avoid the clogging of early stage.

Handling Precautions

Warning

- (1) Element service indicator (semi-standard: L) is used to check the differential pressure between IN and OUT ports. When the differential pressure exceeds 0.025 Mpa, the element service indicator may start even when the element is in initial state.
- (2) When adjusting the flow rate of the product with an element service indicator, adjust the flow rate from minimum to maximum. When the flow rate exceeds the maximum value, readjust the flow rate from zero.
- (3) As the element goes through its service life and begins to clog, the red part of the element service indicator appears. Ensure that the element is replaced before the red indication reaches the upper level.

Maintenance

Warning

- (1) Release the pressure in the product to the atmosphere when replacing parts or removing piping.
- (2) Maintenance and checks should be done by following the procedure in this operation manual. Incorrect handling of the product may cause breakage or operation failure of the equipment or device.
- (3) Perform periodical check to find cracks, flaws or other deterioration on resin bowl. If any of these appear, replace with a new or metal bowl. Otherwise, breakage may occur. Investigate and/or review the operating conditions if necessary.
- (4) Check for dirt in resin bowl periodically. If any dirt is seen, replace with new bowl. If removing dirt by washing the resin bowl, never use washing material other than neutral detergent. Otherwise, the bowl is damaged.
- (5) Open and close the drain cock manually. The use of tools can result in damage to the product.
- (6) Replace the element every 2 years or when the pressure drop at the output pressure from initial operation becomes 0.1 MPa, whichever comes first, to prevent damage to the element.
- (7) Discharge drain from the bowl before it reaches the element assembly. Refer to the section [8. Operation and Adjustment] (P20-21) for discharging of drain.

Caution

- (1) Check the element periodically and replace it with a new one if necessary. If it is found that outlet pressure drops lower than the normal condition or the flow is restricted during operation, check the condition of the element.
- (2) For the N.C. type auto drain, when there is no pressure, drain which does not operate the auto drain mechanism will remain in the bowl. It is recommended to release the residual drain manually at the end of the working day.

2. Application

This product aims at eliminating oil and solid foreign matter in the air line.

3. Standard Specifications

Model		AFD20-D	AFD30-D	AFD40-D	AFD40-06-D
Port size		1/8, 1/4	1/4, 3/8	1/4, 3/8, 1/2	3/4
Fluid		Air			
Ambient and fluid temperature		-5 to 60 °C (with no freezing)			
Proof pressure		1.5 MPa			
Max. operating pressure		1.0 MPa			
Min. operating pressure		0.05 MPa			
Min. operating pressure of auto drain	N.C.	0.1 MPa	0.15 MPa		
	N.O.	—	0.1 MPa		
Max. air flow capacity ^{Note 1)}		120 L/min(ANR)	240 L/min(ANR)	600 L/min(ANR)	
Filtration rating		0.01 µm (99.9% filtered particle size)			
Outlet side oil mist concentration		Max. 0.1 mg/m ³ (ANR) [before the saturation of oil: 0.01 mg/m ³ (ANR) or less ≐ 0.008 ppm]			
Compressed air quality class ^{Note 2)}		ISO8573-1:2010 [1:7:2]			
Drain capacity		8 cm ³	25 cm ³	45 cm ³	
Bowl material		Polycarbonate			
Bowl guard		Semi-standard (Steel)	Standard (Polycarbonate)		
Weight		0.10 kg	0.18 kg	0.37 kg	0.40 kg

Note 1) When the mist separator inlet pressure is: 0.7 Mpa; at 20°C, atmospheric pressure, and relative humidity of 65%.

The maximum air flow capacity varies depending on the inlet pressure. Keep the air flow below the maximum air flow capacity to prevent an outflow of lubricant to the outlet side.

Note 2) Based on ISO8573-1:2010 Compressed air - Part 1: Contaminants and purity classes.

The compressed air quality class on the inlet side is [3:7:3].

4. How to Order

AFD **30** - **□** **03** **B** - **□** - D

1
2
3
4
5

		Symbol	Description	1				
				Body size				
				20	30	40		
2	Thread type	Nil	Rc	●	●	●		
		N	NPT	●	●	●		
		F	G	●	●	●		
3	Port size	01	1/8	●	—	—		
		02	1/4	●	●	●		
		03	3/8	—	●	●		
		04	1/2	—	—	●		
		06	3/4	—	—	●		
4	Option	a	Mounting	Nil	Without mounting option	●	●	●
				B	With bracket	●	●	●
	b	Float type auto drain	Nil	Without auto drain	●	●	●	
			C	N.C. (Normally closed) Drain port is closed when pressure is not supplied.	●	●	●	
			D	N.O. (Normally opened) Drain port is opened when pressure is not supplied.	—	●	●	
5	Semi-standard	c	Bowl	Nil	Polycarbonate bowl	●	●	●
				2	Metal bowl	●	●	●
				6	Nylon bowl	●	●	●
				8	Metal bowl with level gauge	—	●	●
				C	With bowl guard	●	—	—
				6C	With bowl guard (Nylon bowl)	●	—	—
				d	Indicator	Nil	Without indicator	●
		L	With element service indicator			●	●	● Note3)
		e	Drain port	Nil	With drain cock	●	●	●
				J	Drain guide 1/8	●	-	-
					Drain guide 1/4	-	●	●
		W	Drain cock with barb fitting	-	●	●		
		f	Flow direction	Nil	Flow direction: Left to right	●	●	●
				R	Flow direction: Right to left	●	●	●
		g	Pressure unit Temp. unit	Nil	Pressure unit: MPa Temp. unit: °C	●	●	●
Z	Pressure unit: psi Temp. unit: °F			○ Note 2)	○ Note 2)	○ Note 2)		

Note 1) 4 Option and 5 Semi-standard: Select one each for a to f.

Note 2) ○: For NPT thread type only.

Note 3) Port size "06" is not applicable.

5. Structural Drawing, Option and Replacement Parts

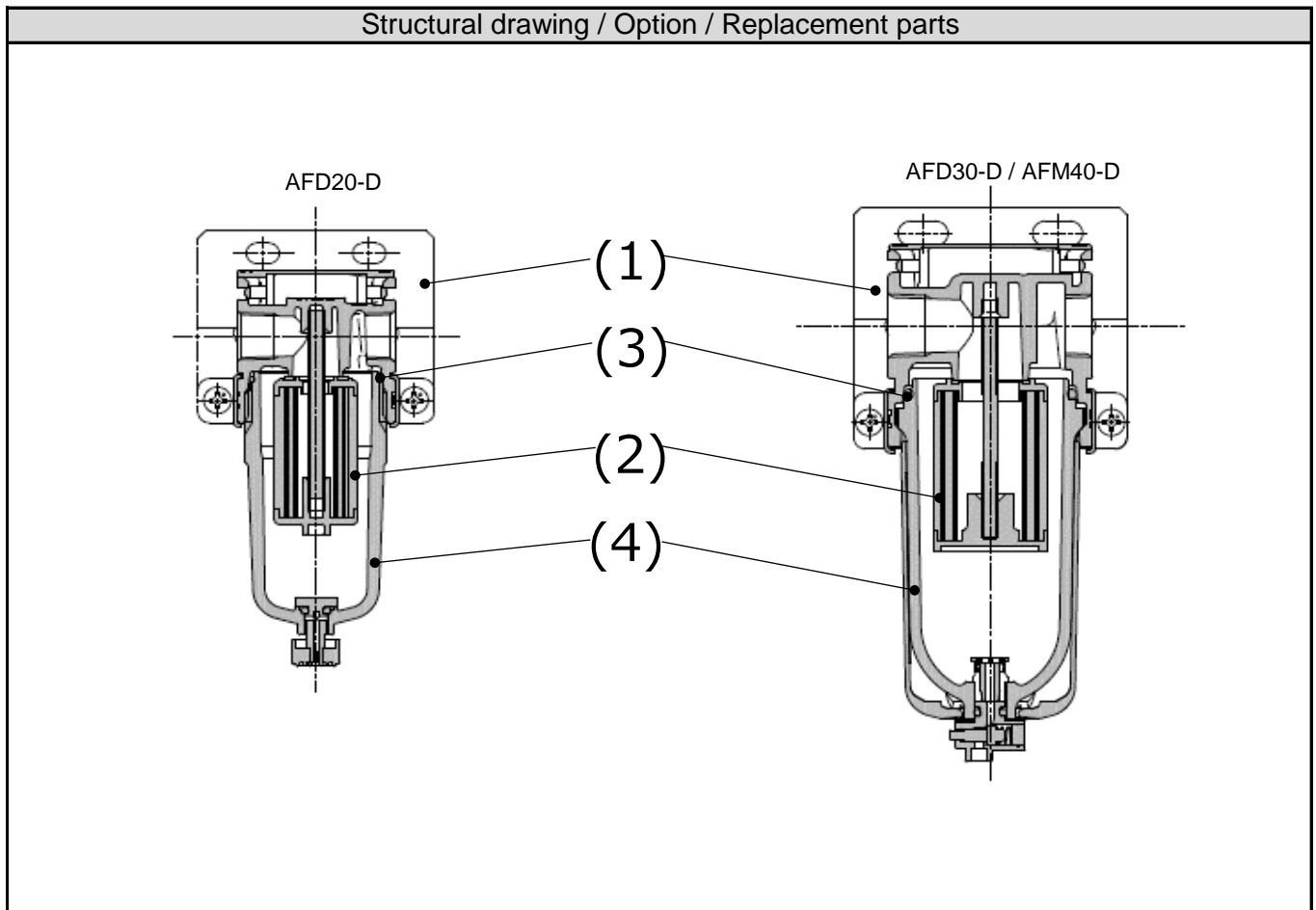

Option

No.	Part name	Part No.			
		AFD20-D	AFD30-D	AFD40-D	AFD40-06-D
(1)	Bracket assembly ^{Note 2)}	AF24P-070AS	AF34P-070AS	AF44P-070AS	AF49P-070AS

Note 1) The number in the table and structural drawing is consistent with the number in the sections [10. How to Replace the Components] (P23-26) and [11. Disassembly Drawing] (P27).

Note 2) Assembly of 2 types of bracket and 2 set screws.

Replacement Parts

No.	Part name	Part No.			
		AFD20-D	AFD30-D	AFD40-D	AFD40-06-D
(2)	Element assembly	AFD20P-060AS	AFD30P-060AS	AFD40P-060AS	
(3)	Bowl seal	C2SFP-260S	C32FP-260S	C42FP-260S	
(4)	Bowl assembly	Refer to the section [6. Bowl assembly specifications] (P11-P18).			
	Auto drain (N.C.)				
	Auto drain (N.O.)				

Note 1) The number in the table and structural drawing is consistent with the number in the sections [10. How to Replace the Components] (P23-26) and [11. Disassembly Drawing] (P27).

6. Bowl Assembly Specifications

6-1. Bowl assembly / auto drain for AFD20-D

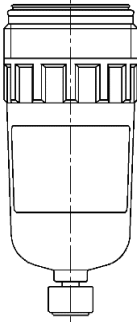
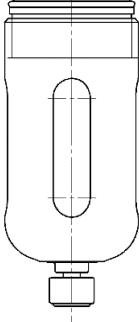
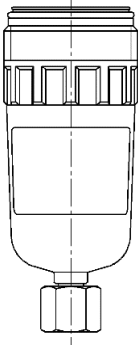
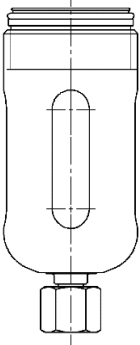
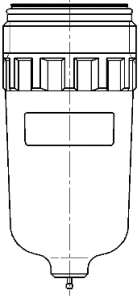
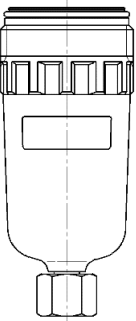
Option symbol	—		—	
Semi-standard symbol	—	6	C	6C
Appearance and part No.	Semi-standard: - (Standard)		Semi-standard: C	
	Piping port thread type	(4) Part No.	Piping port thread type	(4) Part No.
	Rc	C2SF-D	Rc	C2SF-C-D
	G	C2SF(Z)-D	G	C2SF-C(Z)-D
Semi-standard: 6		Semi-standard: 6C		
Piping port thread type	(4) Part No.	Piping port thread type	(4) Part No.	
Rc	C2SF-6-A	Rc	C2SF-6C-A	
G	C2SF-6(Z)-A	G	C2SF-6C(Z)-A	
NPT	C2SF-6(Z)-A	NPT	C2SF-6C(Z)-A	
				
Option symbol	—		—	
Semi-standard symbol	J	6J	CJ	6CJ
Appearance and part No.	Semi-standard: J		Semi-standard: CJ	
	Piping port thread type	(4) Part No.	Piping port thread type	(4) Part No.
	Rc	C2SF-J-D	Rc	C2SF-CJ-D
	G	C2SFF-J-D	G	C2SFF-CJ-D
Semi-standard: 6J		Semi-standard: 6CJ		
Piping port thread type	(4) Part No.	Piping port thread type	(4) Part No.	
Rc	C2SF-6J-A	Rc	C2SF-6CJ-A	
G	C2SFF-6J-A	G	C2SFF-6CJ-A	
NPT	C2SFN-6J(Z)-A	NPT	C2SFN-6CJ(Z)-A	
				
Option symbol	—		—	
Semi-standard symbol	2		2J	
Appearance and part No.	Semi-standard: 2		Semi-standard: 2J	
	Piping port thread type	(4) Part No.	Piping port thread type	(4) Part No.
	Rc	C2SF-2-A	Rc	C2SF-2J-A
	G	C2SF(Z)-A	G	C2SFF-2J-A
Semi-standard: 2J		Semi-standard: 2J		
Piping port thread type	(4) Part No.	Piping port thread type	(4) Part No.	
Rc	C2SF-2-A	Rc	C2SF-2J-A	
G	C2SFF-2J-A	G	C2SFF-2J-A	
NPT	C2SFN-2J(Z)-A	NPT	C2SFN-2J(Z)-A	
				

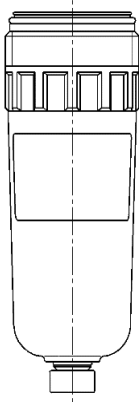
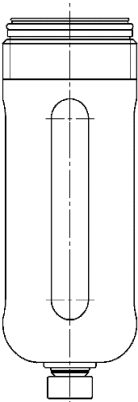
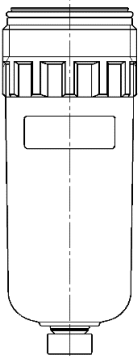
Option symbol	C ^{Note 1)}		C ^{Note 1)}	
Semi-standard symbol	—	6	C	6C
Appearance and part No.	Semi-standard: —		Semi-standard: C	
	Piping port thread type	(4) Part No.	Piping port thread type	(4) Part No.
	Rc	AD27-D	Rc	AD27-C-D
	G	AD27(-Z)-D	G	AD27-C(Z)-D
Semi-standard: 6		Semi-standard: 6C		
Piping port thread type	(4) Part No.	Piping port thread type	(4) Part No.	
Rc	AD27-6-A	Rc	AD27-6C-A	
G	AD27-6(Z)-A	G	AD27-6C(Z)-A	
NPT		NPT	AD27-6C(Z)-A	
				
Option symbol	C ^{Note 1)}			
Semi-standard symbol	2			
Appearance and part No.	Semi-standard: 2			
	Piping port thread type	(4) Part No.		
	Rc	AD27-2-A		
	G	AD27-2(Z)-A		
NPT				
				

Note 1) Minimum operating pressure is 0.1 MPa.

Note 2) Part No. (4) includes Bowl seal (3). Refer to the section [11. Disassembly Drawing] (P27).

Note 3) "Z" in Part No. (4) indicates semi-standard specifications. The pressure unit: psi. The temperature unit: °F.

Note 4) Refer to the section [4. How to Order] (P9) for option and semi-standard symbols.

6-2. Bowl assembly / auto drain for AFD30-D

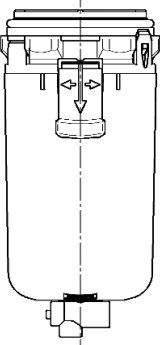
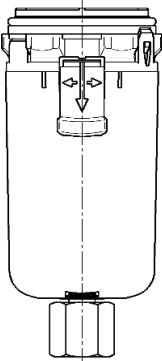
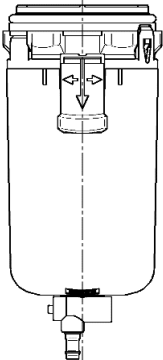
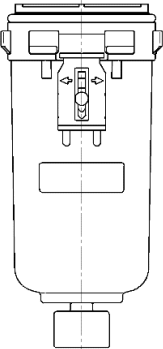
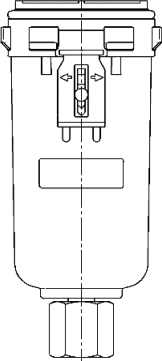
Option symbol	—		—																		
Semi-standard symbol	—	6	J	6J																	
Appearance and part No.	<p>Semi-standard: - (Standard)</p> <table border="1"> <tr> <td>Piping port thread type</td> <td>(4) Part No.</td> </tr> <tr> <td>Rc</td> <td rowspan="2">C3SF-D</td> </tr> <tr> <td>G</td> </tr> <tr> <td>NPT</td> <td>C3SF(-Z)-D</td> </tr> </table>		Piping port thread type	(4) Part No.	Rc	C3SF-D	G	NPT	C3SF(-Z)-D		<p>Semi-standard: J</p> <table border="1"> <tr> <td>Piping port thread type</td> <td>(4) Part No.</td> </tr> <tr> <td>Rc</td> <td>C3SF-J-D</td> </tr> <tr> <td>G</td> <td>C3SFF-J-D</td> </tr> <tr> <td>NPT</td> <td>C3SFN-J(Z)-D</td> </tr> </table>		Piping port thread type	(4) Part No.	Rc	C3SF-J-D	G	C3SFF-J-D	NPT	C3SFN-J(Z)-D	
	Piping port thread type	(4) Part No.																			
Rc	C3SF-D																				
G																					
NPT	C3SF(-Z)-D																				
Piping port thread type	(4) Part No.																				
Rc	C3SF-J-D																				
G	C3SFF-J-D																				
NPT	C3SFN-J(Z)-D																				
<p>Semi-standard: 6</p> <table border="1"> <tr> <td>Piping port thread type</td> <td>(4) Part No.</td> </tr> <tr> <td>Rc</td> <td rowspan="2">C3SF-6-A</td> </tr> <tr> <td>G</td> </tr> <tr> <td>NPT</td> <td>C3SF-6(Z)-A</td> </tr> </table>		Piping port thread type	(4) Part No.	Rc	C3SF-6-A	G	NPT	C3SF-6(Z)-A	<p>Semi-standard: 6J</p> <table border="1"> <tr> <td>Piping port thread type</td> <td>(4) Part No.</td> </tr> <tr> <td>Rc</td> <td>C3SF-6J-A</td> </tr> <tr> <td>G</td> <td>C3SFF-6J-A</td> </tr> <tr> <td>NPT</td> <td>C3SFN-6J(Z)-A</td> </tr> </table>		Piping port thread type	(4) Part No.	Rc	C3SF-6J-A	G	C3SFF-6J-A	NPT	C3SFN-6J(Z)-A			
Piping port thread type	(4) Part No.																				
Rc	C3SF-6-A																				
G																					
NPT	C3SF-6(Z)-A																				
Piping port thread type	(4) Part No.																				
Rc	C3SF-6J-A																				
G	C3SFF-6J-A																				
NPT	C3SFN-6J(Z)-A																				
Option symbol	—		—																		
Semi-standard symbol	W	6W																			
Appearance and part No.	<p>Semi-standard: W</p> <table border="1"> <tr> <td>Piping port thread type</td> <td>(4) Part No.</td> </tr> <tr> <td>Rc</td> <td rowspan="2">C3SF-W-D</td> </tr> <tr> <td>G</td> </tr> <tr> <td>NPT</td> <td>C3SF-W(Z)-D</td> </tr> </table>		Piping port thread type	(4) Part No.	Rc	C3SF-W-D	G	NPT	C3SF-W(Z)-D												
	Piping port thread type	(4) Part No.																			
Rc	C3SF-W-D																				
G																					
NPT	C3SF-W(Z)-D																				
<p>Semi-standard: 6W</p> <table border="1"> <tr> <td>Piping port thread type</td> <td>(4) Part No.</td> </tr> <tr> <td>Rc</td> <td rowspan="2">C3SF-6W-A</td> </tr> <tr> <td>G</td> </tr> <tr> <td>NPT</td> <td>C3SF-6W(Z)-A</td> </tr> </table>		Piping port thread type	(4) Part No.	Rc	C3SF-6W-A	G	NPT	C3SF-6W(Z)-A													
Piping port thread type	(4) Part No.																				
Rc	C3SF-6W-A																				
G																					
NPT	C3SF-6W(Z)-A																				
Option symbol	—		—																		
Semi-standard symbol	2		2J																		
Appearance and part No.	<p>Semi-standard: 2</p> <table border="1"> <tr> <td>Piping port thread type</td> <td>(4) Part No.</td> </tr> <tr> <td>Rc</td> <td rowspan="2">C3SF-2-A</td> </tr> <tr> <td>G</td> </tr> <tr> <td>NPT</td> <td>C3SF-2(Z)-A</td> </tr> </table>		Piping port thread type	(4) Part No.	Rc	C3SF-2-A	G	NPT	C3SF-2(Z)-A		<p>Semi-standard: 2J</p> <table border="1"> <tr> <td>Piping port thread type</td> <td>(4) Part No.</td> </tr> <tr> <td>Rc</td> <td>C3SF-2J-A</td> </tr> <tr> <td>G</td> <td>C3SFF-2J-A</td> </tr> <tr> <td>NPT</td> <td>C3SFN-2J(Z)-A</td> </tr> </table>		Piping port thread type	(4) Part No.	Rc	C3SF-2J-A	G	C3SFF-2J-A	NPT	C3SFN-2J(Z)-A	
	Piping port thread type	(4) Part No.																			
Rc	C3SF-2-A																				
G																					
NPT	C3SF-2(Z)-A																				
Piping port thread type	(4) Part No.																				
Rc	C3SF-2J-A																				
G	C3SFF-2J-A																				
NPT	C3SFN-2J(Z)-A																				
<table border="1"> <tr> <td>Piping port thread type</td> <td>(4) Part No.</td> </tr> <tr> <td>Rc</td> <td>C3SF-2-A</td> </tr> <tr> <td>G</td> <td>C3SF-2(Z)-A</td> </tr> </table>		Piping port thread type	(4) Part No.	Rc	C3SF-2-A	G	C3SF-2(Z)-A	<table border="1"> <tr> <td>Piping port thread type</td> <td>(4) Part No.</td> </tr> <tr> <td>Rc</td> <td>C3SF-2J-A</td> </tr> <tr> <td>G</td> <td>C3SFF-2J-A</td> </tr> <tr> <td>NPT</td> <td>C3SFN-2J(Z)-A</td> </tr> </table>		Piping port thread type	(4) Part No.	Rc	C3SF-2J-A	G	C3SFF-2J-A	NPT	C3SFN-2J(Z)-A				
Piping port thread type	(4) Part No.																				
Rc	C3SF-2-A																				
G	C3SF-2(Z)-A																				
Piping port thread type	(4) Part No.																				
Rc	C3SF-2J-A																				
G	C3SFF-2J-A																				
NPT	C3SFN-2J(Z)-A																				

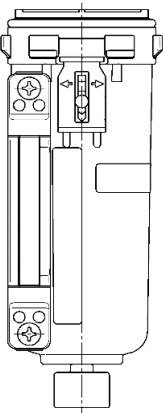
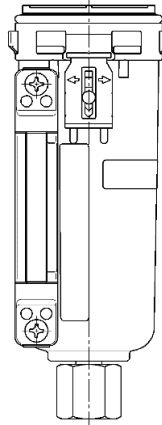
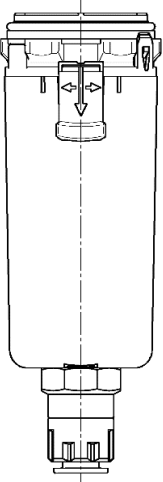
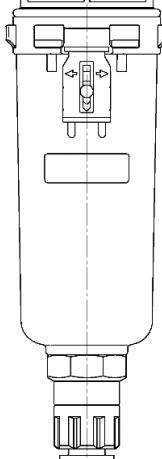
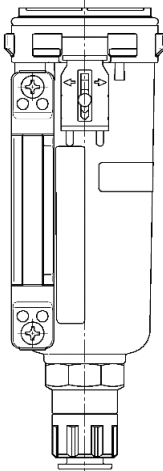
Option symbol	—		—																									
Semi-standard symbol	8		8J																									
Appearance and part No.	<p>Semi-standard: 8</p> <table border="1"> <tr> <td>Piping port thread type</td> <td>(4) Part No.</td> </tr> <tr> <td>Rc</td> <td>C3LF-8-A</td> </tr> <tr> <td>G</td> <td>C3LF-8(Z)-A</td> </tr> <tr> <td>NPT</td> <td>C3LF-8(Z)-A</td> </tr> </table> 		Piping port thread type	(4) Part No.	Rc	C3LF-8-A	G	C3LF-8(Z)-A	NPT	C3LF-8(Z)-A	<p>Semi-standard: 8J</p> <table border="1"> <tr> <td>Piping port thread type</td> <td>(4) Part No.</td> </tr> <tr> <td>Rc</td> <td>C3LF-8J-A</td> </tr> <tr> <td>G</td> <td>C3LFF-8J-A</td> </tr> <tr> <td>NPT</td> <td>C3LFN-8J(Z)-A</td> </tr> </table> 		Piping port thread type	(4) Part No.	Rc	C3LF-8J-A	G	C3LFF-8J-A	NPT	C3LFN-8J(Z)-A								
Piping port thread type	(4) Part No.																											
Rc	C3LF-8-A																											
G	C3LF-8(Z)-A																											
NPT	C3LF-8(Z)-A																											
Piping port thread type	(4) Part No.																											
Rc	C3LF-8J-A																											
G	C3LFF-8J-A																											
NPT	C3LFN-8J(Z)-A																											
Option symbol	C Note 1)		C Note 1)																									
Semi-standard symbol	—	6	2																									
Appearance and part No.	<p>Semi-standard: —</p> <table border="1"> <tr> <td>Piping port thread type</td> <td>(4) Part No.</td> </tr> <tr> <td>Rc</td> <td>AD37-D</td> </tr> <tr> <td>G</td> <td>AD37N(-Z)-D</td> </tr> <tr> <td>NPT</td> <td>AD37N(-Z)-D</td> </tr> </table>  <p>Semi-standard: 6</p> <table border="1"> <tr> <td>Piping port thread type</td> <td>(4) Part No.</td> </tr> <tr> <td>Rc</td> <td>AD37-6-A</td> </tr> <tr> <td>G</td> <td>AD37N-6(Z)-A</td> </tr> <tr> <td>NPT</td> <td>AD37N-6(Z)-A</td> </tr> </table>		Piping port thread type	(4) Part No.	Rc	AD37-D	G	AD37N(-Z)-D	NPT	AD37N(-Z)-D	Piping port thread type	(4) Part No.	Rc	AD37-6-A	G	AD37N-6(Z)-A	NPT	AD37N-6(Z)-A	<p>Semi-standard: 2</p> <table border="1"> <tr> <td>Piping port thread type</td> <td>(4) Part No.</td> </tr> <tr> <td>Rc</td> <td>AD37-2-A</td> </tr> <tr> <td>G</td> <td>AD37-2-A</td> </tr> <tr> <td>NPT</td> <td>AD37N-2(Z)-A</td> </tr> </table> 		Piping port thread type	(4) Part No.	Rc	AD37-2-A	G	AD37-2-A	NPT	AD37N-2(Z)-A
Piping port thread type	(4) Part No.																											
Rc	AD37-D																											
G	AD37N(-Z)-D																											
NPT	AD37N(-Z)-D																											
Piping port thread type	(4) Part No.																											
Rc	AD37-6-A																											
G	AD37N-6(Z)-A																											
NPT	AD37N-6(Z)-A																											
Piping port thread type	(4) Part No.																											
Rc	AD37-2-A																											
G	AD37-2-A																											
NPT	AD37N-2(Z)-A																											
Option symbol	C Note 1)																											
Semi-standard symbol	8																											
Appearance and part No.	<p>Semi-standard: 8</p> <table border="1"> <tr> <td>Piping port thread type</td> <td>(4) Part No.</td> </tr> <tr> <td>Rc</td> <td>AD37-8-A</td> </tr> <tr> <td>G</td> <td>AD37-8-A</td> </tr> <tr> <td>NPT</td> <td>AD37N-8(Z)-A</td> </tr> </table> 				Piping port thread type	(4) Part No.	Rc	AD37-8-A	G	AD37-8-A	NPT	AD37N-8(Z)-A																
Piping port thread type	(4) Part No.																											
Rc	AD37-8-A																											
G	AD37-8-A																											
NPT	AD37N-8(Z)-A																											
<p>Note 1) Minimum operating pressure is 0.15 MPa. Note 2) Part No. (4) includes Bowl seal (3). Refer to the section [11. Disassembly Drawing] (P27). Note 3) "Z" in Part No. (4) indicates semi-standard specifications. The pressure unit: psi. The temperature unit: °F. Note 4) Refer to the section [4. How to Order] (P9) for option and semi-standard symbols.</p>																												

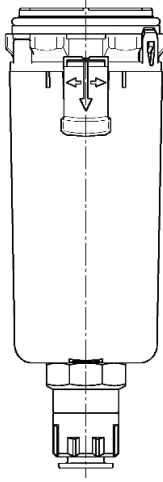
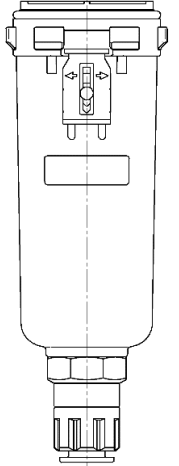
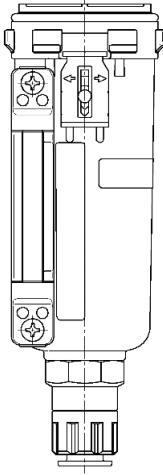
Option symbol	D Note 1)		D Note 1)																			
Semi-standard symbol	—	6	2																			
Appearance and part No.	Semi-standard: — <table border="1"> <tr> <td>Piping port thread type</td> <td>(4) Part No.</td> </tr> <tr> <td>Rc</td> <td>AD38-D</td> </tr> <tr> <td>G</td> <td>AD38N(-Z)-D</td> </tr> <tr> <td>NPT</td> <td>AD38N(-Z)-D</td> </tr> </table>		Piping port thread type	(4) Part No.	Rc	AD38-D	G	AD38N(-Z)-D	NPT	AD38N(-Z)-D		Semi-standard: 2 <table border="1"> <tr> <td>Piping port thread type</td> <td>(4) Part No.</td> </tr> <tr> <td>Rc</td> <td>AD38-2-A</td> </tr> <tr> <td>G</td> <td>AD38N-2(Z)-A</td> </tr> <tr> <td>NPT</td> <td>AD38N-2(Z)-A</td> </tr> </table>		Piping port thread type	(4) Part No.	Rc	AD38-2-A	G	AD38N-2(Z)-A	NPT	AD38N-2(Z)-A	
	Piping port thread type	(4) Part No.																				
Rc	AD38-D																					
G	AD38N(-Z)-D																					
NPT	AD38N(-Z)-D																					
Piping port thread type	(4) Part No.																					
Rc	AD38-2-A																					
G	AD38N-2(Z)-A																					
NPT	AD38N-2(Z)-A																					
Semi-standard: 6 <table border="1"> <tr> <td>Piping port thread type</td> <td>(4) Part No.</td> </tr> <tr> <td>Rc</td> <td>AD38-6-A</td> </tr> <tr> <td>G</td> <td>AD38N-6(Z)-A</td> </tr> <tr> <td>NPT</td> <td>AD38N-6(Z)-A</td> </tr> </table>		Piping port thread type	(4) Part No.	Rc	AD38-6-A	G	AD38N-6(Z)-A	NPT	AD38N-6(Z)-A													
Piping port thread type	(4) Part No.																					
Rc	AD38-6-A																					
G	AD38N-6(Z)-A																					
NPT	AD38N-6(Z)-A																					
Option symbol	D Note 1)																					
Semi-standard symbol	8																					
Appearance and part No.	Semi-standard: 8 <table border="1"> <tr> <td>Piping port thread type</td> <td>(4) Part No.</td> </tr> <tr> <td>Rc</td> <td>AD38-8-A</td> </tr> <tr> <td>G</td> <td>AD38N-8(Z)-A</td> </tr> <tr> <td>NPT</td> <td>AD38N-8(Z)-A</td> </tr> </table>		Piping port thread type	(4) Part No.	Rc	AD38-8-A	G	AD38N-8(Z)-A	NPT	AD38N-8(Z)-A												
Piping port thread type	(4) Part No.																					
Rc	AD38-8-A																					
G	AD38N-8(Z)-A																					
NPT	AD38N-8(Z)-A																					

Note 1) Minimum operating pressure is 0.1 MPa.

Note 2) Part No. (4) includes Bowl seal (3). Refer to the section [11. Disassembly Drawing] (P27).

Note 3) "Z" in Part No. (4) indicates semi-standard specifications. The pressure unit: psi. The temperature unit: °F.

Note 4) Refer to the section [4. How to Order] (P9) for option and semi-standard symbols.

6-3. Bowl assembly / auto drain for AFD40-D

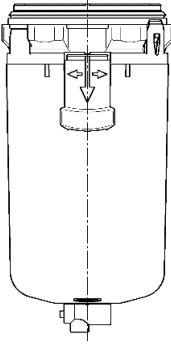
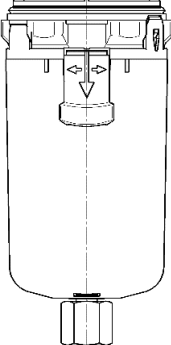
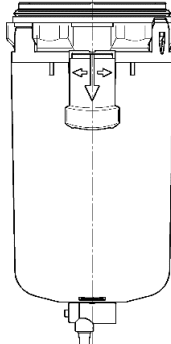
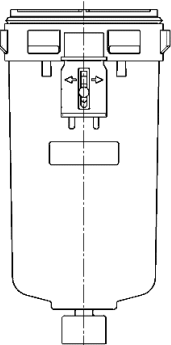
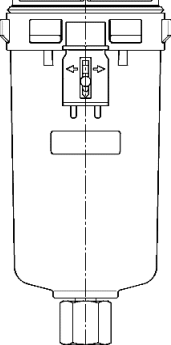
Option symbol	—		—	
Semi-standard symbol	—	6	J	6J
Appearance and part No.	Semi-standard: — (Standard)		Semi-standard: J	
	Piping port thread type	(4) Part No.	Piping port thread type	(4) Part No.
	Rc	C4SF-D	Rc	C4SF-J-D
	G		G	C4SFF-J-D
NPT	C4SF(-Z)-D	NPT	C4SFN-J(Z)-D	
Semi-standard: 6		Semi-standard: 6J		
Piping port thread type	(4) Part No.	Piping port thread type	(4) Part No.	
Rc	C4SF-6-A	Rc	C4SF-6J-A	
G		G	C4SFF-6J-A	
NPT	C4SF-6(Z)-A	NPT	C4SFN-6J(Z)-A	
Image				
Option symbol	—		—	
Semi-standard symbol	W	6W		
Appearance and part No.	Semi-standard: W			
	Piping port thread type	(4) Part No.		
	Rc	C4SF-W-D		
	G			
NPT	C4SF-W(Z)-D			
Semi-standard: 6W				
Piping port thread type	(4) Part No.			
Rc	C4SF-6W-A			
G				
NPT	C4SF-6W(Z)-A			
Image				
Option symbol	—		—	
Semi-standard symbol	2		2J	
Appearance and part No.	Semi-standard: 2		Semi-standard: 2J	
	Piping port thread type	(4) Part No.	Piping port thread type	(4) Part No.
	Rc	C4SF-2-A	Rc	C4SF-2J-A
	G		G	C4SFF-2J-A
NPT	C4SF-2(Z)-A	NPT	C4SFN-2J(Z)-A	
Image				

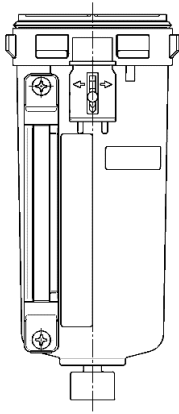
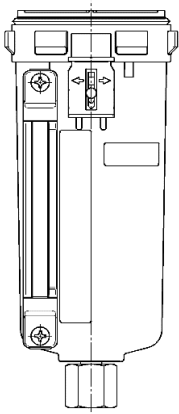
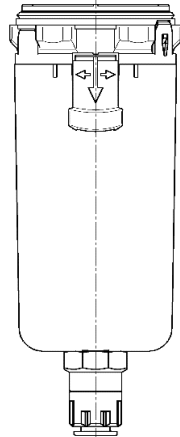
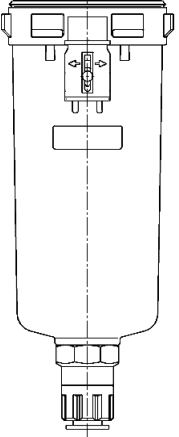
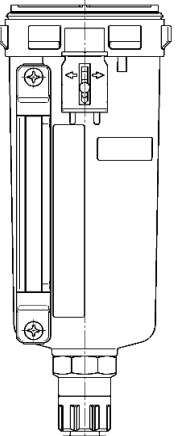
Option symbol	—		—																									
Semi-standard symbol	8		8J																									
Appearance and part No.	<p>Semi-standard: 8</p> <table border="1"> <tr> <td>Piping port thread type</td> <td>(4) Part No.</td> </tr> <tr> <td>Rc</td> <td>C4LF-8-A</td> </tr> <tr> <td>G</td> <td>C4LF-8(Z)-A</td> </tr> <tr> <td>NPT</td> <td>C4LF-8(Z)-A</td> </tr> </table> 		Piping port thread type	(4) Part No.	Rc	C4LF-8-A	G	C4LF-8(Z)-A	NPT	C4LF-8(Z)-A	<p>Semi-standard: 8J</p> <table border="1"> <tr> <td>Piping port thread type</td> <td>(4) Part No.</td> </tr> <tr> <td>Rc</td> <td>C4LF-8J-A</td> </tr> <tr> <td>G</td> <td>C4LFF-8J-A</td> </tr> <tr> <td>NPT</td> <td>C4LFN-8J(Z)-A</td> </tr> </table> 		Piping port thread type	(4) Part No.	Rc	C4LF-8J-A	G	C4LFF-8J-A	NPT	C4LFN-8J(Z)-A								
Piping port thread type	(4) Part No.																											
Rc	C4LF-8-A																											
G	C4LF-8(Z)-A																											
NPT	C4LF-8(Z)-A																											
Piping port thread type	(4) Part No.																											
Rc	C4LF-8J-A																											
G	C4LFF-8J-A																											
NPT	C4LFN-8J(Z)-A																											
Option symbol	C Note 1)		C Note 1)																									
Semi-standard symbol	—	6	2																									
Appearance and part No.	<p>Semi-standard: —</p> <table border="1"> <tr> <td>Piping port thread type</td> <td>(4) Part No.</td> </tr> <tr> <td>Rc</td> <td>AD47-D</td> </tr> <tr> <td>G</td> <td>AD47N(-Z)-D</td> </tr> <tr> <td>NPT</td> <td>AD47N(-Z)-D</td> </tr> </table> <p>Semi-standard: 6</p> <table border="1"> <tr> <td>Piping port thread type</td> <td>(4) Part No.</td> </tr> <tr> <td>Rc</td> <td>AD47-6-A</td> </tr> <tr> <td>G</td> <td>AD47N-6(Z)-A</td> </tr> <tr> <td>NPT</td> <td>AD47N-6(Z)-A</td> </tr> </table> 		Piping port thread type	(4) Part No.	Rc	AD47-D	G	AD47N(-Z)-D	NPT	AD47N(-Z)-D	Piping port thread type	(4) Part No.	Rc	AD47-6-A	G	AD47N-6(Z)-A	NPT	AD47N-6(Z)-A	<p>Semi-standard: 2</p> <table border="1"> <tr> <td>Piping port thread type</td> <td>(4) Part No.</td> </tr> <tr> <td>Rc</td> <td>AD47-2-A</td> </tr> <tr> <td>G</td> <td>AD47N-2(Z)-A</td> </tr> <tr> <td>NPT</td> <td>AD47N-2(Z)-A</td> </tr> </table> 		Piping port thread type	(4) Part No.	Rc	AD47-2-A	G	AD47N-2(Z)-A	NPT	AD47N-2(Z)-A
Piping port thread type	(4) Part No.																											
Rc	AD47-D																											
G	AD47N(-Z)-D																											
NPT	AD47N(-Z)-D																											
Piping port thread type	(4) Part No.																											
Rc	AD47-6-A																											
G	AD47N-6(Z)-A																											
NPT	AD47N-6(Z)-A																											
Piping port thread type	(4) Part No.																											
Rc	AD47-2-A																											
G	AD47N-2(Z)-A																											
NPT	AD47N-2(Z)-A																											
Option symbol	C Note 1)																											
Semi-standard symbol	8																											
Appearance and part No.	<p>Semi-standard: 8</p> <table border="1"> <tr> <td>Piping port thread type</td> <td>(4) Part No.</td> </tr> <tr> <td>Rc</td> <td>AD47-8-A</td> </tr> <tr> <td>G</td> <td>AD47N-8(Z)-A</td> </tr> <tr> <td>NPT</td> <td>AD47N-8(Z)-A</td> </tr> </table> 				Piping port thread type	(4) Part No.	Rc	AD47-8-A	G	AD47N-8(Z)-A	NPT	AD47N-8(Z)-A																
Piping port thread type	(4) Part No.																											
Rc	AD47-8-A																											
G	AD47N-8(Z)-A																											
NPT	AD47N-8(Z)-A																											
<p>Note 1) Minimum operating pressure is 0.15 MPa. Note 2) Part No. (4) includes Bowl seal (3). Refer to the section [11. Disassembly Drawing] (P27). Note 3) "Z" in Part No. (4) indicates semi-standard specifications. The pressure unit: psi. The temperature unit: °F. Note 4) Refer to the section [4. How to Order] (P9) for option and semi-standard symbols.</p>																												

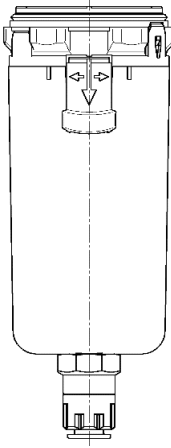
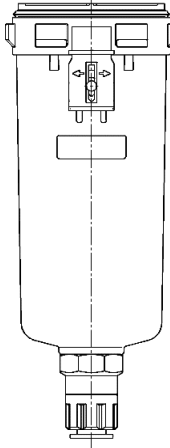
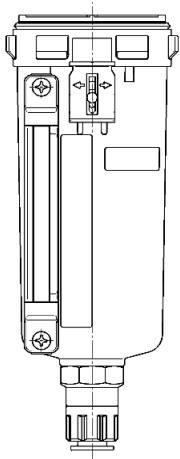
Option symbol	D ^{Note 1)}		D ^{Note 1)}															
Semi-standard symbol	—	6	2															
Appearance and part No.	Semi-standard: — <table border="1"> <tr> <td>Piping port thread type</td> <td>(4) Part No.</td> </tr> <tr> <td>Rc</td> <td>AD48-D</td> </tr> <tr> <td>G</td> <td>AD48N(-Z)-D</td> </tr> </table>		Piping port thread type	(4) Part No.	Rc	AD48-D	G	AD48N(-Z)-D		Semi-standard: 2 <table border="1"> <tr> <td>Piping port thread type</td> <td>(4) Part No.</td> </tr> <tr> <td>Rc</td> <td>AD48-2-A</td> </tr> <tr> <td>G</td> <td>AD48N-2(Z)-A</td> </tr> </table>		Piping port thread type	(4) Part No.	Rc	AD48-2-A	G	AD48N-2(Z)-A	
	Piping port thread type	(4) Part No.																
Rc	AD48-D																	
G	AD48N(-Z)-D																	
Piping port thread type	(4) Part No.																	
Rc	AD48-2-A																	
G	AD48N-2(Z)-A																	
Semi-standard: 6 <table border="1"> <tr> <td>Piping port thread type</td> <td>(4) Part No.</td> </tr> <tr> <td>Rc</td> <td>AD48-6-A</td> </tr> <tr> <td>G</td> <td>AD48N-6(Z)-A</td> </tr> </table>		Piping port thread type	(4) Part No.	Rc	AD48-6-A	G	AD48N-6(Z)-A											
Piping port thread type	(4) Part No.																	
Rc	AD48-6-A																	
G	AD48N-6(Z)-A																	
Option symbol	D ^{Note 1)}																	
Semi-standard symbol	8																	
Appearance and part No.	Semi-standard: 8 <table border="1"> <tr> <td>Piping port thread type</td> <td>(4) Part No.</td> </tr> <tr> <td>Rc</td> <td>AD48-8-A</td> </tr> <tr> <td>G</td> <td>AD48N-8(Z)-A</td> </tr> </table>		Piping port thread type	(4) Part No.	Rc	AD48-8-A	G	AD48N-8(Z)-A										
Piping port thread type	(4) Part No.																	
Rc	AD48-8-A																	
G	AD48N-8(Z)-A																	

Note 1) Minimum operating pressure is 0.1 MPa.

Note 2) Part No. (4) includes Bowl seal (3). Refer to the section [11. Disassembly Drawing] (P27).

Note 3) "Z" in Part No. (4) indicates semi-standard specifications. The pressure unit: psi. The temperature unit: °F.

Note 4) Refer to the section [4. How to Order] (P9) for option and semi-standard symbols.

7. Assembly of Optional Parts

Bracket

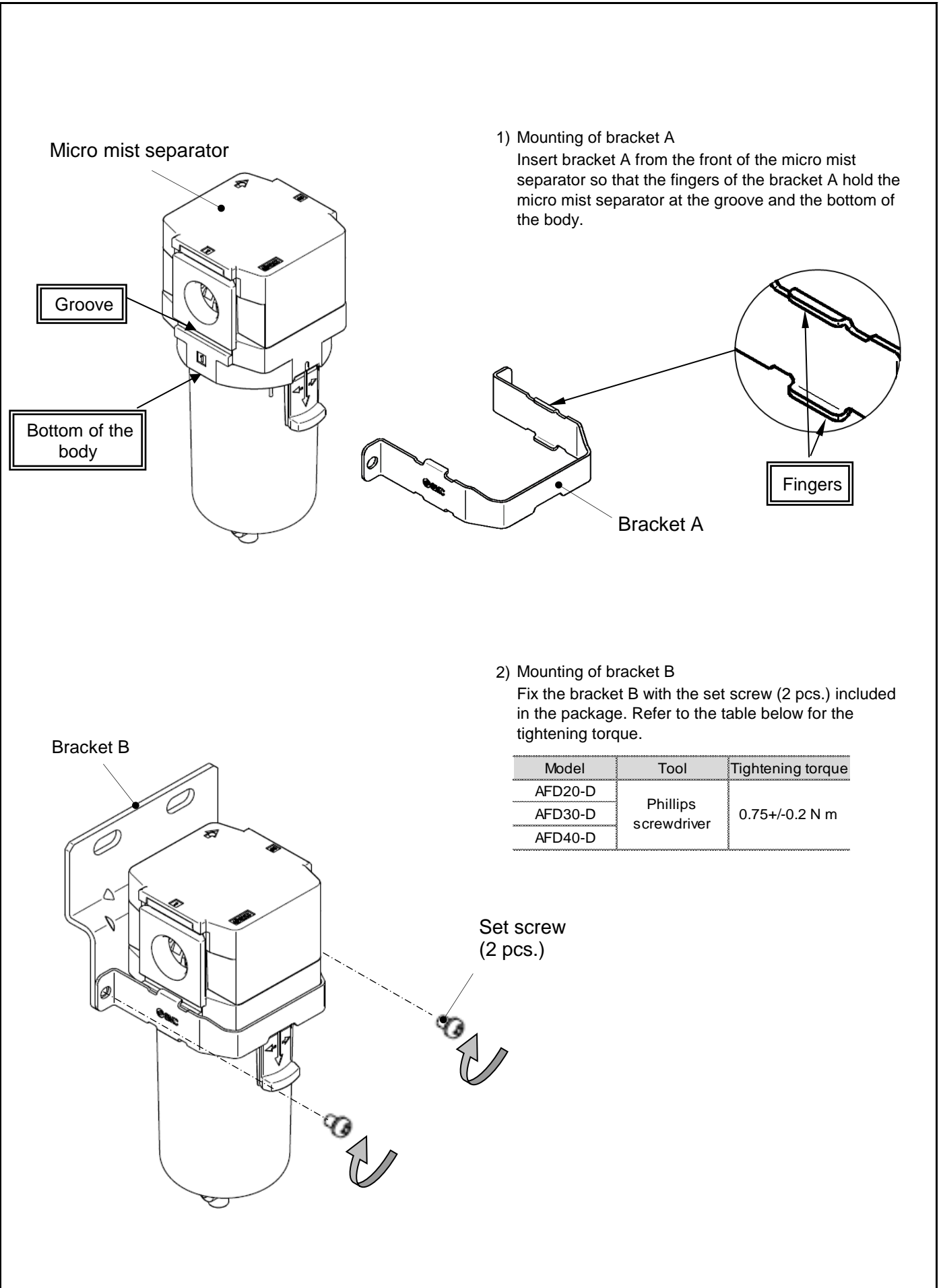

8. Operation and Adjustment

8-1. Discharge from the product with drain cock

- Pressurize the inside of the micro mist separator when discharging drain. Drain will not be discharged properly if not pressurized.
- Drain discharge mechanism is different depending on the bowl assembly. Check the bowl assembly and discharge the drain following the method below.
Rotation type: After discharging the drain, tighten the drain cock to the opposite direction by hand until the seal inside seals correctly. Use of a tool can damage the product.

AFD20-D: Drain cock (rotation type)
(Polycarbonate bowl/ Nylon bowl)

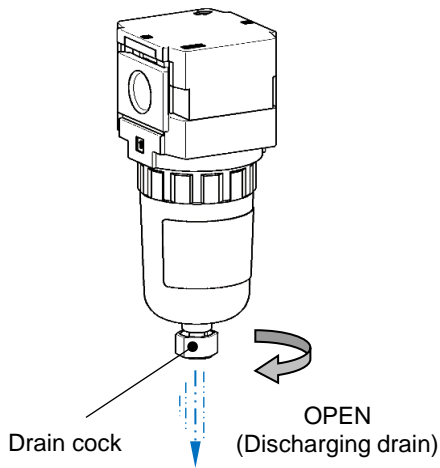

AFD30-D/ AFD40-D: Drain cock/with barb fitting (push type)
(Polycarbonate bowl / Nylon bowl)

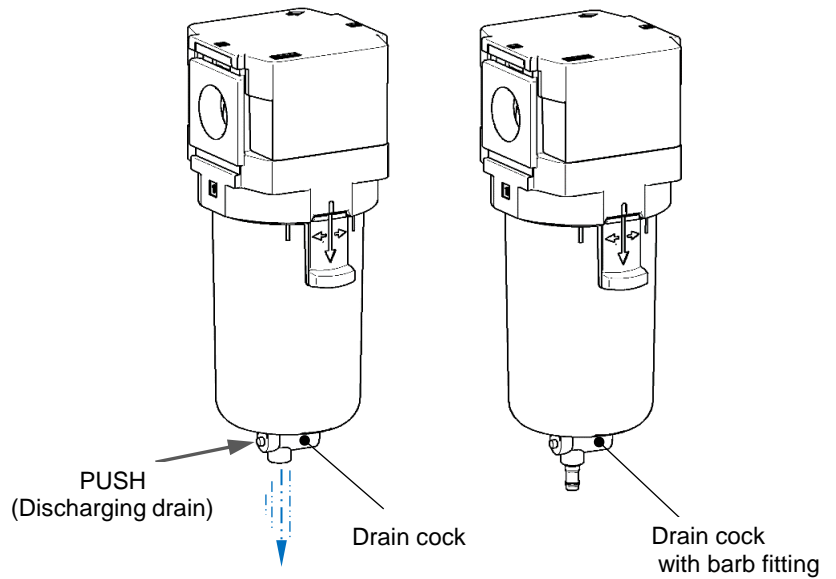

AFD20-D: Drain cock (push type)
(Metal bowl)

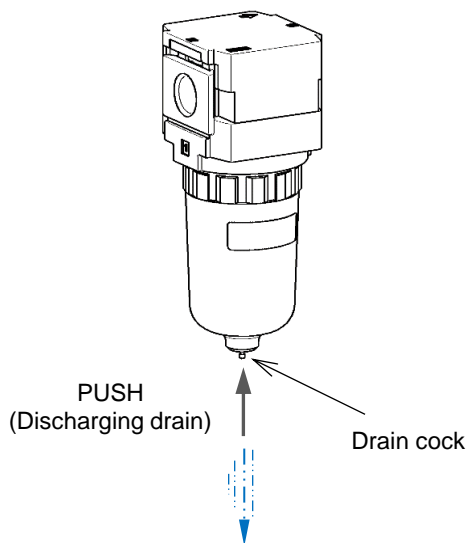

AFD30-D/ AFD40-D: Drain cock (rotation type)
(Metal bowl / Metal bowl with level gauge)

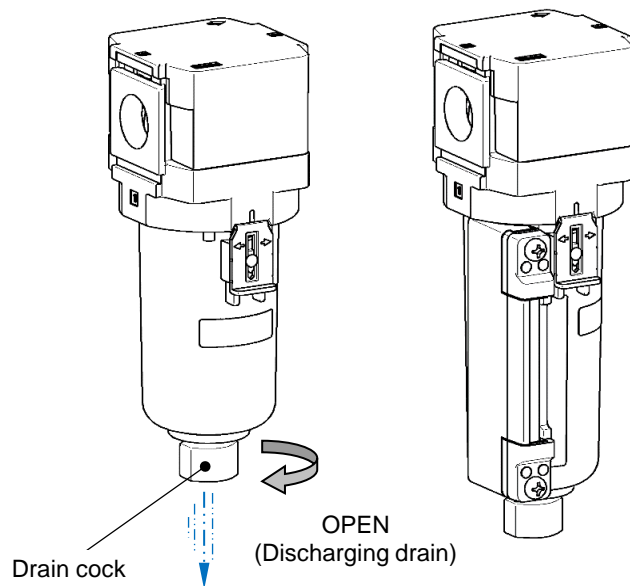

8-2. Manual drain discharge from the auto drain

- Pressurize the inside of the micro mist separator when discharging drain. Drain will not be discharged properly if not pressurized.
- To discharge the auto drain manually, follow the procedure below. After discharging the drain, rotate the cock to the opposite direction by hand to close the drain valve. Use of a tool can damage the product.

AFD20-D: Auto drain

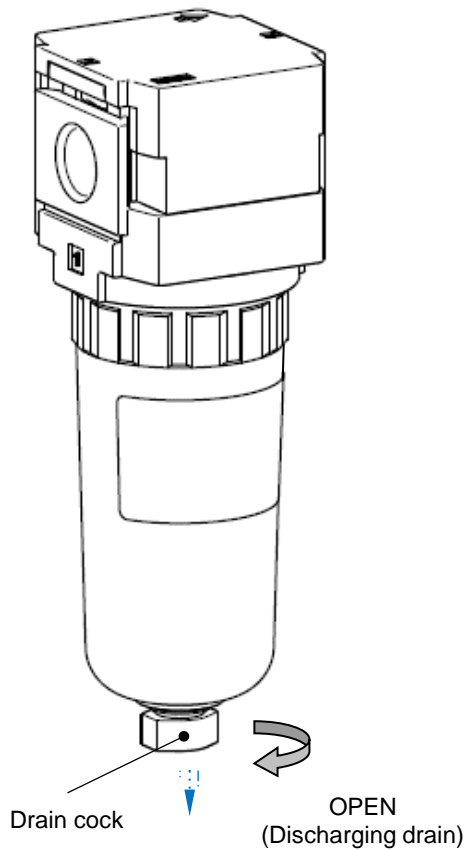

AFD30-D/ AFD40-D: Auto drain

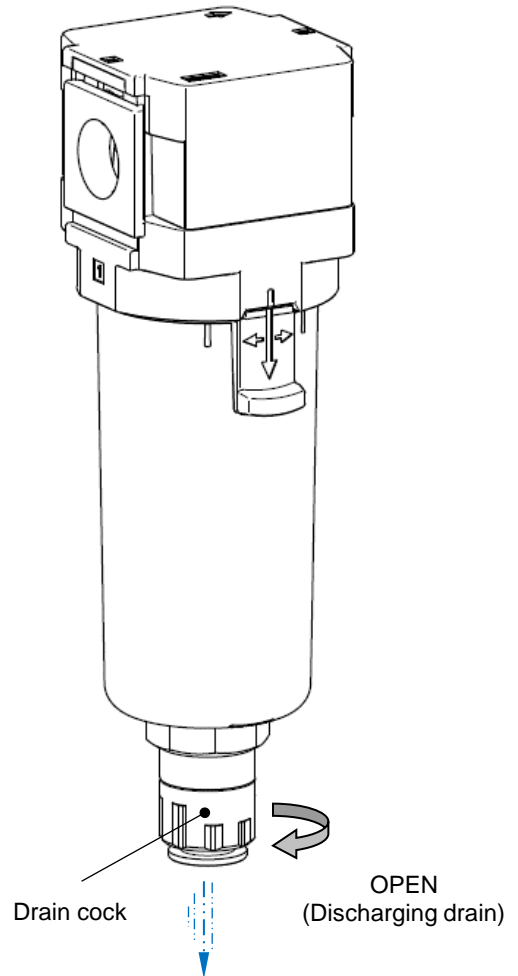

9. Trouble Shooting

Refer to the sections [8. Operation and Adjustment] (P20-21), [10. How to Replace the Components] (P23-26) and [11. Disassembly Drawing] (P27).

Trouble		Possible cause	Countermeasure	Page for reference
Category	Failure			
Flow rate	As pressure drop is large, fluid does not flow.	1. Clog of the element.	Replace the element assembly.	P23-26
	Air leakage from between the body and the bowl.	1. The bowl seal is damaged.	Replace the bowl seal. Grease up before replacing the bowl seal. <small>Note)</small>	P23-24
Air leakage	Air leakage from the bowl.	1. The bowl is damaged.	Replace the bowl assembly. (If the solvent is considered to be harmful, replacement to the metal bowl is recommended.)	P23-24
	Air leakage from the drain cock.	1. Foreign matter caught in the valve of the drain cock.	Open the drain cock for a few seconds for blowing.	P20-21
		2. Seating part of the drain cock is damaged.	Replace the bowl assembly.	P23-24
	Drain or air continues blowing out from the drain discharge of the float type auto drain.	1. Low supply pressure	Confirm the minimum operating pressure of the auto drain.	P8 P11-18
		2. The product is not mounted correctly.	Install the drain exhaust so that it will face vertically downward.	—
		3. Foreign matter is caught at the main valve of the auto drain.	Eliminate the dirt by manual discharge.	P21
		4. Main valve of the auto drain is broken.	Replace the bowl assembly.	P23-24
		5. Drain piping is long, or I.D. of the piping is small. (Back pressure is applied.)	Be sure to connect the appropriate piping for drain.	P6
		6. Drain discharging part and bowl seat are damaged.	Replace the bowl assembly.	P23-24
	Operability	Drain is not discharging when the drain cock opens.	1. Blockage of outlet of the drain cock due to solid foreign matter etc.	Replace the bowl assembly.
Too much drain comes from the piping of outlet side.		1. Drain level reaches the element assembly.	Open the drain cock for discharging and replace the element assembly.	P20-21 P23-26

Note) Fluorine grease is recommended.

10. How to Replace the Components



Warning

Before replacement, make sure that no pressure remains in the product.

After replacement, confirm that the product satisfies specific functions and no external leakage occurs before operating it.

10-1. Bowl Assembly Replacement

Applicable model	Work category	Procedure	Tool	Criteria
AFD20	Disassembly	1) Remove the bowl assembly from the product. If the bowl assembly is tightened too much to be removed, use a hook spanner until it can be loosened by hand.	Spanner specified for SMC Product No.: 1129129	—
	Work category	Procedure	Tool	Criteria
	Assembly	1) Screw the bowl assembly into the product. Tighten it referring to the specified torque.	-	Reference tightening torque: 2.1 N m

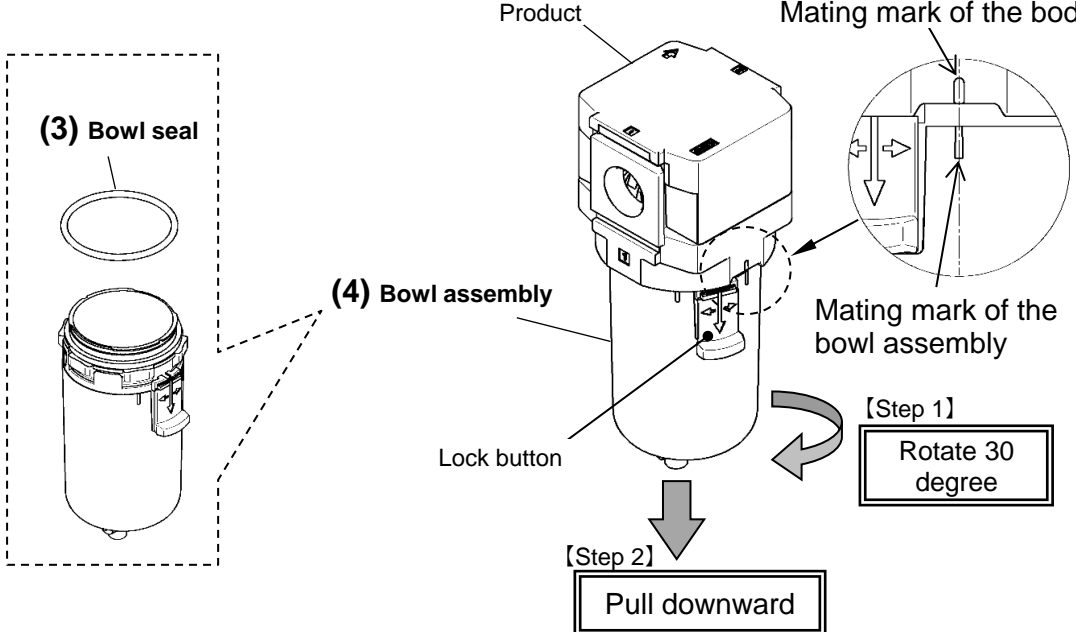
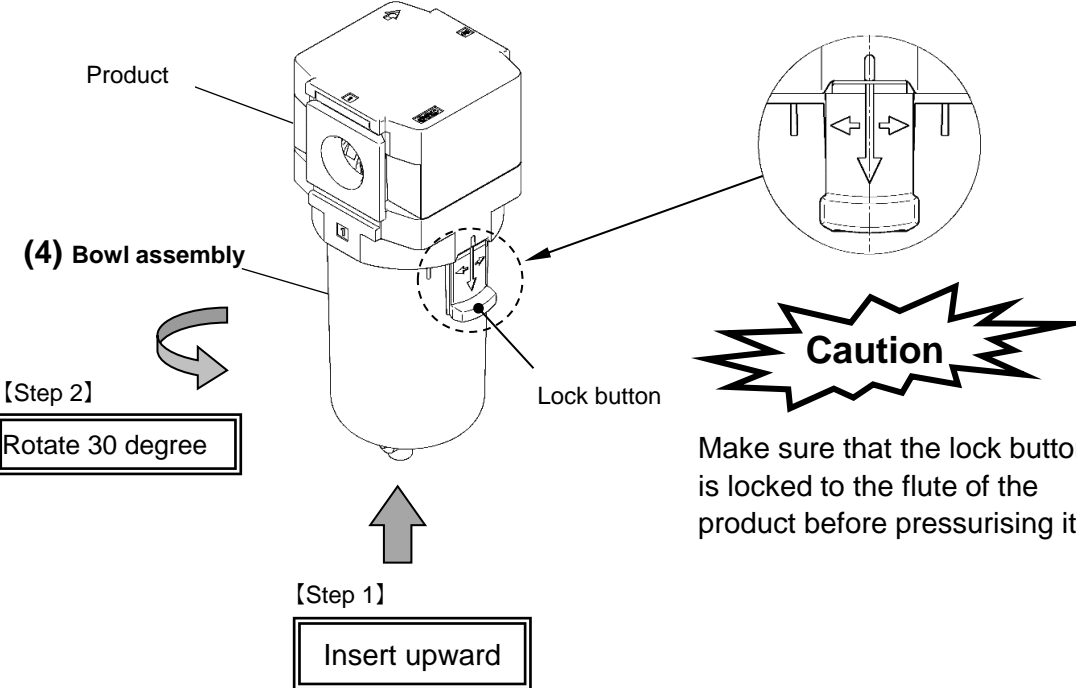
Applicable model	Work category	Procedure	Tool	Criteria
AFD30 AFD40	Disassembly	1) Remove the bowl assembly from the product. While the lock button is held down, rotate the bowl assembly by approx. 30 degrees so that the mating marks of the body and bowl assembly meet each other. Then remove the bowl assembly by pulling it downward.	-	-
<div style="text-align: right;">Align the mating marks</div>  <p>The diagram illustrates the disassembly process. On the left, a dashed box shows the components: (3) Bowl seal and (4) Bowl assembly. The main diagram shows the bowl assembly (4) being rotated 30 degrees (Step 1) to align the mating marks of the body and the bowl assembly. Then, the lock button is held down, and the bowl assembly is pulled downward (Step 2) to separate it from the product.</p>				
Work category	Procedure	Tool	Criteria	
Assembly	1) Mount the bowl assembly to the product and rotate the bowl assembly until the lock button is locked in position as shown in the figure below.	-	-	
 <p>The diagram illustrates the assembly process. Step 1 is to insert the bowl assembly (4) upward into the product. Step 2 is to rotate the bowl assembly 30 degrees until the lock button is locked in position. A caution note states: "Caution: Make sure that the lock button is locked to the flute of the product before pressurising it."</p>				

10-2. Element Replacement

Applicable model	Work category	Procedure	Tool	Criteria
AFD20	Disassembly	<p>1) Remove the bowl assembly referring to the section [10-1. Bowl Assembly Replacement] (P23). After that, remove the element assembly by rotating it counterclockwise using a spanner.</p>	Spanner nominal size: 7	-
Work category	Procedure	Tool	Criteria	
Assembly	<p>1) Mount the element assembly by rotating it clockwise using a spanner. Tighten the element assembly referring to the torque specified on the right. Mount the the bowl assembly referring to the section [10-1. Bowl Assembly Replacement] (P23).</p>	Spanner nominal size: 7	Tightening torque: 0.49+/-0.05 N m	

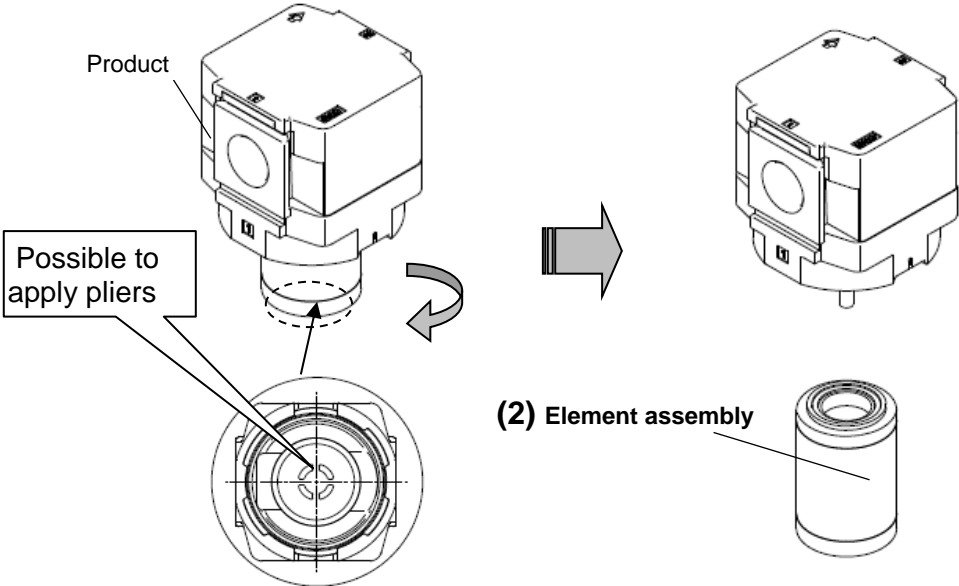
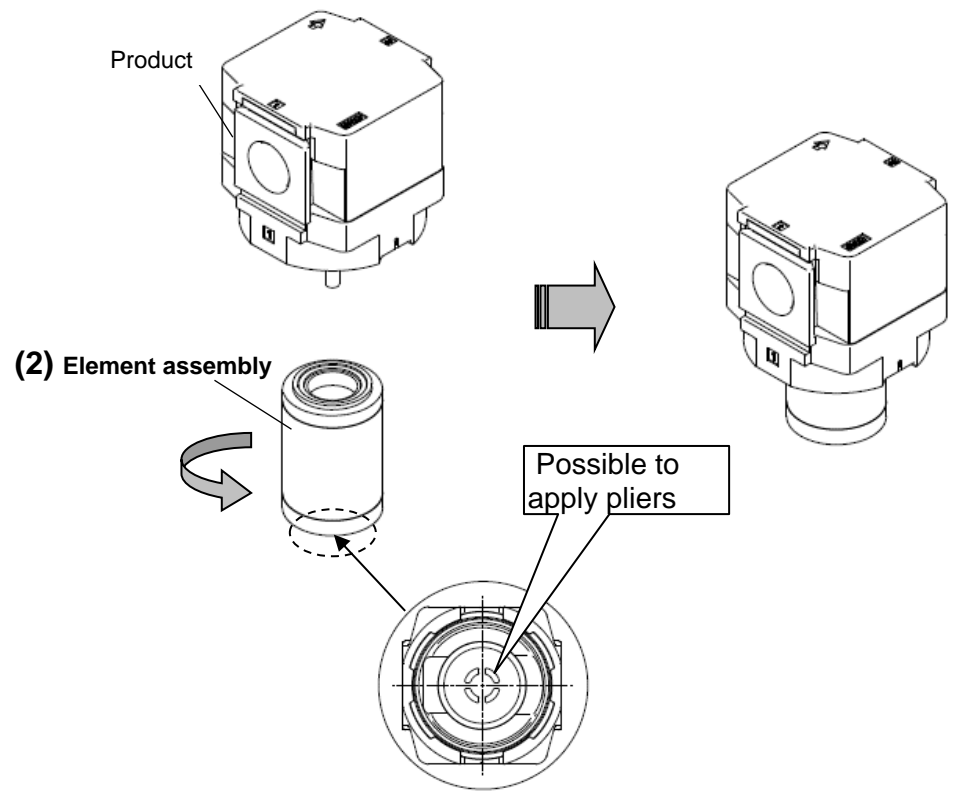
Applicable model	Work category	Procedure	Tool	Criteria
AFD30 AFD40	Disassembly	<p>1) Remove the bowl assembly referring to the section [10-1. Bowl Assembly Replacement] (P24). After that, remove the element assembly by rotating it counterclockwise using round nose pliers.</p> 	Round nose pliers	—
	Work category	Procedure	Tool	Criteria
	Assembly	<p>1) Mount the element assembly by rotating it clockwise using round nose pliers. Tighten the element assembly referring to the torque specified on the right. Mount the bowl assembly referring to the section [10-1. Bowl Assembly Replacement] (P24).</p> 	Round nose pliers	Tightening torque: AFD30-D: 1.47+/-0.2 N m AFD40-D: 1.96+/-0.2 N m

11. Disassembly Drawing

AFD20-D

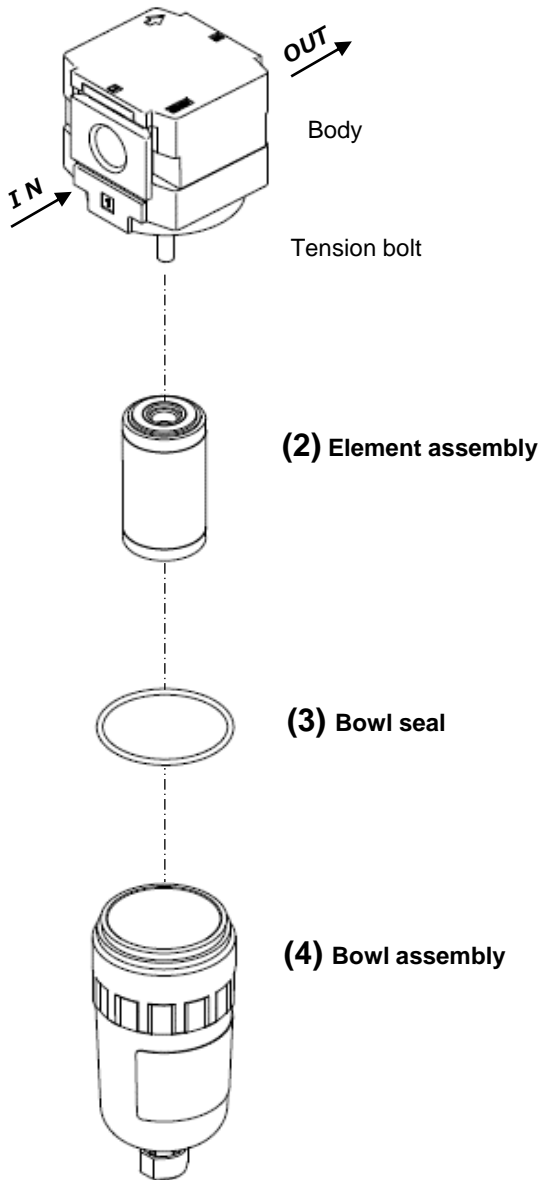

AFD30-D, AFD40-D

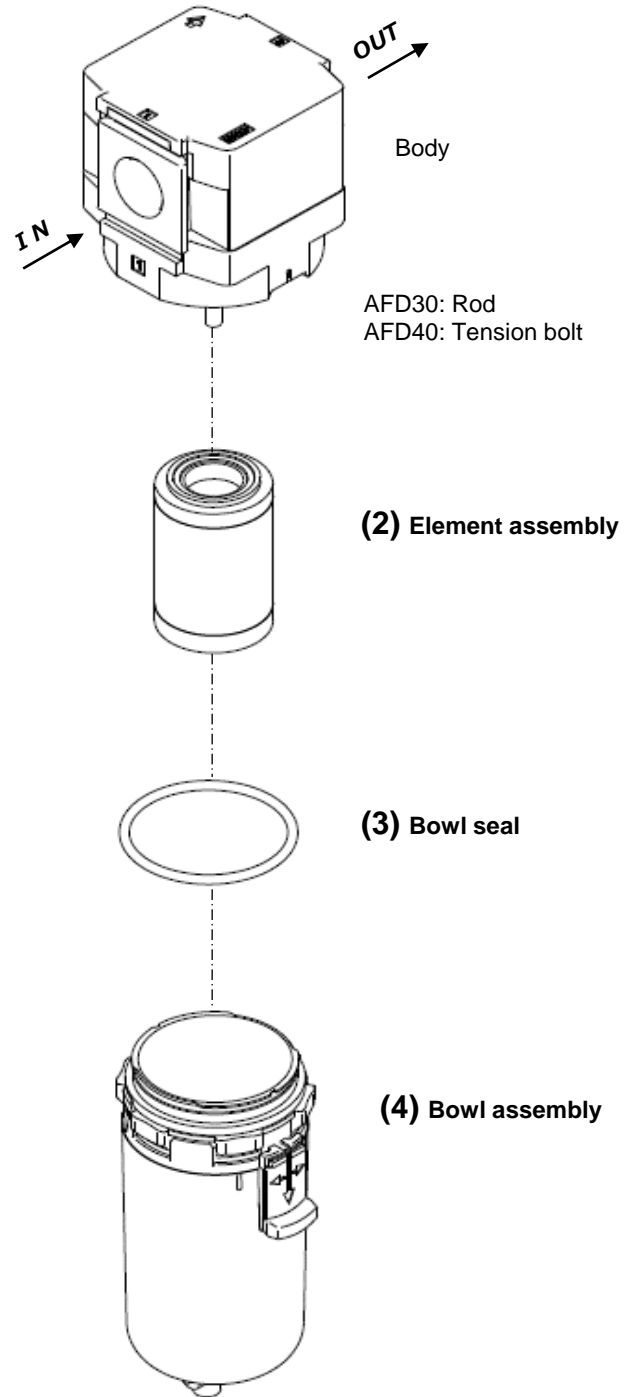

12. Dimensions

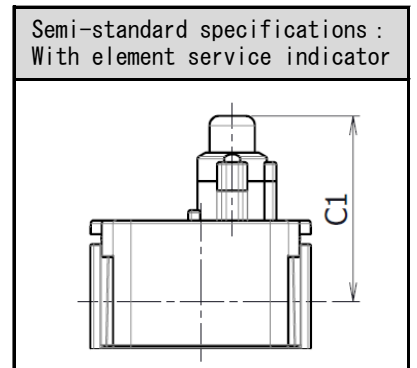
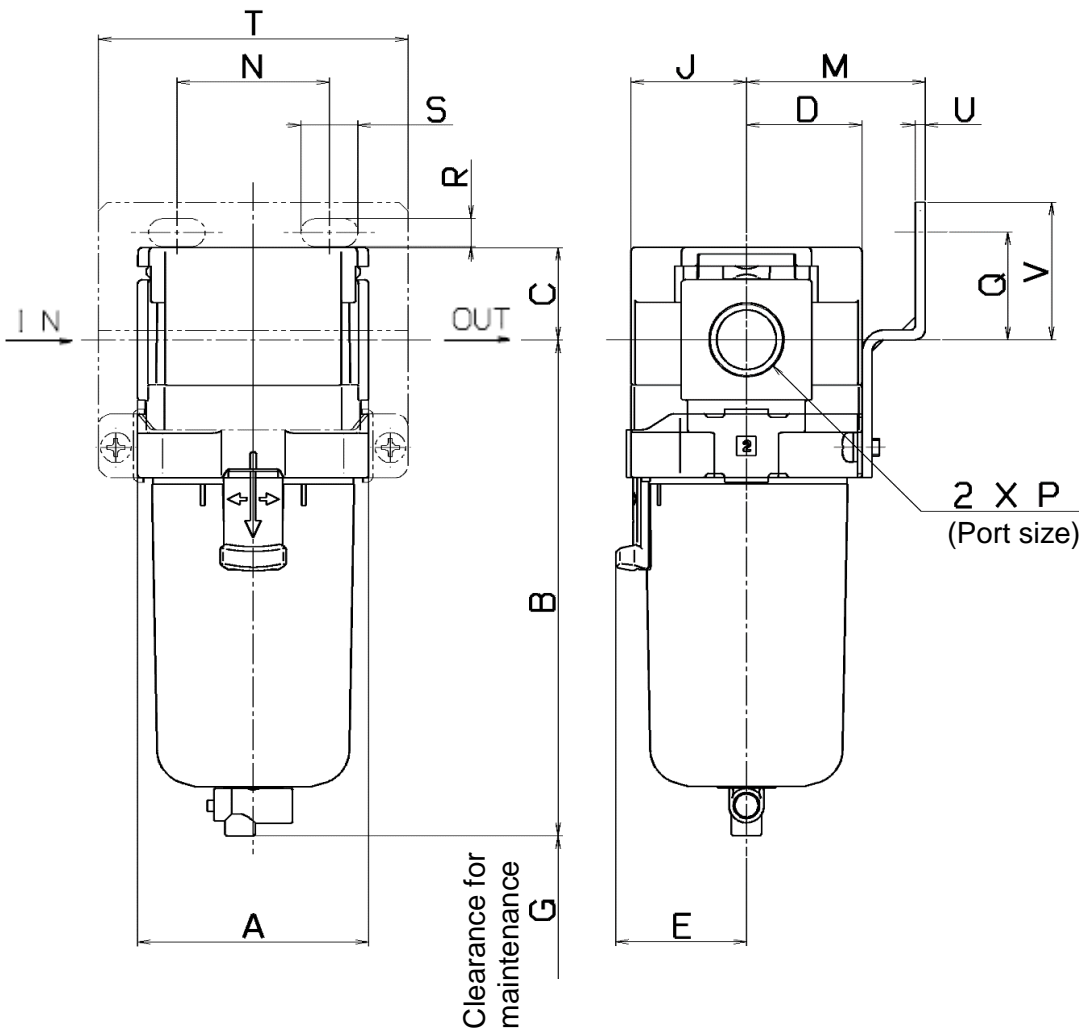

Model	Standard specifications							Optional specifications									
	P	A	B	C	D	E	G	J	M	N	Q	R	S	T	U	V	B
AFD20-D	1/8, 1/4	40	87.6	17.5	21	-	45	21	30	27	22	5.4	8.4	60	2.3	28	104.9
AFD30-D	1/4, 3/8	53	115.4	21.5	26.5	30	50	26.5	41	35	25	6.5	13	71	2.3	32	157.1
AFD40-D	1/4, 3/8, 1/2	70	147.1	25.5	35.5	38.4	75	35.5	50	52	30	8.5	12.5	88	2.3	39	186.9
AFD40-06-D	3/4	75	149.1	27	35.5	38.4	75	35.5	50	52	34	8.5	12.5	88	2.3	43	188.9

Model	Semi-standard specifications							
	PC/PA bowl		Metal bowl		Metal bowl with level gauge		With element service indicator	
	With barb fitting	With drain guide	With drain cock	With drain guide	With drain cock	With drain guide		
B	B	B	B	B	B	A	C1	
AFD20-D	-	91.4	87.4	93.9	-	-	40	50.6
AFD30-D	123.9	122.2	117.8	122.3	137.8	142.3	53	54.3
AFD40-D	155.6	153.9	149.5	154	169.5	174	70	58.3
AFD40-06-D	157.6	155.9	151.5	156	171.5	176	-	-

Revision history

A	Size 40-06 added. Addition to the Waning of the Piping.	Nov. 2020.
B	Element service indicator specification added.	Sep. 2021.

SMC Corporation

4-14-1, Sotokanda, Chiyoda-ku, Tokyo 101-0021 JAPAN
Tel: + 81 3 5207 8249 Fax: +81 3 5298 5362
URL <https://www.smcworld.com>